



# Air-to-water reversible heat pumps and water chillers

All-in-one,  
ready to use design  
Designed for **ultra-fast**  
installation



Cooling capacity: 5 to 17 kW  
Heating capacity: 6 to 19 kW

AQUALIS 2



Cooling or heating



Hydraulic module



## USE

Aqualis 2 air-to-water reversible heat pumps and chillers are perfect for the air conditioning and heating needs in homes (houses, flats) and businesses (offices, banks, hotels).

They are certified by Eurovent and NF PAC, deliver comfort, quality and savings.

They may be combined with a wide selection of indoor comfort units.

Reversible models may be connected in parallel to an existing fuel oil or gas powered heating system.

**When used for heating only**, they can supply a radiant floor or low-temperature radiators.

**When used for heating and cooling**, they may be combined with:

- A conventional system of fan coil units (e.g. Major Line, cassettes).
- A radiant floor heating and cooling system.
- A mixed system comprising, for example a radiant floor heating and cooling system downstairs and fan coil units upstairs.

## RANGE

The Aqualis 2 series consists of a broad range of coolers and heat pumps that deliver the right comfort levels for your interior. Two versions are available:

– Cooling only and air-to-water reversible heat pumps.

Each unit is designed to run at below-freezing temperatures.

■ Cooling mode (down to  $-10^{\circ}\text{C}$ ): the fan speed is adjusted to the outdoor temperature.

■ Heating mode (down to  $-15^{\circ}\text{C}$ ): a separate boiler or electric loop heater is necessary in areas where the temperature falls below  $-15^{\circ}\text{C}$ .

■ Boiler switchover (to balancing point): the temperature below

which the equipment is no longer sufficient to meet the heating needs (alternating or simultaneous operation with a boiler).

Compressor and refrigeration circuit.

10 models:

■ AQUALIS 2 (COOLING ONLY):

35T . 50T . 65T . 75T.

■ AQUALIS 2 (REVERSIBLE):

20H . 20HT . 28H . 28HT . 35H . 35HT . 50H . 50HT . 65HT . 75HT

## DESCRIPTION

**Standard equipment:**

- SCROLL compressor.
- Stainless steel brazed plate water-cooled heat exchanger.
- Copper tube coil with aluminium fins.
- Propeller fan (1 or 2 depending on model).

Speed adjusted to outdoor temperature levels for all-season operation in both heating and cooling mode.

**Control:**

Microprocessor control unit with two-wire MicroCONNECT remote control.

Water circuit with built-in accelerator pump and expansion vessel.

UV-stabilised recyclable plastic casing.

■ Meets the the following directives:

(EMC) 2004/108/EC

97/23/EC (pressure equipment)

→ category 1 (sizes 20 - 28 - 35 - 50)

→ category 2 (sizes 65 - 75)

NFC15-100



### QUICK SELECTION TABLE

AQUALIS 2 - COOLING ONLY								35T	50T	65T	75T
AQUALIS 2 - REVERSIBLE		20H	28H	35H	50H	20HT	28HT	35HT	50HT	65HT	75HT
Cooling capacity (cooling only)	kW	4.78	6.52	8.21	11.65	4.8	6.48	8.12	11.54	14.71	16.41
Power input	kW	2.16	2.7	3.69	4.16	2.16	2.68	3.43	4.61	5	6.47
EER		2.21	2.42	2.22	2.8	2.22	2.42	2.36	2.5	2.94	2.54
Heating capacity (reversible)	kW	6.22	8.11	10.39	13.17	6.22	8.4	10.21	13.79	17.22	19.41
Power input	kW	1.77	2.25	2.97	3.20	1.6	2.0	2.72	3.5	4.29	4.85
COP		3.51	3.6	3.5	4.11	3.89	4.2	3.75	3.95	4.01	4.01
Power supply voltage		230V - 1ph - 50 Hz + Earth + N					400V - 3ph - 50 Hz + Earth + N				
Sound level	dB(A)	66	69	73	73	66	69	73	73	75	75

Heating and sound data certified NFPAC

### COMPONENTS

#### Hermetic compressor

- Rotary scroll compressor on/off
- Built-in electric motor cooled by suction gases.
- Motor protected by winding sensor.

#### Water-to-refrigerant heat exchangers

- Brazed plates.
- Intermediate and end plates made of AISI 316 stainless steel.
- High-performance, optimised plate patterns.
- Thermal insulation.

#### Air-cooled heat exchanger

- Bent coil made of copper tubes and aluminium fins.

#### Standard accessories

- Reversing valve (reversible models).
- Anti-slugging accumulator.
- Liquid tank (reversible models).
- Expansion valve.
- Dryer.

#### Electrical panel

- Box built to EN 60335 standards.
- Power circuit protection.
- Compressor motor contactor.
- Main earth connection.
- Electronic control unit with microprocessor:

■ Chilled or hot water temperature controller (reversible heat pumps).

■ Water law based on the outdoor temperature.

■ Self-adjusting control during compressor short cycles, increase in stage differential.

■ Boiler-heat pump switchover/simultaneous operation mode (reversible models): managed automatically by the control system via a setting that can be adjusted based on the outdoor temperature.

- Monitoring of operating settings.
- Temperatures displayed on terminal. Air settings in terminal unit and RFHC mode
- Unit control
- Two-wire remote-control terminal. ON/OFF input control (two inputs, automatic/load shedding, heating - cooling/absence).
- 5-minute short-cycle protection.

#### Safety and control devices

- High-pressure safety switches.
- Two frost sensors (exchanger water outlet and exchanger refrigerant outlet).
- Chilled and hot water sensors (on exchanger water inlet).

#### Built-in hydraulic module

- 4-bar safety valve.
- Expansion vessel.
- Manual air bleed valve.
- Multi-speed accelerator pump.
- Differential water pressure switch.

#### Option (for installation on site)

- Insulated flexible connections.
- Anti-vibration mounts.
- Screen filter kit with shut-off valves.
- Charging kit.
- Crankcase heater kit
- Loop heater.



# Air-to-water reversible heat pumps and water chillers

## HYDRAULIC MODULE PRINCIPLE DIAGRAM

### Cooling only model

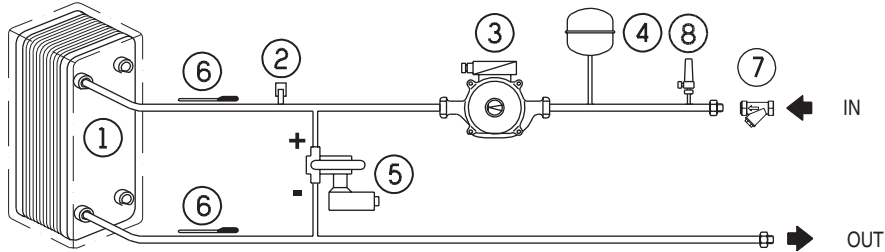

### Reversible model

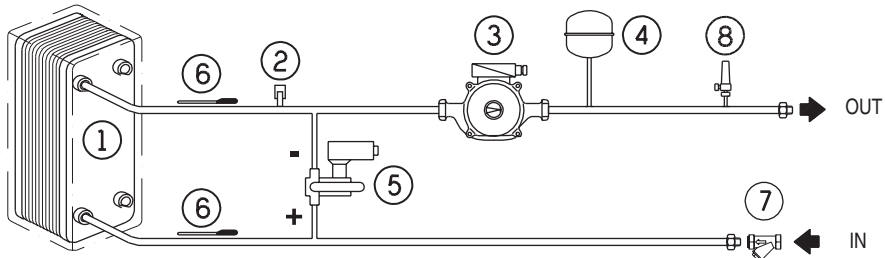

- ① Brazed-plate heat exchanger
- ② Manual air bleed valve
- ③ Accelerator pump
- ④ Expansion vessel
- ⑤ Differential pressure switch
- ⑥ Temperature sensors
- ⑦ Screen filter
- ⑧ 4-bar safety valve

## OPERATING LIMITS

### Chilled water production

Minimum water return temperature during operation: +40°C

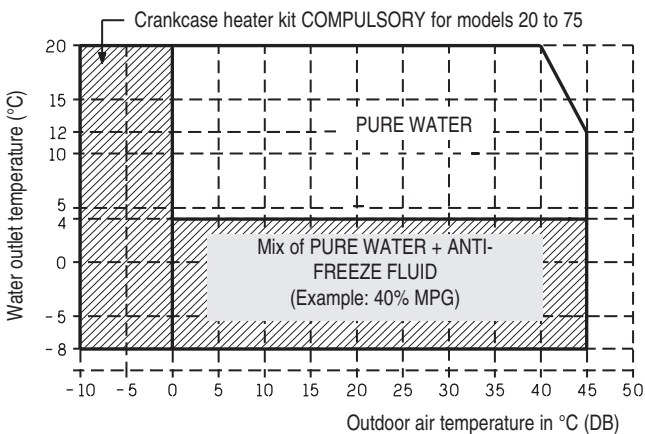

### Hot water production

Maximum water return temperature during operation:  
Anti-freeze fluid: +5°C / Pure water: +10°C  
Maximum water inlet temperature: +70°C

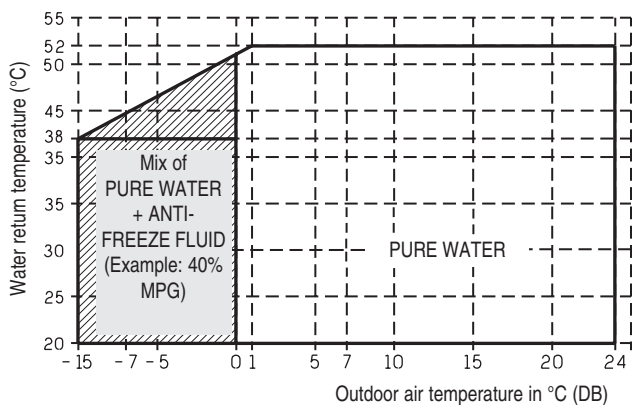

### Required water flow rates

AQUALIS 2	20	28	35	50	65	75
Minimum flow rate (m³/h)	0.7	0.9	1.1	1.5	2.0	2.45
Nominal flow, cooling mode (m³/h)	0.9	1.2	1.5	2.0	2.7	3.0
Nominal flow, heating mode (m³/h)	1	1.4	1.7	2.3	2.8	3.5



# Air-to-water reversible heat pumps and water chillers

## AQUALIS 2

### HEATING CAPACITIES

#### Aqualis 2 - reversible

AQUALIS 2	Ext Air Temp °C	Hot water outlet temp. (°C)																				
		25			30			35			40			45			50			55		
		Pf kW	Pa kW	Pc kW	Pf kW	Pa kW	Pc kW	Pf kW	Pa kW	Pc kW	Pf kW	Pa kW	Pc kW	Pf kW	Pa kW	Pc kW	Pf kW	Pa kW	Pc kW	Pf kW	Pa kW	Pc kW
20H	-15	1.9	1.4	3.3	1.8	1.5	3.3	1.4	1.7	3.1	1.1	1.9	3.0									
	-10	2.4	1.3	3.7	2.2	1.5	3.7	2.0	1.7	3.7	1.8	1.9	3.7	1.5	2.1	3.6						
	-5	3.1	1.3	4.4	2.8	1.5	4.3	2.6	1.7	4.3	2.3	1.9	4.2	2.1	2.1	4.2	1.6	2.4	4.0			
	0	3.7	1.3	5.0	3.4	1.5	4.9	3.3	1.7	4.9	2.9	1.9	4.8	2.6	2.1	4.7	2.1	2.4	4.5	1.8	2.5	4.3
	5	4.6	1.3	5.9	4.3	1.5	5.8	4.1	1.7	5.7	3.7	1.9	5.6	3.5	2.1	5.6	3.2	2.3	5.5	2.7	2.5	5.2
	10	5.4	1.3	6.7	5.1	1.5	6.6	4.9	1.6	6.5	4.6	1.8	6.4	4.1	2.1	6.2	3.8	2.3	6.1	3.4	2.5	5.9
	15	6.3	1.3	7.6	5.9	1.5	7.4	5.7	1.6	7.3	5.3	1.8	7.1	5.0	2.0	7.0	4.5	2.3	6.8	4.1	2.5	6.6
20	7.1	1.3	8.4	6.9	1.4	8.3	6.5	1.6	8.1	6.1	1.8	7.9	5.7	2.0	7.7	5.2	2.3	7.5	4.8	2.5	7.3	
20HT	-15	2.0	1.3	3.3	1.9	1.4	3.3	1.5	1.6	3.1	1.2	1.8	3.0									
	-10	2.5	1.2	3.7	2.3	1.4	3.7	2.1	1.6	3.7	1.9	1.8	3.7	1.6	2.0	3.6						
	-5	3.2	1.2	4.4	2.9	1.4	4.3	2.7	1.6	4.3	2.4	1.8	4.2	2.2	2.0	4.2	1.7	2.3	4.0			
	0	3.8	1.2	5.0	3.5	1.4	4.9	3.3	1.6	4.9	3.0	1.8	4.8	2.7	2.0	4.7	2.2	2.3	4.5	1.9	2.4	4.3
	5	4.7	1.2	5.9	4.4	1.4	5.8	4.1	1.6	5.7	3.8	1.8	5.6	3.6	2.0	5.6	3.3	2.2	5.5	2.8	2.4	5.2
	10	5.5	1.2	6.7	5.2	1.4	6.6	4.9	1.6	6.5	4.7	1.7	6.4	4.2	2.0	6.2	3.9	2.2	6.1	3.5	2.4	5.9
	15	6.4	1.2	7.6	6.0	1.4	7.4	5.8	1.5	7.3	5.4	1.7	7.1	5.1	1.9	7.0	4.6	2.2	6.8	4.2	2.4	6.6
20	7.2	1.2	8.4	7.0	1.3	8.3	6.6	1.5	8.1	6.2	1.7	7.9	5.8	1.9	7.7	5.3	2.2	7.5	4.9	2.4	7.3	
28H	-15	2.6	1.7	4.3	2.3	2.0	4.3	2.2	2.2	4.3	1.7	2.5	4.1									
	-10	3.3	1.7	5.0	3.0	1.9	4.9	2.8	2.1	4.9	2.4	2.4	4.8	1.6	2.9	4.5						
	-5	4.0	1.7	5.7	3.7	1.9	5.6	3.5	2.1	5.6	3.3	2.4	5.6	2.6	2.9	5.5	2.2	3.0	5.2			
	0	4.8	1.7	6.5	4.2	1.9	6.1	4.2	2.1	6.3	3.9	2.3	6.2	3.4	2.7	6.1	3.3	3.0	6.3	2.9	3.2	6.1
	5	6.5	1.7	8.1	6.1	1.9	8.0	5.8	2.1	7.9	5.5	2.3	7.8	5.2	2.6	7.8	4.7	2.8	7.5	4.2	3.1	7.3
	10	7.6	1.7	9.2	7.1	1.9	9.0	6.8	2.1	8.9	6.4	2.3	8.7	6.1	2.5	8.6	5.5	2.8	8.3	4.8	3.1	7.9
	15	8.7	1.6	10.3	8.2	1.9	10.1	7.8	2.1	9.9	7.5	2.2	9.7	7.1	2.5	9.6	6.6	2.8	9.4	6.2	3.1	9.26
20	9.9	1.6	11.5	9.5	1.8	11.3	8.9	2.1	11.0	8.6	2.2	10.8	8.1	2.5	10.6	7.5	2.8	10.3	7.1	3.1	10.2	
28HT	-15	2.7	1.7	4.4	2.5	1.9	4.4	2.4	2.0	4.4	1.9	2.3	4.2									
	-10	3.5	1.6	5.1	3.2	1.8	5.0	3.0	2.0	5.0	2.6	2.3	4.9	1.8	2.8	4.6						
	-5	4.2	1.6	5.8	3.9	1.8	5.7	3.7	2.0	5.7	3.5	2.2	5.7	2.9	2.8	5.6	2.5	2.8	5.3			
	0	5.1	1.6	6.6	4.4	1.8	6.2	4.4	2.0	6.4	4.2	2.2	6.3	3.7	2.6	6.2	3.6	2.9	6.4	3.2	3.0	6.2
	5	6.7	1.6	8.3	6.4	1.8	8.2	6.1	2.0	8.1	5.8	2.2	8.0	5.5	2.5	8.0	5.0	2.7	7.7	4.5	3.0	7.5
	10	7.8	1.6	9.4	7.4	1.8	9.2	7.1	2.0	9.1	6.7	2.2	8.9	6.4	2.4	8.8	5.8	2.7	8.5	5.2	2.9	8.1
	15	9.0	1.6	10.5	8.5	1.8	10.3	8.1	2.0	10.1	7.8	2.1	9.9	7.4	2.4	9.8	6.9	2.7	9.6	6.5	2.9	9.5
20	10.2	1.5	11.7	9.8	1.7	11.5	9.2	2.0	11.2	8.9	2.1	11.0	8.4	2.4	10.8	7.9	2.7	10.5	7.4	2.9	10.4	
35H	-15	3.3	2.3	5.6	3.0	2.5	5.5	2.4	2.8	5.2	1.9	3.1	5.1									
	-10	3.9	2.2	6.1	3.6	2.5	6.1	3.2	2.8	6.0	2.9	3.1	6.0	2.0	3.6	5.6						
	-5	4.7	2.2	6.9	4.4	2.5	6.9	3.8	2.8	6.6	3.3	3.1	6.4	2.6	3.5	6.1	2.0	4.0	6.0			
	0	5.7	2.2	7.9	5.4	2.5	7.8	5.1	2.8	7.8	4.4	3.1	7.5	3.9	3.5	7.4	3.2	4.0	7.2	2.8	4.3	7.1
	5	7.9	2.2	10.1	7.6	2.5	10.0	7.1	2.8	9.9	6.7	3.1	9.8	6.3	3.5	9.8	5.7	4.0	9.7	5.2	4.3	9.5
	10	9.2	2.2	11.4	8.9	2.4	11.3	8.4	2.7	11.1	7.9	3.1	11.0	7.4	3.5	10.9	6.8	3.9	10.7	5.9	4.3	10.2
	15	10.7	2.2	12.9	10.2	2.4	12.6	9.7	2.7	12.4	9.2	3.0	12.2	8.6	3.4	12.0	8.0	3.8	11.8	7.0	4.1	11.2
20	12.2	2.1	14.3	11.7	2.4	14.1	11.1	2.7	13.8	10.5	3.0	13.5	9.9	3.3	13.2	9.2	3.8	13.0	8.3	4.1	12.5	
35HT	-15	3.5	2.1	5.6	3.2	2.3	5.4	2.5	2.6	5.1	2.1	2.9	5.0									
	-10	4.1	2.0	6.1	3.8	2.3	6.1	3.5	2.5	6.0	2.9	2.9	5.8	2.2	3.4	5.6						
	-5	4.8	2.0	6.9	4.6	2.3	6.8	4.1	2.5	6.6	3.6	2.8	6.4	2.8	3.3	6.1	2.3	3.7	6.0			
	0	5.8	2.0	7.9	5.5	2.3	7.8	5.3	2.5	7.8	4.7	2.8	7.5	4.0	3.3	7.3	3.6	3.6	7.2	2.9	4.1	7.0
	5	8.0	2.0	10.1	7.7	2.3	10.0	7.3	2.6	9.9	7.1	2.8	9.9	6.4	3.3	9.7	6.2	3.6	9.7	5.5	4.0	9.5
	10	9.3	2.0	11.4	9.0	2.3	11.2	8.6	2.5	11.1	8.2	2.8	11.0	7.5	3.3	10.8	7.1	3.6	10.7	6.2	3.9	10.2
	15	10.8	2.0	12.8	10.3	2.2	12.6	9.9	2.5	12.4	9.5	2.7	12.2	8.8	3.2	12.0	8.2	3.6	11.8	7.2	3.9	11.1
20	12.3	1.9	14.3	11.8	2.2	14.0	11.2	2.5	13.7	10.8	2.7	13.5	10.1	3.1	13.2	9.4	3.6	13.0	8.5	3.9	12.4	
50H	-15	4.5	2.7	7.4	3.9	3.1	7.3	3.4	3.7	6.9	2.8	4.0	6.5									
	-10	5.5	2.7	8.4	5.1	3.1	8.3	4.4	3.6	7.2	3.8	4.0	7.1	2.9	4.6	7.1						
	-5	6.7	2.7	9.6	6.3	3.1	9.6	5.7	3.5	9.2	4.9	3.8	9.2	4.9	4.5	8.9	4.3	4.9	8.6			
	0	8.0	2.7	11.0	7.5	3.0	10.9	6.8	3.5	10.8	6.2	3.7	10.7	6.3	4.5	10.6	5.5	4.8	10.3	5.1	5.3	9.7
	5	10.5	2.7	13.6	9.9	3.0	13.3	9.3	3.5	13.0	9.0	3.7	12.7	8.2	4.2	12.4	7.6	4.7	12.1	7.0	5.3	11.1
	10	12.1	2.7	15.6	11.5	3.0	15.2	10.8	3.4	14.9	10.4	3.7	14.4	9.6	4.1	14.0	9.0	4.6	13.6	8.3	5.2	12.6
	15	13.8	2.6	17.8	13.3	3.0	17.4	12.5	3.3	16.9	12.0	3.6	16.3	11.0	4.1	15.8	10.4	4.6	15.3	9.7	5.1	14.8
20	15.6	2.6	20.2	15.0	2.9	19.8	14.2	3.3	19.2	13.5	3.6	18.4	12.6	4.0	17.7	11.9	4.5	17.1	10.7	5.0	16.5	
50HT	-15	4.9	2.8	7.6	4.3	3.2	7.5	3.7	3.7	7.4	3.1	4.0	7.1									
	-10	6.0	2.8	8.6	5.6	3.1	8.5	4.8	3.6	8.4	4.1	4.0	8.1	2.5	4.6	7.1						
	-5	7.3	2.8	9.9	7.0	3.1	9.8	6.3	3.5	9.8	5.4	3.8	9.3	4.6	4.5	9.1	3.9	5.0	8.9			
	0	8.8	2.8	11.3	8.4	3.1	11.2	7.5	3.5	11.0	6.8	3.7	10.6	6.1	4.2	10.5	5.2	4.9	10.0	4.7	5.1	9.8
	5	10.8	2.8	13.3	10.2	3.1	13.1	9.5	3.5	13.0	9.1	3.7	12.8	8.1	4.2	12.3	7.4	4.8	12.1	6.8	5.0	11.8
	10	12.5	2.7	15.0	11.8	3.1	14.7	11.1	3.4	14.5	10.7	3.7	14.3	9.5	4.2	13.7	8.9	4.8	13.5	8.2	5.0	13.2
	15	14.3	2.7	16.8	13.7	3.1	16.5	12.8	3.4	16.2	12.3	3.6	15.9	11.0	4.2	15.2	10.4	4.8	14.9	9.6	5.0	14.5
20	16.2	2.7	18.7	15.5	3.1	18.3	14.6	3.4	17.9	14.0	3.6	17.6	12.6	4.2	16.7	11.8	4.8	16.3	10.6	5.0	15.4	



# Air-to-water reversible heat pumps and water chillers

AQUALIS 2

## HEATING CAPACITIES

### Aqualis 2 - reversible

AQUALIS 2	Ext Air Temp °C	Hot water outlet temp. (°C)																					
		25			30			35			40			45			50			55			
		Pf kW	Pa kW	Pc kW	Pf kW	Pa kW	Pc kW	Pf kW	Pa kW	Pc kW	Pf kW	Pa kW	Pc kW	Pf kW	Pa kW	Pc kW	Pf kW	Pa kW	Pc kW	Pf kW	Pa kW	Pc kW	
65HT	-15	5.5	3.3	8.8	5.0	3.7	8.7	4.4	4.2	8.6	3.3	4.6	7.9										
	-10	6.7	3.3	10.0	6.0	3.7	9.7	5.1	4.2	9.3	4.6	4.5	9.1	3.9	5.1	9.0							
	-5	8.3	3.3	11.6	7.0	3.7	11.4	6.4	4.1	10.5	6.0	4.5	10.5	5.3	5.0	10.3	4.8	4.9	8.6				
	0	9.9	3.2	13.1	9.5	3.7	13.2	8.7	4.1	12.8	8.0	4.5	12.5	7.5	5.0	12.5	6.9	4.8	10.3	4.6	5.3	9.7	
	5	13.9	3.2	17.1	13.0	3.7	16.7	12.1	4.1	16.2	11.3	4.5	15.8	10.3	4.8	15.1	9.2	4.7	12.1	7.5	5.3	11.1	
	10	16.2	3.2	19.4	15.4	3.6	19.0	14.5	4.1	18.6	13.4	4.4	17.8	12.5	4.7	17.2	11.4	4.6	13.6	10.2	5.2	12.6	
	15	18.6	3.2	21.8	17.7	3.6	21.3	16.7	4.1	20.8	15.5	4.4	19.9	14.7	4.7	19.4	13.8	4.6	15.3	11.9	5.1	14.8	
20	21.0	3.2	24.2	20.1	3.6	23.7	19.0	4.1	23.1	17.7	4.4	22.1	16.8	4.7	21.5	14.1	4.5	17.1	13.6	5.0	16.5		
75HT	-15	6.7	4.0	10.7	5.8	4.5	10.3	5.4	4.9	10.3	4.7	5.3	10.0										
	-10	8.1	4.0	12.1	7.4	4.5	11.9	6.8	4.9	11.7	6.1	5.3	11.4	4.3	5.9	10.2							
	-5	9.8	4.0	13.8	9.1	4.5	13.5	8.5	4.8	13.3	7.9	5.2	13.1	6.9	5.9	12.8	5.7	5.0	8.9				
	0	11.8	4.0	15.8	11.0	4.5	15.5	10.4	4.8	15.2	9.7	5.2	14.9	8.8	5.8	14.6	7.7	4.9	10.0	6.9	5.1	9.8	
	5	15.1	4.0	19.1	14.5	4.3	18.8	13.8	4.8	18.6	13.3	5.2	18.5	12.7	5.7	18.4	11.3	4.8	12.1	10.1	5.0	11.8	
	10	17.6	3.9	21.6	16.9	4.3	21.2	16.0	4.8	20.8	16.5	4.1	20.6	14.8	5.7	20.5	13.6	4.8	13.5	12.4	5.0	13.2	
	15	20.3	3.9	24.2	19.5	4.3	23.8	18.4	4.8	23.2	17.7	5.1	22.8	17.0	5.7	22.7	15.9	4.8	14.9	14.9	5.0	14.5	
20	23.0	3.9	26.9	22.0	4.3	26.3	21.1	4.7	25.8	20.1	5.1	25.2	19.4	5.7	25.1	17.9	4.8	16.3	17.4	5.0	15.4		

## COOLING CAPACITIES AND POWER INPUT LEVELS

### Aqualis 2 - cooling only

AQUALIS 2	Cold water temp. (°C)	External air temperature									
		28		32		36		40		45	
		Pf kW	Pa kW	Pf kW	Pa kW	Pf kW	Pa kW	Pf kW	Pa kW	Pf kW	Pa kW
35T	5	8.4	2.9	8.3	3.1	7.9	3.4	7.5	3.7	6.9	4.1
	6	8.7	2.9	8.4	3.2	8.1	3.4	7.7	3.7	7.1	4.1
	7	9.0	3.0	8.9	3.2	8.4	3.5	7.9	3.7	7.4	4.1
	8	9.3	3.0	9.2	3.2	8.7	3.5	8.2	3.8	7.7	4.2
	12	10.5	3.1	10.4	3.3	9.8	3.6	9.3	3.9	8.7	4.3
	16	11.8	3.2	11.6	3.4	11.0	3.7	10.5	4.0		
	18	12.5	3.3	12.3	3.5	11.7	3.8	11.1	4.1		
20	13.1	3.3	13.0	3.6	12.3	3.9	11.6	4.2			
50T	5	11.9	3.8	11.8	4.1	11.2	4.5	10.6	4.9	9.8	5.5
	6	12.3	3.8	12.2	4.1	11.6	4.5	10.9	5.0	10.1	5.5
	7	12.7	3.8	12.5	4.2	11.9	4.5	11.3	5.0	10.4	5.5
	8	13.1	3.9	12.9	4.2	12.3	4.6	11.7	5.0	10.6	5.6
	12	14.6	4.0	14.5	4.3	13.8	4.7	13.1	5.2	12.2	5.7
	16	16.3	4.2	16.3	4.5	15.5	4.9	14.6	5.3		
	18	17.2	4.3	17.1	4.6	16.3	5.0	15.5	5.4		
20	18.0	4.4	17.9	4.7	17.1	5.1	16.3	5.5			
65T	5	14.4	4.4	14.3	4.6	13.6	5.0	12.9	5.4	11.8	6.0
	6	14.9	4.4	14.8	4.7	14.1	5.0	13.3	5.4	12.4	6.0
	7	15.4	4.4	15.2	4.7	14.6	5.1	13.8	5.5	12.7	6.0
	8	15.9	4.5	15.7	4.7	14.9	5.1	14.2	5.5	13.2	6.0
	12	18.0	4.6	17.8	4.9	17.0	5.3	16.2	5.7	15.0	6.3
	16	20.2	4.8	20.0	5.1	19.1	5.5	18.2	5.9		
	18	21.6	4.9	21.3	5.2	20.4	5.6	19.4	6.0		
20	22.8	5.0	22.5	5.2	21.5	5.6	20.5	6.1			
75T	5	17.3	5.7	17.0	5.9	16.2	6.4	15.3	6.9	14.3	7.6
	6	17.8	5.7	17.6	5.9	16.7	6.5	15.8	7.0	14.8	7.7
	7	18.4	5.8	18.1	6.0	17.3	6.5	16.4	7.0	15.2	7.8
	8	19.0	5.8	18.7	6.1	17.8	6.6	16.9	7.1	15.8	7.8
	12	21.4	6.1	21.2	6.3	20.2	6.8	19.2	7.4	17.9	8.1
	16	24.1	6.4	23.9	6.6	22.7	7.2	21.7	7.7		
	18	25.6	6.6	25.3	6.8	24.2	7.3	23.0	7.9		
20	27.0	6.8	26.6	7.0	25.5	7.5	24.4	8.0			

Pf = Gross cooling capacity

Pa = Compressor power input + control + fan(s)

The capacity and input level calculations include the fan speed variation.



# Air-to-water reversible heat pumps and water chillers

## AQUALIS 2

### PUMP SPECIFICATIONS

#### Available pressure in system

AQUALIS 2 - 20

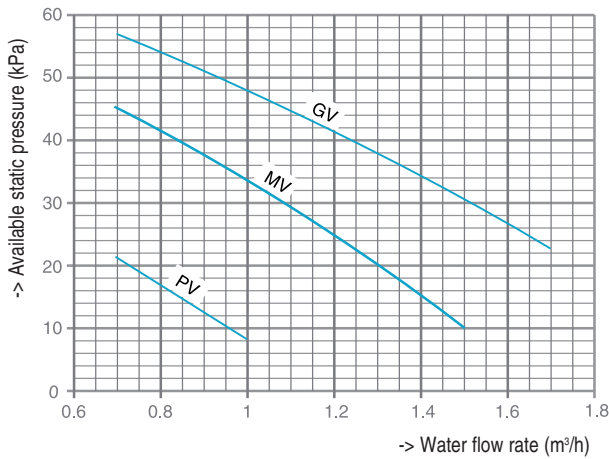

AQUALIS 2 - 28

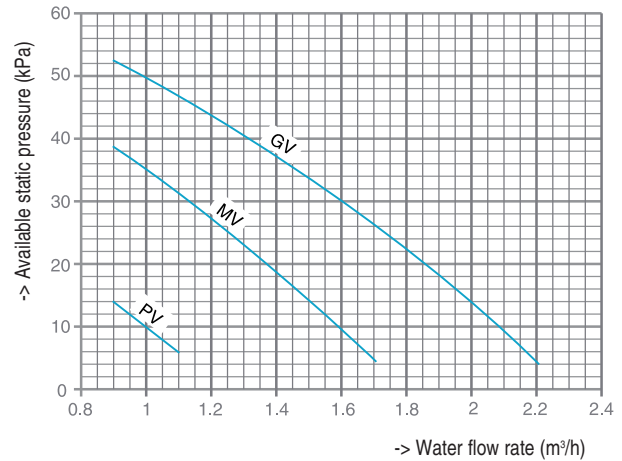

AQUALIS 2 - 35

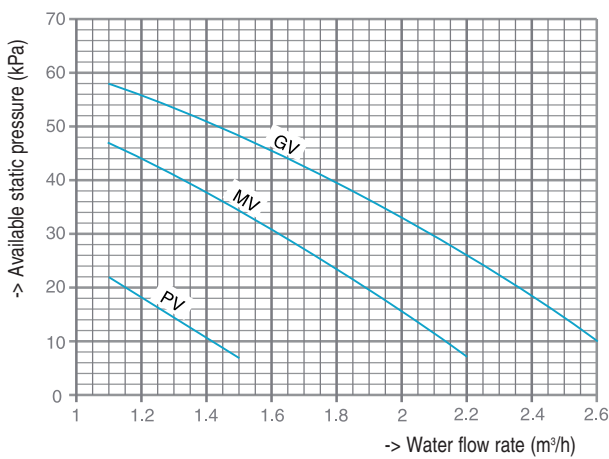

AQUALIS 2 - 50

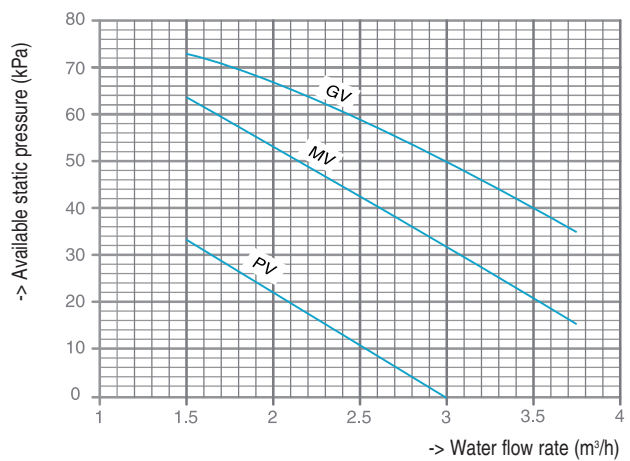

AQUALIS 2 - 65

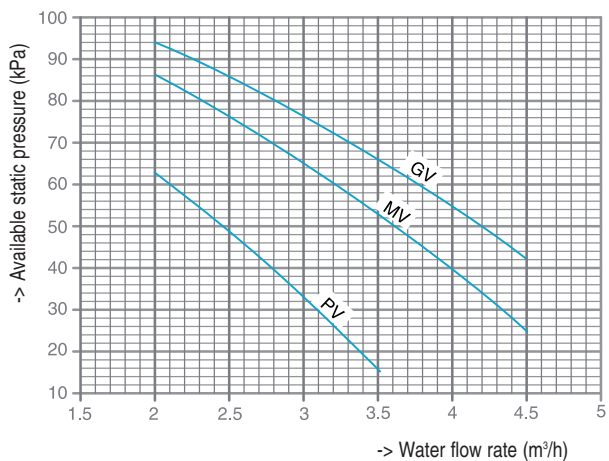

AQUALIS 2 - 75

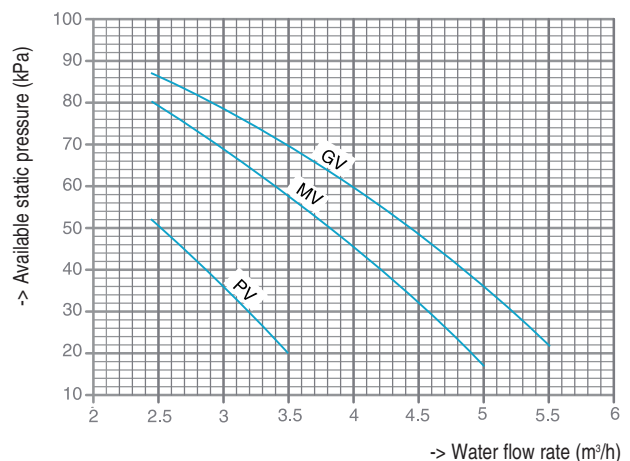

The available pressure curves are given for pure water.

Subtract 5 kPa from the available pressures for systems using 40% monopropylene glycol (heating mode).



# Air-to-water reversible heat pumps and water chillers

## DIMENSIONS

### AQUALIS 2 - 20 - 28 - 35

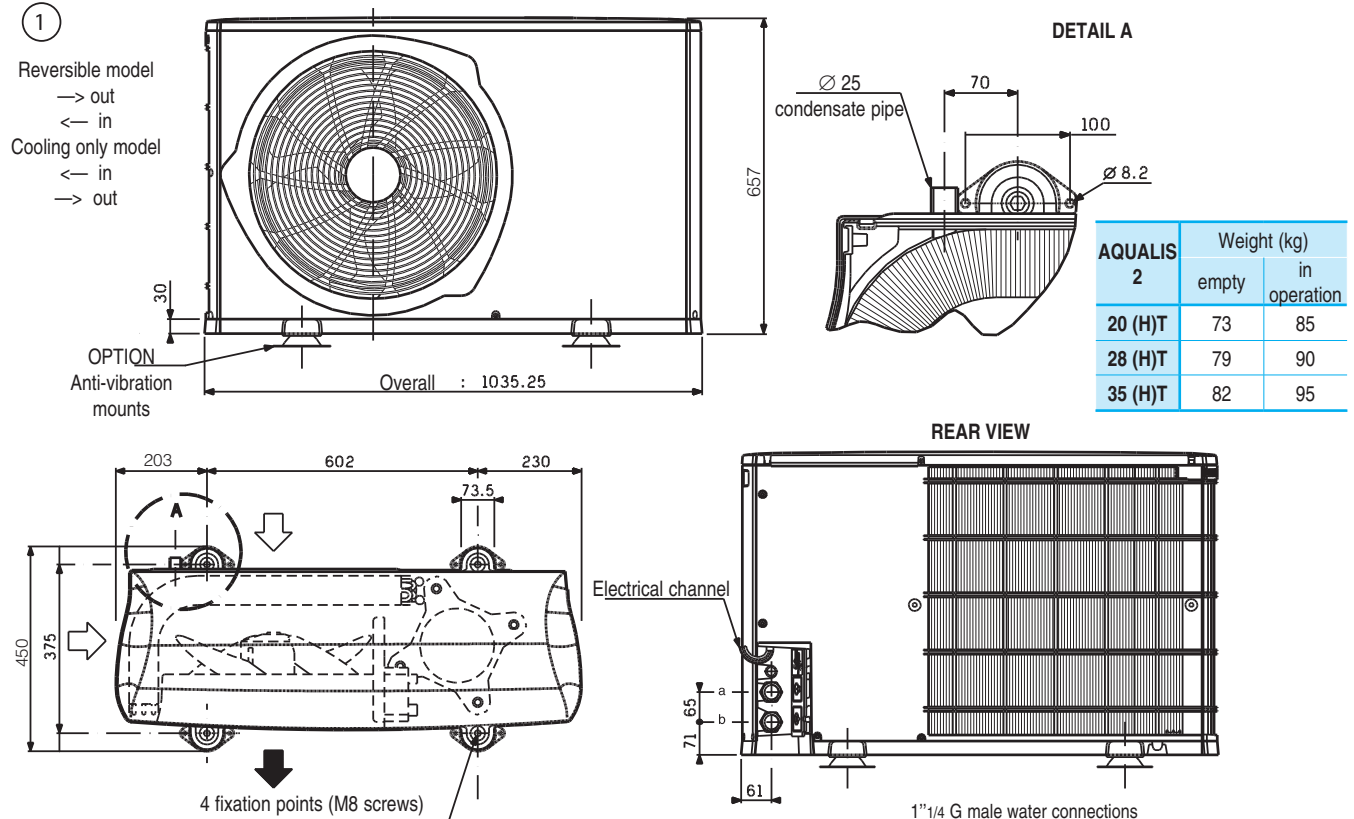

### AQUALIS 2 - 50 - 50T - 65T - 75T

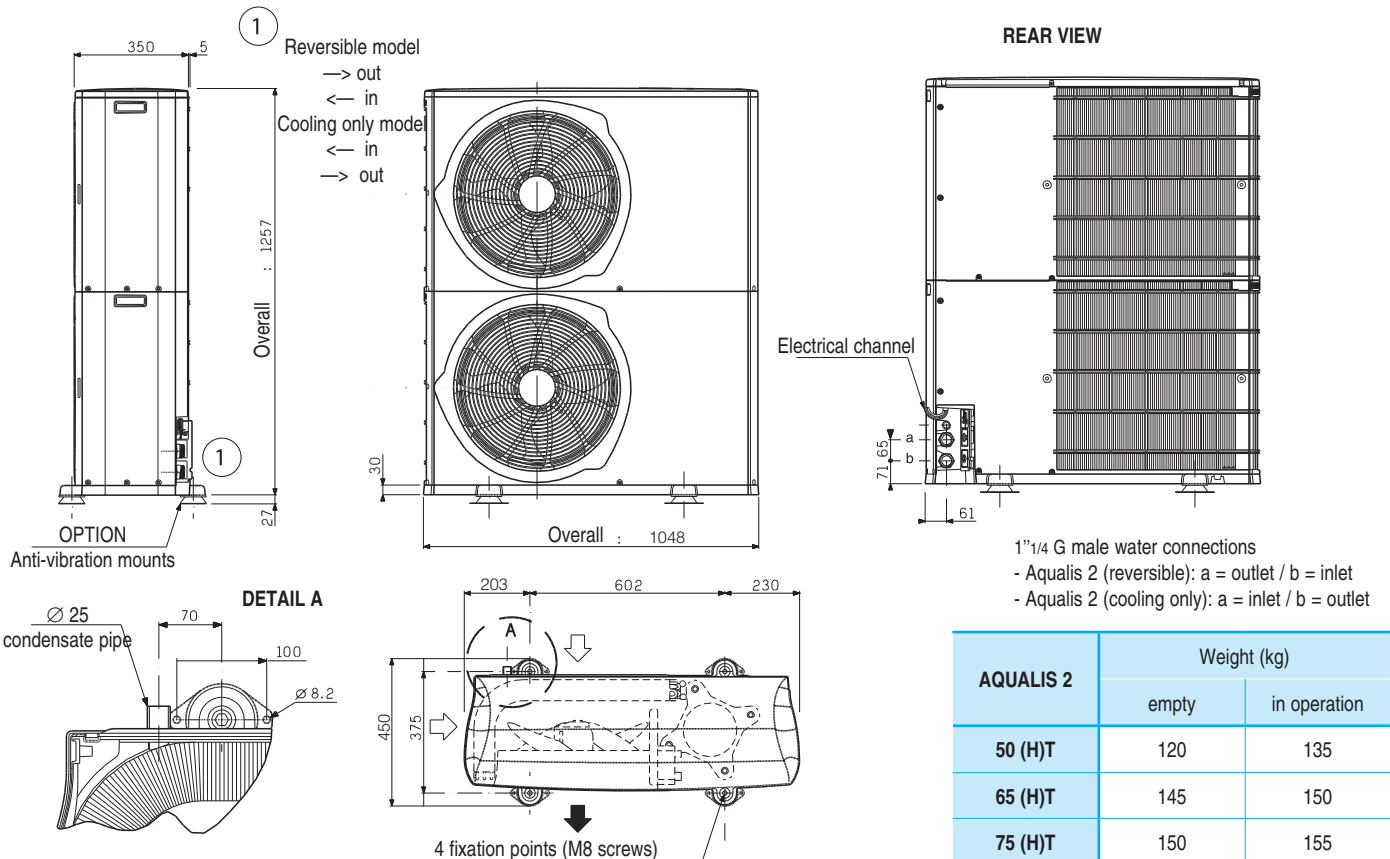



# Air-to-water reversible heat pumps and water chillers

## AQUALIS 2

### TECHNICAL CHARACTERISTICS

AQUALIS 2		20H	28H	35H	50H	20HT	28HT	35T 35HT	50T 50HT	65T 65HT	75T 75HT	
Compressor	Quantity	1										
	Type	SCROLL										
	Oil content	L	1.1	1.25	1.66	1.1	1.25	1.95	1.66	1.77		
Refrigerant fluid		POE oil R410A										
Refrigerant fluid load	Cooling only	kg	-					1.42	2.4	3.1	3.0	
	Reversible	kg	1.37	1.6	1.62	2.67	1.37	1.6	1.62	2.67	3.2	2.85
Crankcase heater current and power		W/A	45W / 0.2A option*									
Coil type		Grooved copper tubes with aluminium fins										
Water type heat exchanger	Water content	L	1.04	1.24	1.62	2.38	1.04	1.24	1.62	2.38	2.76	3.7
	Type	Axial										
Fan	Number of fans		1		2		1		2			
	rpm		718	897		718		897	718	897		
Accelerator pump		3 speeds										
Expansion vessel	L	5		8		5		8				
	Expansion vessel pre-charge pressure	bar	1.5									
Hydraulic module	Maximum service pressure	bar	4									
	Maximum volume of RFHC system** maximum water temperature of 40°C pure water/40%MPG	L	294 / 150		471 / 240		294 / 150		471 / 240			
	Maximum volume of radiator system** maximum water temperature of 70°C/90°C pure water/40% MPG	L	88 / 54		141 / 87		88 / 54		141 / 87			
	Minimum pure water content for smooth unit operation	L	35	48	61	75	35	48	61	82	95	123
Weight	Empty	kg	73	79	82	120	73	79	82	120	145	150
	In operation		85	90	95	135	85	90	95	135	150	155

\* Compulsory in cooling mode when outdoor temperatures fall below 0°C

\*\* An additional expansion vessel is needed for larger volumes

### SOUND LEVELS\*

AQUALIS 2		20	28	35	50	65	75
Sound pressure levels	dB(A)	44	47	51	51	53	53

\* measured at 5 metres from unit, 1.5 metres from ground, in a free field, directivity 2

### ELECTRICAL SPECIFICATIONS

AQUALIS 2		20HT	28HT	35H	50H	20HT	28HT	35T 35HT	50T 50HT	65T 65HT	75T 75HT	
Rated voltage of unit		230V - 1ph +N+Earth - 50Hz					400V - 3ph +N+Earth - 50Hz					
Compressors	Maximum operating current	A	12.9	17.5	22.2	29.8	4.8	6.4	7.6	10.3	11.2	14.3
Fans	Maximum operating current	A	0.47	0.74	0.47x2	0.47	0.74	0.47x2	0.74x2			
Accelerator pump	Output per unit	min	50	115	120	50	115	120	180			
	Output per unit	max	140	205	210	40	205	210	400			
	Rated current	min	0.32	0.6	0.65	0.32	0.6	0.65	0.91			
	Rated current	max	0.61	1	1.1	0.61	1	1.1	2.02			
Current of entire unit		A	14	19	24	31.8	8.1	10.9	9.3	13.3	14.7	17.8
Starting current		A	22	29	39	43	30	40	48	64	74	101
Electrical wiring (not supplied) (1)		mm <sup>2</sup>	3G4	3G6	3G10 (2)	5G2.5	5G4					
C or D curve circuit breaker (not supplied)		Am	16	20	25	32	10	16			20	
Thermostat, pool sensor, On/Off input connections		mm <sup>2</sup>	0.2 - 1.5									
Control circuit, connection kit		mm <sup>2</sup>	1.5									

(1) Cable with 2 or 3 charged PVC conductors for temperatures below 50°C and for a maximum length of 30 m.

Note: For other conditions, refer to French standard NF C 15-100.

(2) A 3G6 cable with PVC/V2-K (high temperature) conductors may be used for the 50/50H model.



# Air-to-water reversible heat pumps and water chillers

## SCHEMATIC INSTALLATION DIAGRAM

### Residential and/or RFHC system comfort units

AQUALIS 2

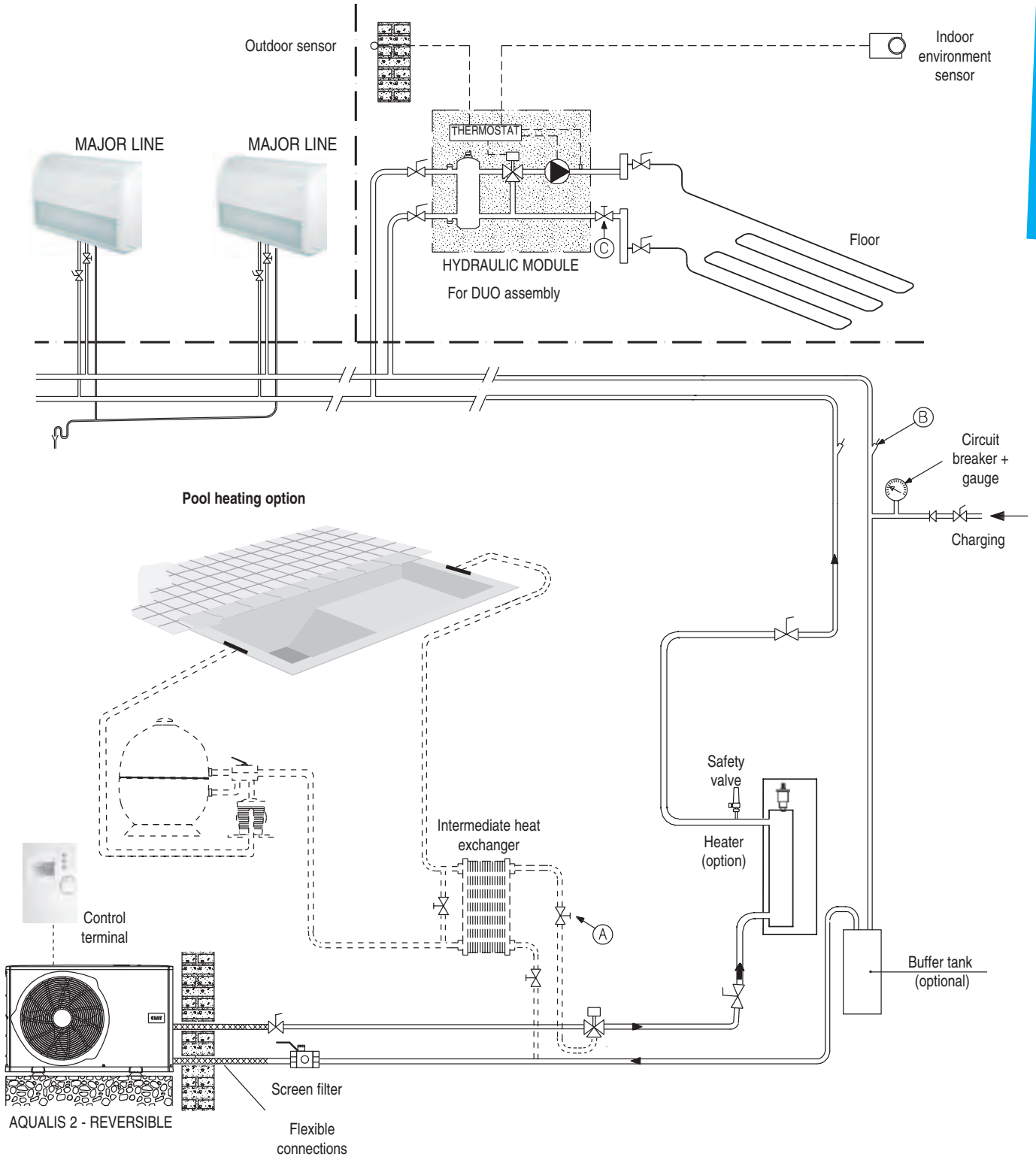

- (A) Shut-off valves
- (B) Thermometer pockets
- (C) Control valves

**Note:** the schematic diagrams herein are provided for information only. Under no circumstances do they constitute actual installation diagrams.

### ASSEMBLY RECOMMENDATIONS

#### Installation

Aqualis 2 units are designed to be installed outdoors on a home deck/patio or in a garden.

- Nothing should obstruct the air flow over the coil or the fan discharge.
- Carefully consider where to install the unit and choose a location appropriate for the surrounding environment (noise levels, integration on site, etc.).
- Enough clearance should be left around the unit to allow for connections, servicing and maintenance.

#### Clearance to be left around the unit

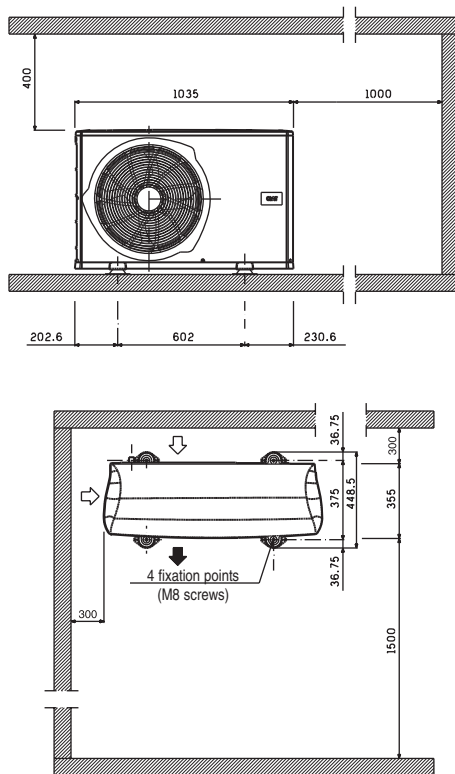

#### Electrical connections

All the information needed to wire the system is provided on the wiring diagram supplied with the unit. The diagram should be followed to the letter.

Wiring must be carried out in accordance with accepted engineering practice and conform to the regulations in force.

A cut-off switch and circuit breaker must be installed on the unit by the fitter.

**NOTE:** To protect the unit from freezing temperatures, leave it on to allow the water to continue flowing through the water circuit. Add glycol if the outdoor temperature falls below 0°C.

#### Hydraulic connections

Hydraulic connections are to be made in accordance with good engineering practice.

To prevent transmitting noise through the ground or pipes, we recommend using hoses for the hydraulic connections and placing anti-vibration mounts under the unit.

- Place a screen filter with a maximum particle size of no more than  $\varnothing 600 \mu\text{m}$  on the water circuit to protect it from fouling.

#### Commissioning

- Follow the instructions given in our installation and maintenance manuals.

#### Servicing

- Follow the owner's manual.
- Take out a maintenance contract.



# Air-to-water reversible heat pumps and water chillers

This document is non-contractual. As part of its policy of continual product improvement, CIAT reserves the right to make any technical modification it feels appropriate without prior notification.

## Head office

Avenue Jean Falconnier - B.P. 14  
01350 - Culoz - France  
Tel.: +33 (0)4 79 42 42 42  
Fax: +33 (0)4 79 42 42 10  
info@ciat.fr - www.ciat.com



## CIAT Service

Tel. : 08 11 65 98 98 (0,15 €/ mn)  
Fax : 08 26 10 13 63 (0,15 €/ mn)

ISO9001 • ISO14001  
OHSAS 18001



Compagnie Industrielle d'Applications Thermiques - S.A. with a registered capital of 26 728 480 €- R.C.S. Bourg-en-Bresse B 545 620 114