



# BLACK HT

Thermal power (A7;W45) 35 ÷ 238 kW  
Cooling power (A35;W7) 32 ÷ 201 kW

High efficiency and high temperature air/water heat pump  
with axial fans and semihermetic reciprocating compressors





# BLACK HT

High efficiency and high temperature air/water heat pump with axial fans and semihermetic reciprocating compressors



CLASS A



MULTI-PURPOSE



LOW NOISE



R134a



TWO CIRCUITS



WATER  
UP TO 80°



HORIZONTAL AIR  
DISCHARGE



SUPERVISION  
VIA WEB



MANAGEMENT  
OF UP TO 4-6  
UNITS WITH  
MINIBOSS

New series of dedicated heat pumps with semihermetic reciprocating compressors.

**Standard version** in 12 sizes

Thermal power (A7;W45) 35 ÷ 238 kW  
Cooling power (A35;W7) 32 ÷ 201 kW

BLACK HT is a series of heat pumps in R134a, with the possibility of having water at 80°.

## STRONG POINTS

- > High temperature of the produced water: up to 80°C
- > Extended limits of operation in heat: air up to -20°
- > Automatic management of DHW
- > DWS always available (multi-purpose)
- > Intelligent management of defrosts
- > Subcooler and increased fin pitch
- > /LN Silent version
- > Supervision via web
- > Management of up to 4-6 units with proprietary control
- > Dual refrigerant circuit starting from size 70



## CONTENTS

<b>1</b>	Technical features _____	p. 6
<b>2</b>	Technical data _____	p. 19
<b>3</b>	Electrical data _____	p. 21
<b>4</b>	Operating limits _____	p. 22
<b>5</b>	Pumps and exchanger data _____	p. 23
<b>6</b>	Cooling and heating capacity _____	p. 24
<b>7</b>	Dimensional drawing _____	p. 31



# STANDARD UNIT

## STRUCTURE

In galvanised sheet metal and painted at 180°C with RAL7035 polyester powder, that gives high resistance against atmospheric agents.

The panels can be easily removed for complete access to the internal components. All structures are equipped with two condensation collection trays with relative drain (one for each coil).

## COMPRESSOR

Semi-hermetic reciprocating compressor, complete with thermal protection included in the windings of the electric motor, crankcase heater and rubber vibration damper supports. The compressors used in this series are specifically designed to work in heat pump at very high temperatures. The optimisation of the high value compression ratio allows higher efficiencies if compared with traditional scroll compressors. The compressor is cooled by a system inside the unit. This cooling system allows an outlet water temperature of 80°C.

## INTERNAL EXCHANGER (SYSTEM SIDE)

Brazed plates made of AISI 316 stainless steel, insulated with closed cell foam cladding that reduces heat loss and prevents the formation of condensation. The exchanger is equipped with a temperature probe for ice protection, a probe for detecting the inlet and outlet water temperature and a pallet flow switch supplied as standard.

## EXTERNAL EXCHANGER (SOURCE SIDE)

Consists of two coils with copper pipes and high exchange surface aluminium finning with fin pitch dimensioned to maximise heat exchange and reduce noise. The fin clearance of the exchanger was increased to allow the unit to work at very low outdoor temperatures and at high concentrations of humidity. At the base of the exchanger is the subcooler, a further refrigerant circuit that prevents the formation of ice in the lower part of the coil and facilitates the flow of condensation during defrosts. The effects of the subcooler are: the reduction of number of defrosts and the certainty of having a clean exchanger at the end of defrost.

## FANS

Helicoidal fan directly coupled with electric motor, made of plastic with the blade profile with WINGLET, a special mould in the end part of the blades that allows noise reduction and an increase in ventilation performances. The control manages the fan speed through a phase-cut speed regulator, in order to optimise the operating conditions, efficiency, and allow the unit to work in heat pump, even with high outdoor temperatures.

This adjustment also reduces the level of noise of the unit, in fact, the typical conditions in which the control will modulate the fan speed are the night-time and spring and autumn. This ensures that, whenever there is the opportunity, the machine decreases the fan speed to minimum and, therefore, noise.

The fans are helicoidal type, directly coupled with 6-pole electric motor, with IP 54 protection degree, with shaped nozzles and accident prevention grille according to UNI EN 294.

## REFRIGERANT CIRCUIT

Includes:

- > inlet valve in the liquid and suction line
- > liquid and humidity warning light
- > solenoid valve
- > 4-way reverse valve
- > check valve
- > drier filter
- > electronic expansion valve
- > high pressure transducer
- > low pressure transducer
- > high and low pressure switches
- > safety valve
- > liquid receiver
- > suction separator
- > subcooler

## ELECTRIC PANEL

The electric panel consists of:

- > main cut-out switch
- > Main circuit breaker and fuses to protect the auxiliary and power circuits
- > compressor contactor
- > fan revolution regulator for condensation and evaporation control
- > contactor and pump overload cut-out (version 1P, 2P and 1R)
- > general alarm dry contacts
- > microprocessor controller

The standard power supply is 400V/3~/50Hz for all sizes.

## CONTROL

Microprocessor control for managing the following functions:

- > Water temperature adjustment with inlet control
- > Ice protection
- > Compressor timing
- > High pressure pre-alarm management
- > Compressor high flow temperature alarm management
- > Alarm signal
- > Alarm reset
- > Digital input for external ON-OFF
- > Digital input for summer/winter selection

The control allows display of the following information:

- > Outlet water temperature
- > Inlet water temperature
- > Condensation pressure
- > Evaporation pressure
- > Outdoor air temperature
- > Set differential and temperature set
- > Description of alarms
- > Pump and compressor operation counter
- > Alarm history

Some functions are only available with the unit properly configured. Some functions must be enabled from the control.

## CONTROLS AND SAFETY DEVICES

- > Utility water temperature control probe (located at exchanger inlet)
- > Antifreeze probe that activates the antifreeze alarm (manual reset)
- > High pressure switch (automatic reset with limited interventions)
- > Low pressure switch (automatic reset with limited interventions)
- > Standard supplied mechanical pallet flow switch (manual reset)
- > Condensation pressure control via speed regulator for operation with low outdoor temperatures
- > Evaporation pressure control via speed regulator for operation with high outdoor temperatures in DHW production or recovery
- > High pressure safety valve
- > Compressor over-temperature protection

## TESTING

The units are tested in both summer and winter operation at the factory and are despatched filled with oil and coolant.

## STANDARD EQUIPMENT

- > Sliding defrost management
- > Compressor stop for outdoor air temperature below the operating limits
- > Main disconnecting device
- > Power and auxiliary circuit protection
- > Microprocessor control
- > Counter for compressors and pumps
- > Alarm History
- > Condensation and evaporation control with fan revolution regulator
- > Flow switch (supplied)
- > Directive 97/23/EEC (PED) Certification
- > Remote On/Off from standard digital input
- > Summer/Winter from standard digital input

# OPTIONS

## CONSTRUCTIVE CONFIGURATIONS

### /LN Version silenced unit

The unit, in addition to the basic version components, includes the compressor compartment acoustically insulated with sound-absorbing and soundproof material. The choice of coupling of the materials has allowed the removal of the frequencies generated by compressors and pumps.

### /OD Version unit with horizontal discharge (available up to size 75)

The unit in this version has horizontal air discharge. This version allows reduction of the unit height or installation where vertical discharge is not admitted for logistical reasons or noise. If equipped with EC fan high pressure, it is possible to convey the air flow for discharge through ducts.



### /DWS Version multi-purpose heat pump

In this set-up, the unit is equipped with two utility exchangers: one on the system side for air conditioning and heating, and one exclusively for the production of DHW.

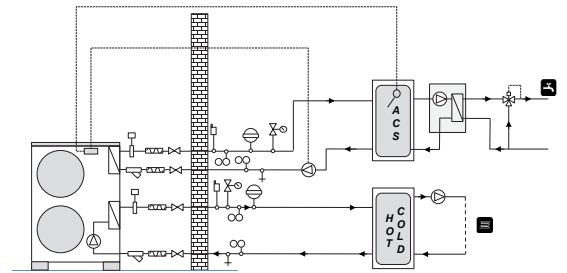

On the system side exchanger, the unit is able to produce hot or cold water to meet, depending on the seasons, the heating and cooling requirements of the building. In the sanitary exchanger, the unit produces high temperature water to be sent to the storage tank outside the machine, selected and dimensioned according to the system requirements. Depending on the season, the unit works with different modes: the passage through various modes of operation (within the season) is automatic through the reading of the temperature probes and of the set-points set. Switching logics and times are designed to ensure maximum system efficiency and reliability.

It is compulsory to associate this configuration to a suitably sized boiler in which to store high temperature water; we recommend a volume of at least 20÷25 l per thermal kW of the unit. The boiler must be provided with sump for the insertion of the DHW operating probe, located in the top part, through which the unit controller monitors the need to produce DHW.



## SUMMER OPERATION

There are three summer modes of operation:

- > **Chiller mode:** the unit only produces chilled water for the system.
- > **Chiller mode with simultaneous production of DHW:** the unit produces chilled water for the system and DHW, simultaneously. The recovered power for the production of DHW is total.
- > **Heat pump mode for the production of DHW:** without cold load and on call of the DHW operating probe, the unit heats the water inside the DHW storage tank, using the finned tube bundle coil as evaporator. The use of the external hot air as a source of heat ensures extremely high COP.

Switching from one mode to another is entirely automatic based on a logic of priority in the production of DHW and, when there is contemporaneity of loads, recovering condensation energy for the production of DHW.

## WINTER OPERATION

There are two winter modes of operation:

- > **Heat pump mode for heating:** the unit produces hot water to system side exchanger for heating
- > **Heat pump mode for the production of DHW:** produces high temperature hot water to the connected exchanger of the DHW storage.

Switching from one mode to another is entirely automatic based on a logic of priority in the production of DHW.

In addition to the basic version components, the /DWS version includes:

- > dedicated exchanger for the production of DHW
- > recovery exchanger inlet and outlet probes
- > temperature probe to be placed on the DHW storage tank.

## HYDRAULIC MODULE OPTIONS

### /1P unit with pump

The unit includes a circulation pump on the unit. The pump is centrifugal type, with body and impeller in AISI 304 steel. The mechanical seal is designed to work with up to 40% concentration of ethylene glycol. The electric motor is three-phase with IP 55 degree of protection. The pump is complete with thermoformed insulating shell. The different models available differ for useful head to system.

### /2P unit with two pumps, one in reserve to the other

The unit includes two circulation pumps on the unit, one in reserve to the other, managed in rotation on an hourly basis and with automatic switching in case of failure. The pump is of centrifugal type, with body and impeller in AISI 304 steel. The mechanical seal is designed to work with up to 40% concentration of ethylene glycol. The electric motor is three-phase with IP 55 degree of protection. The pump is complete with thermoformed insulating shell. The different models available differ for useful head to system.

### /1R unit with DHW side pump

The unit is equipped with a DHW side pump installed inside the unit.

The pump is centrifugal type, with body and impeller in AISI 304 steel. The mechanical seal is designed to work with up to 40% concentration of ethylene glycol. The electric motor is three-phase with IP 55 degree of protection. The pump is complete with thermoformed insulating shell.

This module can be combined only with the /DWS version units and can be combined with modules /1P or /2P. The /DWS version units without the /1R module are equipped with a consent for the management of an external pump. The different models available differ for useful head to system.

### /S unit with inertial tank

The unit is equipped with a inertial tank (only available for utility and not for recovery side), installed inside the unit. The tank is sized to improve the unit's efficiency and positioned on the system's input. It is complete with closed cell heat insulation to decrease heat losses. It is compulsory to combine it with version /1P or /2P. The different models available differ in capacity.

## ACCESSORIES

All units can be configured with various accessories to better meet the requirements of the specific application in which they will be inserted. To verify availability and compatibility of the accessories with size and configuration, refer to the price list or selection software.

### HYDRAULIC CIRCUIT ACCESSORIES

- > Filling unit with pressure gauge supplied
- > Antifreeze heater
  - basic version: electric heater on utility exchanger
  - /1P, /2P and /1R version: electric heater on utility exchanger and heating cable on piping
- > 3-way valve for DHW management (supplied)
- > System pump with Pulse function
- > Water filter for system
- > Water filter for DWS version

### ELECTRIC ACCESSORIES

- > Maximum and minimum voltage relay
- > Double set-point from digital input
- > RS485 Serial interface
- > Remote user terminal
- > Electronic soft starter
- > EC Electronic fans
- > EC Electronic fans high pressure (up to size 75)
- > Compensation of set-point based on the outdoor air temperature
- > DHW Automatic management
- > DHW operating probe (standard on /DWS unit)
- > Anti-legionella function
- > Auxiliary heat source management
- > DHW production with timer
- > Single operation dry contacts
- > Management relay for external pump
- > Miniboss S
- > Miniboss M
- > Supervision via WEB

### VARIOUS ACCESSORIES

- > Rubber vibration dampers
- > Packaging in wooden crate

## MAIN DESCRIPTION FUNCTIONALITY/ACCESSORIES

### Remote ON/OFF from digital input (standard)

Remote ON/OFF from digital input (standard). This function is standard on all units and consists of a remote contact for the switching on and off of the machine via a signal that can be brought inside the building or controlled by a BMS (Building Management System) system.

### Summer/winter selection from digital input (standard)

This function is standard on all heat pumps. When turning on the unit, it is always necessary to set a mode of operation that can either be heat pump or chiller. Through this remote contact it is possible to change this mode of operation also from inside the building and without the need to directly access the microprocessor control.

### Sliding defrosting (standard)

The control manages the defrost according to a variable intervention threshold, based on the pressures inside the unit and the outdoor air temperature. By cross-referencing this information, the control is able to identify the presence of ice on the coil, activating the defrosting sequence only when necessary, so as to maximise the energy efficiency of the unit. The dynamic management of the defrost threshold ensures that for outdoor air temperatures below -5°C, when the absolute humidity of the air is very low, defrosting is only carried out when the ice on the coil degrades its performance.

### Auxiliary heat source management (accessory)

The controller is able to manage an external heat source which, depending on the type of hydraulic connection, can be integration or back-up. The auxiliary heat source is activated when the outdoor air temperature falls below a threshold settable from control and when only the heat pump proves to be insufficient to meet the load. Activation is through the closure of a dry contact.

It is also possible to set the unit so that the controller turns off the compressors when the unit works in heat pump mode and the outdoor air temperature falls below an established minimum temperature: the controller stops the compressors before the unit goes into low pressure alarm, thus avoiding having to manually reactivate the machine.

This function is particularly useful when the heat pump is installed in an area where the outdoor air temperature definitely falls below the minimum temperature admitted by the operating limits (in agreement with the set-point set). When the outdoor air temperature returns above the set threshold temperature, the unit automatically starts working again without the need for any intervention.

For units equipped with integrated pump, this will always be kept running in order to avoid the formation of ice and guarantee, at any moment, the correct reading of the antifreeze safety and temperature probes. The stop temperature must be set according to the highest set-point temperature and in agreement with that admitted by the operating limits of the machine. A stop temperature

can be set different to the default one, as long as it is compatible with the unit's operating limits. The standard programming provides the set-point in heating set at 40/45° with a stop temperature of -20°C

Should the unit be used also for the production of DHW, the stop temperature must consider the highest water set, and the operating limits allowed.

**DHW Automatic management (accessory)**

**The accessory is not compatible with accessory tank (1PS e 2PS).**

This feature allows the unit, through a DHW operation probe (accessory), to control the temperature inside the DHW storage tank and manage a 3-way valve (accessory) outside the unit. The priority is always for the production of DHW.

Activation of the function must be requested when ordering, but it can also be configured subsequently (by qualified and authorised technical personnel), as long as the unit is connected to an appropriate hydraulic circuit. The request when ordering accessories for managing the DHW automatically involves enabling the "DHW automatic management" function.

The heat pump normally operates on the system to meet the building's comfort needs, but when the temperature of the water inside the tank drops below an established threshold, the control manages the DHW production: if the unit is operating as heat pump for heating, the 3-way valve will be switched and the set-point modified; whereas, if the unit is producing chilled water for air conditioning, the control switches the unit to heat pump mode, assigns it the set-point for DHW (normally higher than the system set-point) and turns the 3-way valve to the appropriate position. Once the temperature inside the DHW tank has reached the set value, the unit automatically goes back to producing water for the heating and air conditioning system.

**Description of winter operation**

The following situations occur during the winter season:  
 > Heating request: the temperature of the inlet water to the unit, coming from the system, is lower than expected, so the control turns on the compressor and the unit will operate until the set-point temperature is reached.

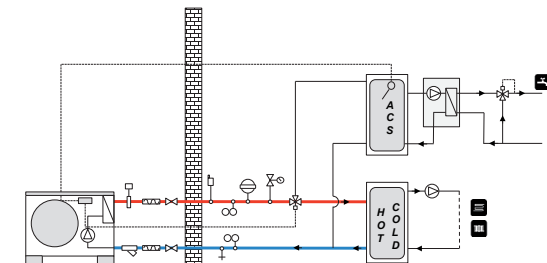

Once the wanted temperature is reached, the compressor stops and only the circulation pump remains in operation, continuing to circulate water in the system. The unit waits in this condition until the inlet water temperature drops again.

DHW request: suppose that the unit is working for the production of hot water for the heating system (45°C) and it receives a call from the DHW operating probe located inside the storage tank to produce high temperature water, since the DHW temperature has dropped. As the DHW temperature has reached the set limit (e.g. 55°C). Being the DHW is managed with the logic of priority, the control will change the set-point to 55°C and will switch the 3-way valve.

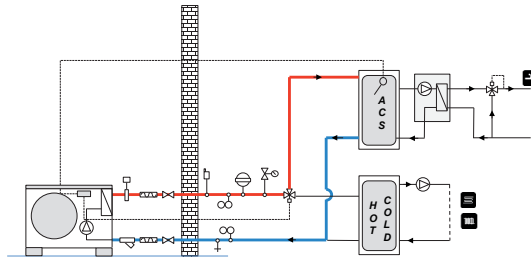

As soon as the water inside the tank reaches the requested 55°C, the control will again switch the 3-way valve to operate on the system and will bring the set-point back to 45°C.

Should it be necessary to defrost, in any mode the unit is operating, it will force the 3-way valve to be switched to system which, given the greater inertia, is less sensitive to the lowering of the temperature.

**Description of summer operation**

The following situations occur during the summer season:  
 > Cooling only: the temperature of the inlet water to the unit, coming from the system, is higher than expected, the control turns on the compressor and the unit will operate until the set-point temperature is reached.

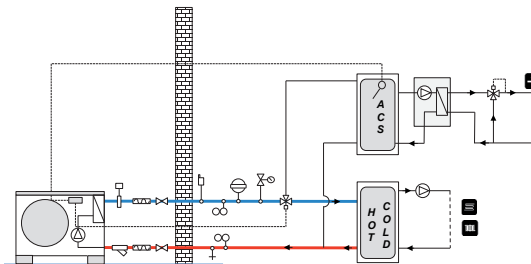

At that point, the compressor stops and only the circulation pump remains in operation, continuing to circulate water in the system. The unit waits in this condition until the inlet water temperature rises again.

> DHW request: suppose that the unit is working for the production of chilled water for the air conditioning system (7°C) and it receives a call from the DHW operating probe located inside the storage tank to produce high temperature water, since the DHW temperature has dropped below the set limit (e.g. 55°C). As the DHW is managed with the logic of priority, the control will change the unit mode from chiller to heat pump, set the set-point at 55°C and switch the 3-way valve.

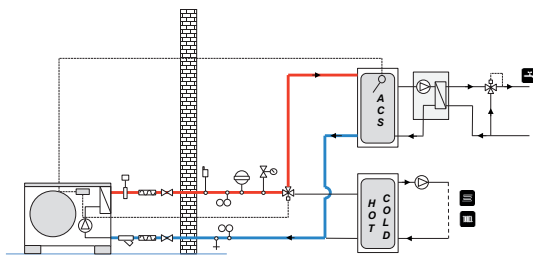

As soon as the water inside the tank reaches the requested 55°C, the control will again switch the unit to chiller mode, will turn the 3-way valve to operate on the system and will bring the set-point back to 7°C.

### DHW operating probe (accessory)

For the production of DHW, the controller requires this accessory: it is a temperature probe with 6 m cable located in an appropriate sump of the tank for the production of DHW. For proper positioning, read the "Advice for installing a heat pump" section. Standard on units in DWS version.

### Anti-legionella function (accessory)

Depending on the type of tank chosen for the production of DHW, the management of anti-legionella cycles may be necessary. The controller is able to manage them by activating, according to scheduled timing with a weekly timer, an auxiliary heat source that will perform the thermal shock on the DHW tank.

The anti-legionella function is realised exclusively through an external source (e.g. electric heater).

### System pump with Pulse function (accessory)

As standard, the unit is set to maintain the system side circulation pump always on, even when the set temperature is reached. Whereas, when the unit is equipped with this accessory, when the set-point is reached, the controller turns off the pump, reactivating it periodically, long enough to detect the water temperature. If the controller verifies that the water temperature is still in set-point conditions, it will turn off the pump again. Otherwise, the controller re-activates the compressors to meet the system requirements. This accessory allows to drastically reduce the electric absorptions due to pumping, especially during spring and autumn, when the load is extremely low.

The application of this accessory requires the compulsory presence of the "Antifreeze heaters" accessory.

### DHW production with timer (accessory)

With this accessory present, it will be possible to associate two different temperatures for the DHW to different times of the day: Normal and Saving. This allows you to decide at what time of the day the heat pump must concentrate the production of DHW, always keeping the minimum level of Saving temperature, and always managed with the logic of priority.

For example, by concentrating the production of water at Normal temperature during night-time, the best electricity rates will be exploited and production of DHW will be ensured before the time of greater consumption.

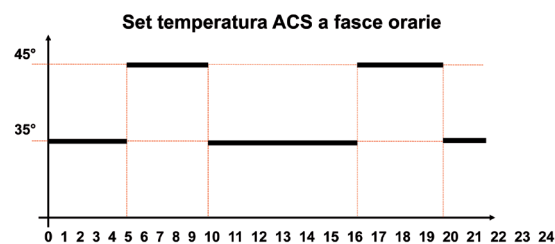

With this system, the unit never stops controlling the temperature inside the DHW tank and if hot water is occasionally used outside the regular times, the unit will give the production of DHW priority until it brings the water in the tank to a temperature equal to the Saving set-point.

### Electronic thermostatic valve (standard)

Using this accessory is particularly suitable on units having to operate in very variable heat load conditions, with strong differences of outdoor air temperature or with frequent change of operating mode, like in joint management of air conditioning, heating and production of high temperature water.

The use of the electronic thermostatic valve allows:

- > maximisation of the heat exchange to the utility exchanger
- > minimisation of the response times of the refrigerant circuit to the variations of the operating conditions and load
- > optimisation of the superheat adjustment
- > maximisation of energy efficiency



### EC Fans (accessory)

The units can be requested with EC fans, with electronic switching brushless motor. These motors with permanent magnet rotor ensure very high levels of efficiency for each working condition and allow a 15% saving on the power absorbed by each fan.

Furthermore, the microprocessor, through a 0-10V analogue signal sent to each fan, controls the condensation/evaporation through continuous adjustment of the air flow rate upon variation of the outdoor air temperature, with a further decrease of electric absorptions and a reduction of sound emissions.



### MINIBOSS S (accessory)

The Miniboss S allows connection of up to 6 units in parallel: management allows activation and deactivation of them at power steps and makes them rotate, thus allowing an identical use of all units.

The connected units must all be the same. The Miniboss S cannot control units with the DHW management active.

Directly from the Miniboss S panel it is possible to manage:

- > the system set-point
- > the summer/winter selection of all machines
- > the ON/OFF of the single units or of the entire system

This accessory is supplied in an electrical panel with the unit (to be installed in a technical compartment); it must be provided on only one machine connected in parallel and all connected units must have the same configuration. When ordering, it is compulsory to specify the number of units that must be managed to allow for proper programming of the supervisor. Furthermore, the hydraulic circuit connecting the units must compulsorily respect one of the following diagrams. For more information on the use, refer to the specific documentation.

### MINIBOSS M (accessory)

The Miniboss M allows management of up to 4 units in parallel. The main functions are:

- > Manage units with DWS configurations
- > Manage systems with a hot/cold tank for heating/air conditioning and a hot tank for the production of DHW

In addition to that also carried out by the Miniboss S:

- > the system set-point
- > the DHW set-point
- > use a compensation climate of the system set-point
- > the summer/winter selection of all machines
- > the ON/OFF of the single units or of the entire system
- > the switching of three-way valves
- > manage the operation of pumps outside the units

This accessory is supplied in an electrical panel with the unit (to be installed in a technical compartment), it must be provided on only one machine connected in parallel and all connected units must have the same configuration. When ordering, it is compulsory to specify the number of units that must be managed to allow for proper programming of the supervisor. For more information on the use, refer to the specific documentation.

### Filling unit with pressure gauge (accessory)

This accessory allows automatic loading of the hydraulic system, adjustment of the correct working pressure, always verifiable through the pressure gauge, and continuously maintains this pressure by reintegrating the missing water.

### Antifreeze heater (accessory)

This accessory consists in heaters inserted on the utility exchanger, on the pump and in the tank (based on the machine configuration) to prevent damaging the hydraulic components following the formation of ice during machine downtime. The power of the antifreeze heaters is only of a few tens of watts, depending on the unit model, meaning sufficient enough to avoid failure of the components. The control monitors (even when the unit is in stand-by) the outlet pump from the exchanger and when this detects a water temperature below or equal to 5°C (or 2°C below set-point temperature, with differential of 1°C), it turns on the pump (if present) and makes the antifreeze heaters intervene.

If the outlet water temperature reaches 4°C (or 3°C below set-point), the antifreeze alarm will also trigger, stopping the compressor, keeping the heaters active. The antifreeze heaters are present in the evaporator and on any recovery exchangers.

### Double set-point from digital input (accessory)

The double set-point allows two different working temperatures to be set: one for heating operation and one for cooling operation. Should a double set-point be required for both modes, it will be compulsory to provide the electronic thermostatic valve. The set-point temperatures must be specified when ordering. The set-point can be changed from keyboard or from digital input.

### RS485 Serial interface (accessory)

The growing diffusion of home automation systems and BMS (Building Management System) has led to the need to integrate all plant components under a single supervision. To meet this requirement, the unit can be equipped with a RS485 serial board with MODBUS protocol.

### Remote user terminal (accessory)

This accessory consists in a copy of the remote control panel, from where it is possible to fully configure the unit and display all its parameters. Access to the masks is via passwords that enable the different levels of modification.

### DHW 3-way valve (accessory)

**The accessory is not compatible with accessory tank (1PS e 2PS).**

It is an on/off type three-way valve that, combined with the automatic management of DHW function, allows the machine to manage two separate circuits for comfort and DHW production, automatically switching from one to the other based on the system need. The DHW 3-way valve must be installed in a technical compartment.

### Compensation of set-point depending on the outdoor temperature (accessory)

The controller allows modification of the unit set-point both in chiller operation and in heat pump, depending on the outdoor temperature. Compensation can be positive or negative: with positive compensation, upon outdoor air temperature increase, the summer temperature set-point will also increase, while with the negative compensation, upon air temperature increase, the temperature set-point decreases. Should the unit be used also for the production of DHW, the adjustment climate will not affect the DHW temperature set-point.

### Maximum and minimum voltage relay (accessory)

This device continuously controls the unit's power supply voltage, ensuring it is always within an admissible range. Should the voltage value be above or below that range, the device stops the unit to avoid damaging the electric motors. The same device also controls the phase sequence.

### Condensation/evaporation control with revolution regulator (standard)

The microprocessor control of the unit controls all operating parameters of the unit and continuously adjusts the speed of the fans through a revolution regulator, in order to optimise the operating conditions and the efficiency of the unit.

This adjustment also reduces the level of noise of the unit, in fact, the typical conditions in which the control will modulate the fan speed are the night-time and spring and autumn. This ensures that, whenever there is the opportunity, the machine decreases the fan speed to minimum and, therefore, noise.

### Water filter (accessory)

The water filter, located at the unit's water inlet, aims at preventing sludge, processing residues or other, from clogging the unit exchangers. It is compulsory that at the inlet of each circuit: source, utility and recovery, there is a filter with a 0.4 or 0.5 mm mesh. The absence of the filter automatically voids the warranty.

### Condensing drain pan (standard)

This accessory is compulsory when installed in a passageway. This is a drain pan used during winter mode (heat pump functions) to contain the water coming from the coil (also during defrost operating). This is standard on all products.

### Web supervision (accessory)

The units can be remotely managed in 2 different ways:

- > via web through LAN
- > via web through modem and telephone board (integrated in supervision)

The unit can be controlled totally through the connection.

The display possibilities are:

- > Inlet water temperature
- > Outlet water temperature
- > Air temperature
- > Condensation pressure
- > Evaporation pressure
- > Status of the unit
- > Presence of alarms
- > Compressor operation
- > Pump operation
- > Fan operation percentage

The modification possibilities are:

- > Power on and off of the unit
- > Switching of status: summer/winter or vice-versa
- > Reset of alarms. All unit alarms can be reset without physically reaching the installation
- > Modification of all set-points
- > Modification of climates

It is also possible to view a history of the operation of all variables (temperatures and pressures) detected by the control. This allows a view of the effective behaviour of the unit and of the system.

This function is essential to correctly set the system.

### Relay for outdoor pump management

If the unit is purchased without pumps, the customer is entrusted with the start and stop of the pump in accordance with the instructions in the installation, operation and maintenance manual. This accessory is necessary if the unit needs to control one or more external pumps. It allows control of an external pump with the same logic as a pump integrated in the unit. The accessory consists in the supply of a dry contact only usable for controlling the start and stop. The customer is responsible for the protection and power.

## RECOMMENDATIONS FOR INSTALLATION

The following instructions are intended to improve use of the heat pumps in systems and to prevent installation problems.

1. Heat Pumps are often combined with radiant heating systems. If the radiant system is in areas with control of the individual manifold head, it is compulsory to provide at least 20 litres of water per kW of heat yield of the unit, in condition of minimum water content, or with all heads closed. This is necessary because it is possible that a situation arises where almost all heads are closed and the heat pump works with an extremely reduced water volume. In this case, during defrosting, it is possible that the safety devices intervene due to excessive cooling of the water.
2. In the DWS version or with use of the "DHW automatic management" function, it is compulsory to work the recovery exchanger on technical water and not on pipe coil. In fact, the coupling of heat pumps with pipe coils has repeatedly proven to be a problem due to an incorrect dimensioning of the pipe coil surface.
3. In the DWS version or with use of the "DHW automatic management" function, installation of the temperature probe supplied is essential. The DHW storage tank must have a sump in its top part, long enough to reach almost the centre of the tank. The probe supplied with the unit must be inserted in the sump with conductive paste in order to allow the probe to accurately read the tank temperature. The incorrect reading of the temperature, caused by an unsuitable positioning, may lead to the intervention of the safety devices or blocking of the unit.
4. When using the "DHW automatic management" logic, it is necessary to use a three-way valve which, during switching, allows the water to flow and never presents the situation of blocked or reduced flow. The Installation, Operation and Maintenance Manual contains guidelines for selecting the valve.
5. The possible integration of water from the aqueduct must never be inserted in the inlet piping of the heat pump. The cold water made to abruptly enter the "hot" exchanger may cause the safety devices to intervene. If using a tank, the inlet of the water integration from the aqueduct must not directly flow in the inlet piping of the heat pump.
6. For the following reasons, it is not advisable to position the unit set-points on the operating limits:
  - a. Modification of the room temperature. The room temperature varies and may lead the unit to work outside the limits.
  - b. Presence of the water filter. The water filter must always be present at the unit's water inlet, under penalty of voiding the warranty. The filter will certainly get dirty over time. A dirty filter will increase load losses and consequently the flow rate. The DT increases and can go from 4/5° to 9°, 10°, causing the safety devices to intervene.
  - c. If the hydraulic circuit provides more areas, it may happen that when a circuit closes the pump has to operate on the remaining hydraulic circuit. This increases the load losses, decreases the flow rate and increases the DT with possible intervention of the safety devices.
  - d. In summer, the unit will be subject to solar radiation. Assuming air at 35°, the coil (in copper and aluminium, so very good conductor) will be at a very high temperature. When turning on the unit, even with fans at stand-still, the evaporation will be very high thus certainly producing the intervention of the high pressure switch.
  - e. Recirculation of air can create a micro-environment with a lower temperature of even 4/5°, leading the unit to operate outside the limits.
  - f. Clearances are very important, the upstream or downstream obstruction of the fan causes load losses that reduce the air flow rate. This reduction may cause the operating temperatures to drop. This drop may cause the unit to be outside the operating limits.
  - g. Air in the circuit. The air in the system, even if well-vented, creates a heat exchange coefficient loss with possible consequential intervention of the high pressure safety devices.



7. Use of unit to dry the screed. When building a house large amounts of water are used for the mortar, plaster, screed, which then evaporate from the building very slowly. Also, rain may significantly increase the humidity content of the construction. Due to the high humidity content in the whole building, during the first two heating periods, the heat requirement of the building is much higher. The masonry work must be dried using special equipment. If the heat power of the heat pump was calculated to be sufficient for the home and drying takes place in the autumn or winter, we recommend installing an additional electric heater to compensate the higher heat requirement.
8. Starting the system with low outdoor temperatures. The safety devices may intervene when starting the system during winter, with the temperature of the system water particularly cold and outside the unit's operating limits. To bring the system up to speed, just reduce the heat load by isolating part of the system. When the temperature of the partial system water is within the operating limits, it will be possible to also connect the previously isolated part of the system.
9. During defrosting, the unit cools the system water in order to eliminate the ice in the coil. To eliminate any problem, it is appropriate to insert a storage of at least 20÷25 litres of water per thermal kW of the unit.

## ACOUSTIC ASPECTS FOR THE INSTALLATION

For proper unit installation, keep the following in mind:

- > Installation of the unit near walls or other creates reverberation phenomena that increase the input of noise in the environment, even by 16 dBA
- > Bear in mind the possible sensitive receptors when installing the unit; avoid installing units near bedrooms
- > Check the noise regulation of the municipality where the unit will be installed to verify its absolute and differential limit
- > Bear in mind that, regardless of the acoustic class of the territory (Italian Prime Ministerial Decree 14 November 1997), there is a differential day and night-time criterion
- > In the event of critical installations, contact a Competent Technician in Acoustics for a preliminary evaluation

### Italian Prime Ministerial Decree 14 November 1997

The Italian Prime Ministerial Decree 14/11/97, which entered into force on 1st January 1998, determines the limit values of the sound sources, in particular it sets:

- > **Emission limit values** maximum noise that can be emitted by a source;
- > **Input limit values** maximum noise that can be input by one or more sound sources in the house or in the external environment, divided into absolute and differential;
- > **Attention values** of noise that signal the presence of a potential risk to health or for the environment;
- > **Quality values** of noise to achieve as a target in the short-, medium- and long-term.

The Italian Prime Ministerial Decree 14/11/97, like the Italian Prime Ministerial Decree 1/3/91, sets the absolute input limits for the outdoor environment for all types of sources. The decree also defines the limit values of emissions to be understood as "emission levels for a specific source evaluated at the receiver". These values, with the exception of the transport infrastructures, must be complied with by all sound sources. The limit values are set by acoustically dividing the territory in six classes. In particular, it is very important to know the "differential criterion" present and described in the decree. It is this criterion that most technicians do not know and which is the most restrictive.

### DIFFERENTIAL CRITERION

The differential noise level is the difference between the ambient noise level (i.e. that present when the noise source causing the disturbance is in operation) and the residual noise level (i.e. background noise). The differential noise level must not exceed the following input differential limit values (art. 4, comma 1 of Italian Prime Ministerial Decree 14/11/97):

- > 5 dB(A) for the daytime period (from 6.00-to 22.00)
- > 3 dB(A) for the night-time period (from 22.00-to 6.00)

## ETHYLENE GLYCOL CORRECTIVE COEFFICIENTS

Correction factors for the presence of Ethylene Glycol

ETHYLENE GLYCOL % IN WEIGHT		5%	10%	15%	20%	25%	30%	35%	40%
Freezing temperature	°C	-2,0	-3,9	-6,5	-8,9	-11,8	-15,6	-19	-23,4
Safety temperature	°C	3,0	1,0	-1,0	-4,0	-6,0	-10,0	-14,0	-19,0
Cooling Power Coefficient	-	0,995	0,990	0,985	0,981	0,977	0,974	0,971	0,968
Absorbed Power Coefficient	-	0,997	0,993	0,990	0,988	0,986	0,984	0,982	0,981
Mass flow rate coefficient	-	1,003	1,010	1,020	1,033	1,050	1,072	1,095	1,124
Load losses coefficient	-	1,029	1,060	1,090	1,118	1,149	1,182	1,211	1,243

The maximum admitted percentage of glycol per standard unit is 40%. For higher values, contact the sales department.

## PERFORMANCE ACCORDING TO EN14511 STANDARD

Data is provided according to the requirements of EN14511.

This set of rules redefines the method for calculating the performances of the heat pump chillers.

According to EN14511-2011, on the unit performance calculation, also add the power required to overcome the hydronic load losses of the circuit.

Method of calculation of the performance as follows.

$$P_{cooling, EN14511} = P_{cooling} - P_{abs, \Delta p}$$

$$P_{heating, EN14511} = P_{heating} + P_{abs, \Delta p}$$

$$P_{abs, EN14511} = P_{abs} + P_{abs, \Delta p}$$

$$EER_{EN14511} = \frac{P_{cooling, EN14511}}{P_{abs, EN14511}}$$

$$COP_{EN14511} = \frac{P_{heating, EN14511}}{P_{abs, EN14511}}$$

$$ESEER_{EN14511} = 0.003 \times EER_{100\%, EN14511} + 0.33 \times EER_{75\%, EN14511} + 0.41 \times EER_{50\%, EN14511} + 0.23 \times EER_{25\%, EN14511}$$

With:

$P_{cooling}$ : cooling power

$P_{heating}$ : heating power

$P_{cooling, EN14511}$ ,  $P_{heating, EN14511}$ ,  $EER_{EN14511}$ ,  $COP_{EN14511}$ ,  $ESEER_{EN14511}$ : data provided in compliance with EN14511

$P_{abs}$ : electric power absorbed (compressors and fan section) [ kW ]

$P_{abs, \Delta p}$ : electric power absorbed by the pump to overcome load losses of water in the heat exchanger

## TECHNICAL DATA

UNIT SIZE			40	45	55	65	75	90
<b>Heating (EN 14511 values)</b>								
Nominal heating capacity	(1), (7)	kW	33,6	40,3	51,0	59,2	71,7	84,9
Total Power input in heating mode	(1), (2), (7)	kW	10,7	12,6	15,3	16,3	22,0	25,3
COP	(1), (7)		3,22	3,30	3,41	3,44	3,08	3,13
Efficiency class			A	A	A	A	B	B
SCOP	(9)		3,42	3,45	3,58	4,02	3,62	3,75
Seasonal Efficiency class	(9)		A+	A+	A+	A++	A+	A+
<b>Heating (EN 14511 values)</b>								
Nominal heating capacity	(8)	kW	25,3	30,5	36,4	45,8	54,6	63,1
Total Power input in heating mode	(2), (8)	kW	12,5	14,3	16,7	19,8	25,9	29,4
COP	(8)		2,03	2,13	2,18	2,32	2,11	2,15
<b>Cooling (EN 14511 values)</b>								
Nominal cooling capacity	(3), (7)	kW	32,0	36,8	46,8	56,3	62,5	74,3
Total Power input in cooling mode	(3), (2), (7)	kW	10,7	13,5	17,0	18,8	22,6	27,1
EER	(3), (7)		2,98	2,72	2,76	3,00	2,76	2,74
ESEER			3,52	3,14	3,11	3,37	3,26	3,26
Efficiency class			B	C	C	B	C	C
<b>Compressor</b>								
Type			Reciprocating					
Quantity/Refrigerant circuits		n° / n°	1 / 1	1 / 1	1 / 1	1 / 1	1 / 1	1 / 1
Capacity steps		n°	2	2	2	2	2	2
Total oil charge		kg	4,0	4,5	4,8	4,8	4,8	4,8
Total refrigerant charge		kg	11,3	13,5	17,1	19,8	24,1	28,5
<b>Fans</b>								
Type - axial			Axial					
Quantity		n°	1	1	1	1	2	2
Air flow		m <sup>3</sup> /h	21.000	21.000	20.000	20.000	40.000	40.000
<b>Utility side exchanger</b>								
Type			Plate exchanger					
Water content		l	2,3	2,7	3,4	4,0	4,8	5,7
Water flow rate (A35/W7)	(3)	l/h	5.524	6.353	8.083	9.715	10.794	12.822
Pressure drop (A35/W7)	(3)	kPa	17	18	18	21	23	16
Water flow rate (A7/W75)	(8)	l/h	4.239	5.245	5.721	6.932	8.409	9.527
Pressure drop (A7/W75)	(8)	kPa	9	10	8	10	11	7
Water flow rate (A7/W45)	(1)	l/h	5.840	6.954	8.803	10.212	12.456	14.682
Pressure drop (A7/W45)	(1)	kPa	19	21	21	24	31	21
<b>Hydraulic module</b>								
Available pump pressure			P1	P1	P1	P1	P2	P2
Nominal Power input of pump		kW	1,1	1,1	1,1	1,1	2,5	2,5
Available pump pressure (A35/W7)	(3)	kPa	184	181	177	168	192	196
Available pump pressure (A7/W45)	(1)	kPa	181	176	171	164	182	186
Storage tank capacity		l	-	-	-	-	200	200
Expansion vessel		l	-	-	-	-	18	18
<b>Hydraulic connection</b>								
Connection			1" 1/2	1" 1/2	1" 1/2	1" 1/2	2"	2"
<b>Sound level STD version</b>								
Sound power value	(4), (6)	dB(A)	83	83	84	85	86	86
Sound pressure value	(5), (6)	dB(A)	55	55	56	57	58	58
<b>Sound level LN version</b>								
Sound power value	(4), (6)	dB(A)	81	81	82	83	84	84
Sound pressure value	(5), (6)	dB(A)	53	53	54	55	56	56
<b>Basic unit size and weights</b>								
Width		mm	1.408	1.408	1.408	1.408	3.508	3.508
Depth		mm	1.208	1.208	1.208	1.208	1.208	1.208
Height		mm	2.390	2.390	2.390	2.390	1.912	1.912
Delivery weight		kg	585	592	630	648	1.017	1.142
Operating weight		kg	590	597	637	656	1.027	1.152

- (1) External air temperature 7°C BS, 6°C BU, Inlet-outlet water 40-45 °C  
(2) Total power input is sum of compressors and fans power input and pump, according with EN 14511  
(3) External air temperature 35°C, Inlet-outlet water 12-7°C.  
(4) Sound power level calculate in compliance with ISO 3744  
(5) Sound pressure level calculate in compliance with ISO 3744  
(6) External air temperature 35°C, Inlet-outlet water 12-7°C.  
(7) Values calculate in compliance with EN 14511  
(8) External air temperature 7°C BS, 6°C BU, Inlet-outlet water 70-75 °C  
(9) according to European Regulation n° 813/2013  
This datasheet gives the characteristic data of the basic and standard versions of the series; for details refer to the specific documentation

## TECHNICAL DATA

UNIT SIZE			70	85	105	125	145	180	200	235
<b>Heating (EN 14511 values)</b>										
Nominal heating capacity	(1), (7)	kW	68,8	81,5	103,8	120,1	143,0	171,2	202,3	234,4
Total Power input in heating mode	(1), (2), (7)	kW	21,0	25,7	32,0	32,9	42,3	50,6	61,9	71,4
COP	(1), (7)		3,33	3,24	3,29	3,31	3,14	3,24	3,29	3,31
Efficiency class			A	A	A	A	B	A	A	A
SCOP	(9)		3,50	3,40	3,48	4,00	3,74	3,78	3,63	3,63
Seasonal Efficiency class	(9)		A+	A+	A+	A++	A+	A+	A+	A+
<b>Heating (EN 14511 values)</b>										
Nominal heating capacity	(8)	kW	51,8	61,0	74,2	93,0	110,1	128,2	150,6	182,6
Total Power input in heating mode	(2), (8)	kW	24,4	29,1	35,1	40,1	50,7	59,5	70,8	86,7
COP	(8)		2,12	2,09	2,11	2,32	2,17	2,15	2,13	2,11
<b>Cooling (EN 14511 values)</b>										
Nominal cooling capacity	(3), (7)	kW	61,4	71,3	90,6	100,7	120,9	145,2	173,8	201,1
Total Power input in cooling mode	(3), (2), (7)	kW	21,4	25,9	32,3	34,6	44,6	52,3	65,2	78,0
EER	(3), (7)		2,87	2,75	2,80	2,91	2,71	2,78	2,66	2,58
ESEER			3,22	3,12	3,17	3,29	3,17	3,17	3,06	3,00
Efficiency class			C	C	C	B	C	C	D	D
<b>Compressor</b>										
Type			Reciprocating							
Quantity/Refrigerant circuits		n° / n°	2 / 2	2 / 2	2 / 2	2 / 2	2 / 2	2 / 2	2 / 2	2 / 2
Capacity steps		n°	4	4	4	4	4	4	4	4
Total oil charge		kg	8,0	9,0	9,5	9,5	9,5	9,5	14,8	10,0
Total refrigerant charge		kg	23,1	27,5	34,8	40,4	48,3	56,9	67,2	77,9
<b>Fans</b>										
Type - axial			Axial							
Quantity		n°	2	2	2	2	3	3	4	4
Air flow		m <sup>3</sup> /h	40.000	40.000	40.000	40.000	60.000	60.000	80.000	80.000
<b>Utility side exchanger</b>										
Type			Plate exchanger							
Water content		l	4,6	5,5	7,0	8,1	9,7	11,4	13,4	15,6
Water flow rate (A35/W7)	(3)	l/h	10.581	12.291	15.630	17.352	20.843	25.039	29.957	34.669
Pressure drop (A35/W7)	(3)	kPa	13	16	15	14	15	19	20	20
Water flow rate (A7/W75)	(8)	l/h	8.478	10.490	11.443	13.864	16.819	21.685	24.583	29.848
Pressure drop (A7/W75)	(8)	kPa	7	9	6	6	7	10	10	11
Water flow rate (A7/W45)	(1)	l/h	11.914	14.187	17.958	20.832	24.912	29.363	34.686	40.189
Pressure drop (A7/W45)	(1)	kPa	16	22	20	20	22	26	26	28
<b>Hydraulic module</b>										
Available pump pressure			P2	P2	P2	P2	P3	P3	P3	P3
Nominal Power input of pump		kW	2,5	2,5	2,5	2,5	3,0	3,0	3,0	3,0
Available pump pressure (A35/W7)	(3)	kPa	202	197	189	184	190	182	174	165
Available pump pressure (A7/W45)	(1)	kPa	197	187	176	164	179	169	159	145
Storage tank capacity		l	200	200	200	200	400	400	400	400
Expansion vessel		l	18	18	18	18	18	18	18	18
<b>Hydraulic connection</b>										
Connection			2" 1/2	2" 1/2	2" 1/2	2" 1/2	2" 1/2	2" 1/2	3"	3"
<b>Sound level</b>										
Sound power value	(4), (6)	dB(A)	87	87	88	88	89	89	93	93
Sound pressure value	(5), (6)	dB(A)	59	59	60	60	61	61	65	65
<b>Sound level</b>										
Sound power value	(4), (6)	dB(A)	85	85	86	86	87	87	91	91
Sound pressure value	(5), (6)	dB(A)	57	57	58	58	59	59	63	63
<b>Basic unit size and weights</b>										
Width		mm	3.508	3.508	3.508	3.508	4.608	4.608	5.330	5.330
Depth		mm	1.208	1.208	1.208	1.208	1.208	1.208	1.208	1.208
Height		mm	1.912	1.912	1.912	1.912	1.912	1.912	1.912	1.912
Delivery weight		kg	1.323	1.505	1.539	1.541	1.744	1.759	2.099	2.268
Operating weight		kg	1.334	1.516	1.550	1.552	1.758	1.773	2.114	2.284

- (1) External air temperature 7°C BS, 6°C BU, Inlet-outlet water 40-45 °C
- (2) Total power input is sum of compressors and fans power input and pump, according with EN 14511
- (3) External air temperature 35°C, Inlet-outlet water 12-7°C.
- (4) Sound power level calculate in compliance with ISO 3744
- (5) Sound pressure level calculate in compliance with ISO 3744
- (6) External air temperature 35°C, Inlet-outlet water 12-7°C.
- (7) Values calculate in compliance with EN 14511
- (8) External air temperature 7°C BS, 6°C BU, Inlet-outlet water 70-75 °C
- (9) according to European Regulation n° 813/2013

This datasheet gives the characteristic data of the basic and standard versions of the series; for details refer to the specific documentation

## ELECTRICAL DATA

UNIT SIZE			40	45	55	65	75	90
Maximum absorbed power	(1),(3)	kW	22,6 (23,7)	26,6 (27,7)	31,6 (32,7)	37,6 (38,7)	45,2 (47,7)	54,2 (56,7)
Maximum starting current	(2),(3)	A	41,1 (43,8)	47,9 (50,6)	57,1 (59,8)	68,3 (71,0)	81,7 (86,2)	104,0 (108,5)
Full load current	(4)	A	104,8 (62,9)	132,8 (79,7)	172,8 (103,7)	172,8 (103,7)	234,6 (140,8)	241,6 (145,0)
Fan motor nominal power		n° x kW	1 x 1,6	1 x 1,6	1 x 1,6	1 x 1,6	2 x 1,6	2 x 1,6
Fan motor nominal absorbed current		n° x A	1 x 3,9	1 x 3,9	1 x 3,9	1 x 3,9	2 x 3,9	2 x 3,9
Pump motor nominal power		kW	1,10	1,10	1,10	1,10	2,45	2,45
Pump motor nominal current		A	2,70	2,70	2,70	2,70	4,53	4,53
Power supply		V/ph/Hz	400/3N~/50 ±5%					
Power supply		V/ph/Hz	230/1~/50 ±5%					

UNIT SIZE			70	85	105	125	145	180	200	235
Maximum absorbed power	(1),(3)	kW	45,2 (47,7)	53,2 (55,7)	63,2 (65,7)	75,2 (77,7)	88,8 (91,8)	106,8 (109,8)	198,4 (201,4)	162,4 (165,4)
Maximum starting current	(2),(3)	A	82,2 (86,7)	95,8 (100,3)	114,2 (118,7)	136,6 (141,1)	159,5 (165,9)	204,1 (210,5)	358,0 (364,4)	293,6 (300,0)
Full load current	(4)	A	142,0 (85,2)	176,8 (106,1)	226,0 (135,6)	237,2 (142,3)	304,6 (182,8)	333,9 (200,3)	481,0 (288,6)	555,6 (333,4)
Fan motor nominal power		n° x kW	2 x 1,6	2 x 1,6	2 x 1,6	2 x 1,6	3 x 1,6	3 x 1,6	4 x 1,6	4 x 1,6
Fan motor nominal absorbed current		n° x A	2 x 3,9	2 x 3,9	2 x 3,9	2 x 3,9	3 x 3,9	3 x 3,9	4 x 3,9	4 x 3,9
Pump motor nominal power		kW	2,45	2,45	2,45	2,45	3,00	3,00	3,00	3,00
Pump motor nominal current		A	4,53	4,53	4,53	4,53	6,35	6,35	6,35	6,35
Power supply		V/ph/Hz	400/3N~/50 ±5%							
Power supply		V/ph/Hz	230/1~/50 ±5%							

### Notes

- > Voltage unbalance: max 2%
- > "The standard power supply voltage (see specific wiring diagram) must not vary by more than ±5%"
- > Electric data refers to standard unit. Data may change based on the installed accessories

(1) Mains power supply to allow unit operation  
(2) Maximum current before safety cut-outs stop the unit. This value is never exceeded and must be used to size the electrical supply cables and relevant safety devices (refer to electrical wiring diagram supplied with the unit).  
(3) values in brackets refer to ST version units (units with storage tank and pumps or units with exclusively pumps)  
(4) Maximum starting current calculated considering the bigger size compressor starting current plus the maximum absorbed power of the other electrical devices (pumps, fans)

## OPERATION IN COOLING

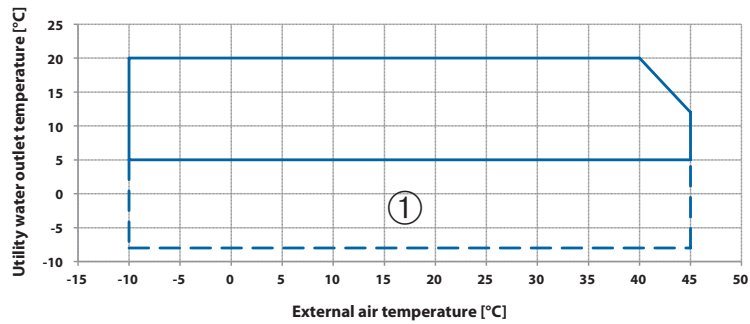

### Notes

- > The thermal head to the utility side exchange must be between 3°C and 6°C
- > ① : in this area the unit can only work with evaporator side glycoled water
- > Operating outside the operating limits may cause the safety devices to intervene or serious malfunctions
- > Within the operating limits, the fan section may be subject to modulation

## HEATING AND RECOVERY OPERATION HT VERSION

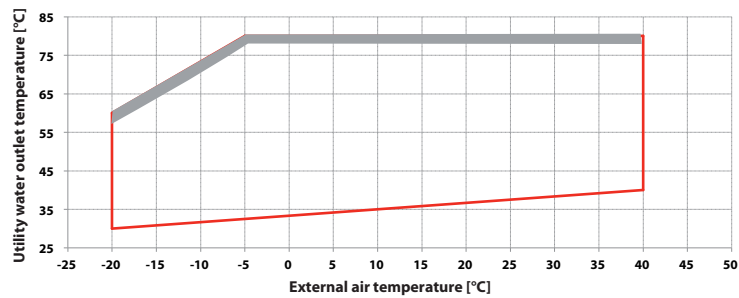

### Notes

- > The thermal head to the utility side exchange must be between 3°C and 6°C
- > Operating outside the operating limits may cause the safety devices to intervene or serious malfunctions
- > The temperature of inlet water to utility side exchanger cannot be less than 25°C
- > ■ The unit can work within this field but NOT CONTINUOUSLY
- > Within the operating limits, the fan section may be subject to modulation
- > Within the operating limits, to limit the flow temperature, the unit may be subject to choking

**PRESSURE DROP DIAGRAM**

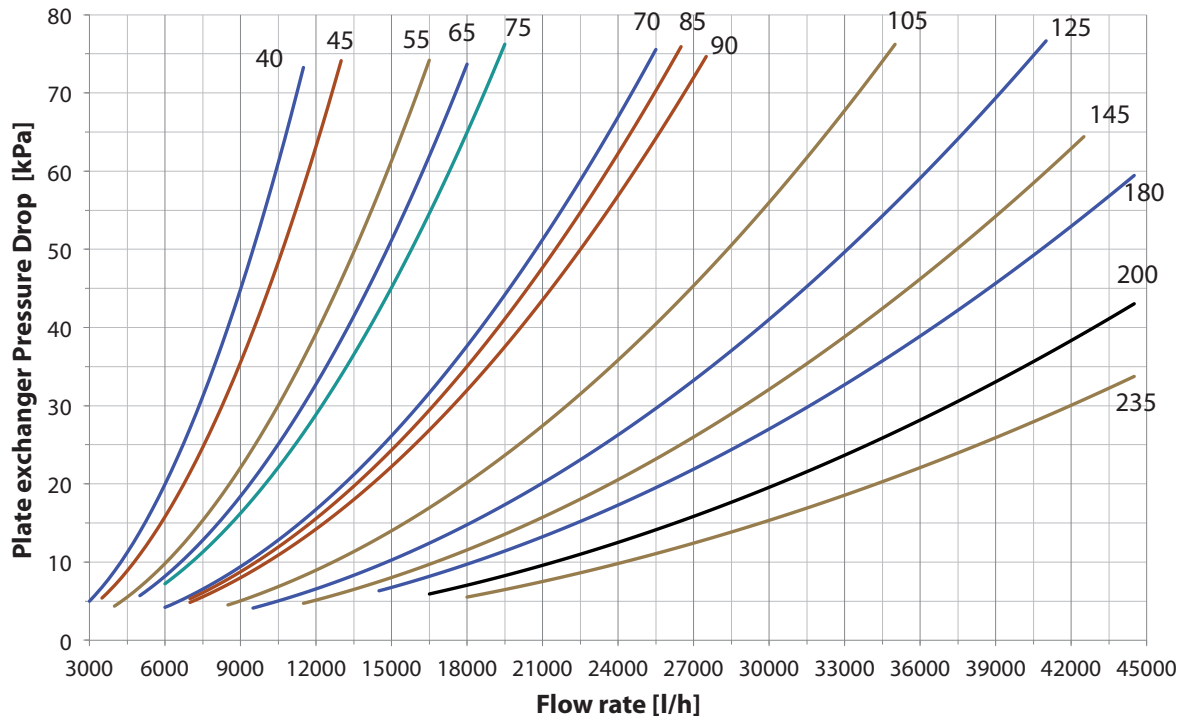

**AVAILABLE PRESSURE DIAGRAM**

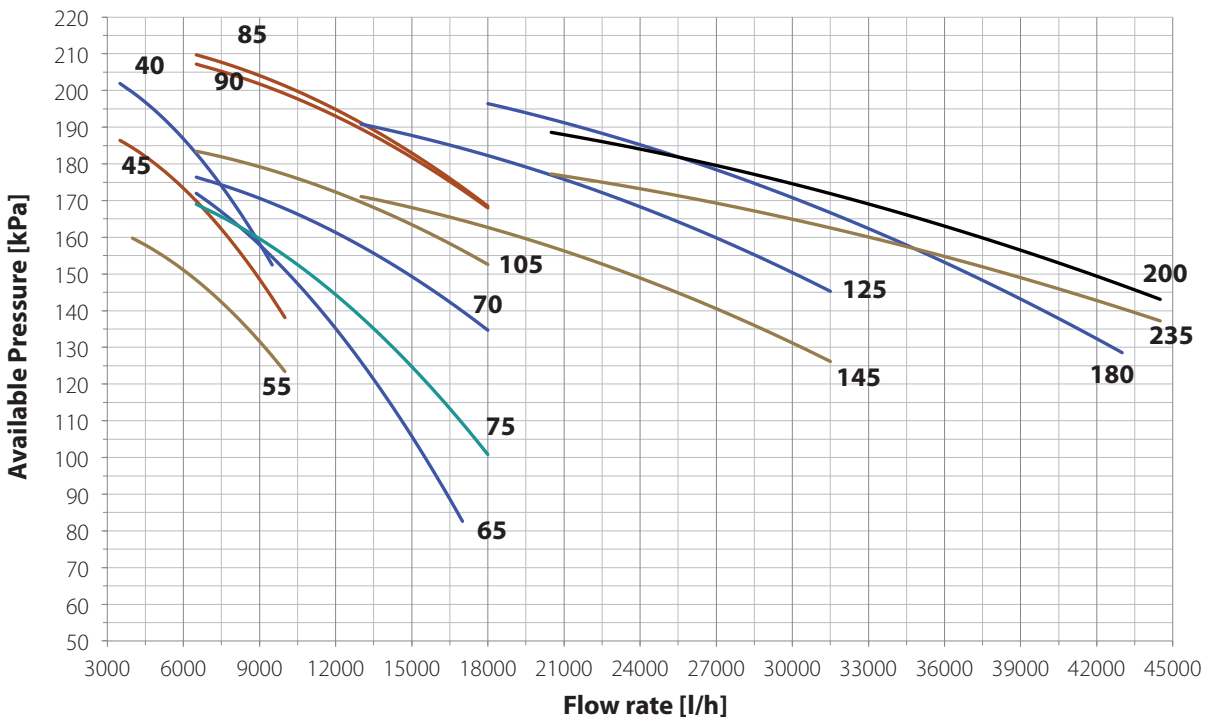

## COOLING CAPACITY

	To [°C]	Ta [°C]														
		25			30			35			40			45		
		KWF	kWe	EER	KWF	kWe	EER	KWF	kWe	EER	KWF	kWe	EER	KWF	kWe	EER
40	10/5	33,2	9,3	3,6	32,6	10,1	3,2	30,6	10,4	2,9	28,7	10,9	2,6	27,0	11,3	2,4
	11/6	35,6	9,8	3,6	33,2	10,2	3,3	31,6	10,7	3,0	29,6	11,1	2,7	27,8	11,5	2,4
	12/7	35,6	9,7	3,7	35,3	10,5	3,4	32,0	10,7	3,0	31,6	11,5	2,7	28,9	11,8	2,5
	13/8	36,6	9,8	3,7	35,3	10,5	3,4	33,9	11,0	3,1	31,9	11,6	2,8	28,9	11,8	2,4
	14/9	38,2	10,1	3,8	36,5	10,7	3,4	34,6	11,2	3,1	32,5	11,8	2,8	30,7	12,3	2,5
	15/10	38,6	10,3	3,8	37,5	10,8	3,5	36,3	11,6	3,1	33,7	12,0	2,8	31,9	12,5	2,5
	17/12	41,8	10,6	3,9	39,8	11,3	3,5	38,4	12,0	3,2	35,9	12,5	2,9	33,1	12,8	2,6
	19/14	44,4	11,0	4,0	42,9	11,8	3,6	40,4	12,4	3,3	38,4	12,9	3,0	34,8	13,3	2,6
	21/16	45,9	11,2	4,1	45,9	12,2	3,8	43,4	12,8	3,4	40,6	13,5	3,0	37,7	13,9	2,7
	23/18	49,7	11,6	4,3	47,8	12,4	3,9	47,3	13,4	3,5	44,0	14,1	3,1	-	-	-
45	10/5	39,9	12,1	3,3	37,0	12,5	3,0	34,6	13,0	2,7	32,8	13,6	2,4	30,5	13,9	2,2
	11/6	40,2	12,3	3,3	37,5	12,8	2,9	35,9	13,4	2,7	33,9	13,7	2,5	31,1	14,0	2,2
	12/7	41,3	12,4	3,3	40,8	13,3	3,1	36,8	13,5	2,7	34,4	14,0	2,5	32,4	14,5	2,2
	13/8	43,6	12,8	3,4	40,6	13,3	3,1	38,2	13,8	2,8	36,5	14,4	2,5	33,2	14,5	2,3
	14/9	44,5	12,9	3,4	42,7	13,6	3,1	41,2	14,4	2,9	37,2	14,6	2,6	34,3	14,9	2,3
	15/10	46,1	13,2	3,5	43,8	13,8	3,2	41,6	14,6	2,8	38,3	14,8	2,6	36,1	15,4	2,3
	17/12	49,9	13,9	3,6	45,8	14,1	3,2	43,9	14,9	3,0	40,4	15,4	2,6	37,5	15,8	2,4
	19/14	51,4	14,3	3,6	48,8	14,8	3,3	46,8	15,4	3,0	43,4	15,9	2,7	39,6	16,4	2,4
	21/16	54,7	14,7	3,7	52,6	15,3	3,4	49,2	16,0	3,1	45,4	16,5	2,8	42,4	17,1	2,5
	23/18	58,0	15,2	3,8	54,9	15,8	3,5	52,2	16,5	3,2	48,6	17,3	2,8	-	-	-
55	10/5	49,0	15,4	3,2	45,4	15,8	2,9	44,1	16,6	2,7	40,6	16,8	2,4	37,1	17,0	2,2
	11/6	50,4	15,6	3,2	48,1	16,1	3,0	45,7	16,9	2,7	41,6	17,0	2,4	38,3	17,4	2,2
	12/7	52,1	16,0	3,3	50,1	16,5	3,0	46,8	17,0	2,8	44,1	17,5	2,5	40,1	17,9	2,2
	13/8	54,0	16,3	3,3	50,8	16,7	3,0	48,5	17,4	2,8	45,4	17,9	2,5	41,1	18,1	2,3
	14/9	55,5	16,6	3,4	52,6	17,0	3,1	50,2	17,8	2,8	45,8	18,0	2,5	42,0	18,3	2,3
	15/10	57,7	16,9	3,4	56,1	17,8	3,2	51,1	17,8	2,9	47,6	18,4	2,6	44,1	19,0	2,3
	17/12	62,6	17,6	3,6	58,2	18,0	3,2	54,2	18,4	2,9	50,6	19,1	2,6	46,9	19,6	2,4
	19/14	64,8	18,0	3,6	60,5	18,4	3,3	58,1	19,3	3,0	53,9	19,9	2,7	49,5	20,3	2,4
	21/16	70,0	18,7	3,7	66,2	19,4	3,4	61,1	19,9	3,1	57,2	20,6	2,8	52,6	21,1	2,5
	23/18	73,4	19,3	3,8	69,1	19,8	3,5	65,1	20,7	3,1	60,0	21,2	2,8	-	-	-
65	10/5	56,1	16,2	3,5	54,2	17,0	3,2	50,7	17,7	2,9	49,4	18,5	2,7	45,2	19,2	2,4
	11/6	58,5	16,7	3,5	54,9	17,4	3,2	52,8	18,1	2,9	48,5	18,5	2,6	45,7	19,2	2,4
	12/7	61,1	17,2	3,5	58,1	17,8	3,3	56,3	18,8	3,0	51,1	19,1	2,7	46,8	19,6	2,4
	13/8	62,3	17,4	3,6	59,5	18,0	3,3	56,0	18,8	3,0	53,3	20,0	2,7	50,0	20,5	2,4
	14/9	65,7	18,0	3,6	61,1	18,5	3,3	57,7	19,1	3,0	53,4	19,8	2,7	50,8	20,7	2,5
	15/10	65,5	18,0	3,6	62,7	18,8	3,3	59,8	19,7	3,0	56,0	20,6	2,7	51,5	21,1	2,4
	17/12	69,7	18,7	3,7	67,9	20,1	3,4	62,7	20,4	3,1	58,8	21,3	2,8	54,1	21,9	2,5
	19/14	75,6	19,8	3,8	71,8	20,6	3,5	66,6	21,5	3,1	62,2	22,3	2,8	58,1	23,2	2,5
	21/16	78,1	20,2	3,9	76,0	21,7	3,5	71,1	22,6	3,1	65,5	23,3	2,8	60,9	24,1	2,5
	23/18	82,9	21,4	3,9	77,9	21,9	3,6	73,4	23,1	3,2	68,7	24,6	2,8	-	-	-



	To [°C]	Ta [°C]														
		25			30			35			40			45		
		KWF	kWe	EER	KWF	kWe	EER	KWF	kWe	EER	KWF	kWe	EER	KWF	kWe	EER
75	10/5	63,6	19,4	3,3	63,4	20,9	3,0	59,4	21,9	2,7	54,8	22,5	2,4	51,1	23,3	2,2
	11/6	65,7	19,7	3,3	63,1	20,9	3,0	59,8	22,0	2,7	57,9	23,4	2,5	53,2	24,0	2,2
	12/7	67,5	20,1	3,4	66,9	21,5	3,1	62,6	22,6	2,8	58,5	23,4	2,5	53,4	24,1	2,2
	13/8	70,0	20,5	3,4	67,0	21,7	3,1	64,5	23,1	2,8	59,6	23,9	2,5	56,2	24,6	2,3
	14/9	71,8	20,8	3,5	69,5	22,1	3,1	66,1	23,4	2,8	61,4	24,2	2,5	58,4	25,3	2,3
	15/10	74,8	21,2	3,5	74,5	23,0	3,2	68,4	23,7	2,9	63,1	24,8	2,5	59,4	25,7	2,3
	17/12	79,8	22,0	3,6	75,5	23,5	3,2	75,3	25,2	3,0	68,5	25,7	2,7	62,6	26,7	2,3
	19/14	84,0	22,6	3,7	80,1	23,9	3,4	76,3	25,4	3,0	71,8	26,8	2,7	67,1	27,9	2,4
	21/16	88,7	23,3	3,8	85,1	24,9	3,4	80,2	26,1	3,1	76,2	27,7	2,7	71,8	29,0	2,5
	23/18	92,6	23,8	3,9	89,8	25,6	3,5	85,3	27,2	3,1	80,6	28,7	2,8	-	-	-
90	10/5	77,6	23,5	3,3	75,1	24,7	3,0	70,5	25,9	2,7	65,8	26,9	2,4	60,3	27,5	2,2
	11/6	80,8	24,0	3,4	76,7	25,2	3,0	74,0	26,7	2,8	68,4	27,5	2,5	61,9	27,8	2,2
	12/7	83,0	24,5	3,4	79,3	25,7	3,1	74,3	27,1	2,7	69,3	27,8	2,5	64,3	28,6	2,2
	13/8	86,9	25,1	3,5	82,4	26,2	3,1	77,3	27,2	2,8	72,3	28,8	2,5	66,3	29,3	2,3
	14/9	88,6	25,3	3,5	84,7	26,7	3,2	79,7	28,1	2,8	73,3	29,1	2,5	68,6	29,9	2,3
	15/10	95,0	26,4	3,6	86,3	27,0	3,2	82,8	28,7	2,9	75,9	29,5	2,6	72,5	31,3	2,3
	17/12	95,8	26,5	3,6	94,0	28,4	3,3	87,1	29,6	2,9	81,2	30,7	2,6	75,2	31,8	2,4
	19/14	104,0	27,9	3,7	98,5	29,3	3,4	93,4	30,8	3,0	87,0	32,0	2,7	79,4	33,0	2,4
	21/16	110,2	29,0	3,8	102,8	30,1	3,4	97,1	31,6	3,1	90,4	33,0	2,7	86,2	34,9	2,5
	23/18	114,6	29,7	3,9	110,3	31,3	3,5	104,3	32,9	3,2	95,7	34,1	2,8	-	-	-
70	10/5	61,9	18,8	3,3	58,5	19,5	3,0	57,7	20,8	2,8	53,6	21,7	2,5	49,5	21,9	2,3
	11/6	62,6	18,6	3,4	61,3	19,7	3,1	58,8	21,2	2,8	56,3	22,3	2,5	51,9	22,8	2,3
	12/7	65,0	19,2	3,4	63,6	20,5	3,1	61,3	21,4	2,9	56,1	22,3	2,5	54,8	23,4	2,3
	13/8	67,3	19,5	3,4	65,2	20,7	3,1	62,7	21,7	2,9	59,3	23,0	2,6	56,1	23,6	2,4
	14/9	69,4	19,9	3,5	67,6	21,2	3,2	63,6	22,1	2,9	61,0	23,5	2,6	55,6	23,8	2,3
	15/10	71,2	20,2	3,5	69,0	21,5	3,2	66,1	22,6	2,9	62,1	23,7	2,6	58,9	24,7	2,4
	17/12	75,7	20,9	3,6	73,3	21,9	3,3	68,5	23,1	3,0	67,4	24,5	2,7	62,3	25,5	2,4
	19/14	81,1	21,7	3,7	77,4	22,8	3,4	73,6	23,9	3,1	69,5	25,4	2,7	65,8	26,4	2,5
	21/16	85,5	22,3	3,8	81,7	23,7	3,4	78,8	25,0	3,2	71,9	25,9	2,8	68,8	27,2	2,5
	23/18	89,2	23,1	3,9	84,9	24,1	3,5	82,7	25,7	3,2	77,8	27,1	2,9	-	-	-
85	10/5	74,9	22,9	3,3	71,0	23,9	3,0	67,4	24,8	2,7	63,3	25,6	2,5	59,3	26,5	2,2
	11/6	76,7	23,3	3,3	74,5	24,7	3,0	69,8	25,3	2,8	64,8	26,2	2,5	60,3	26,9	2,2
	12/7	79,1	23,7	3,3	75,3	24,5	3,1	71,3	25,9	2,8	68,3	26,8	2,6	63,1	27,4	2,3
	13/8	83,2	24,3	3,4	79,1	25,4	3,1	74,0	26,4	2,8	70,2	27,4	2,6	64,7	28,0	2,3
	14/9	84,6	24,9	3,4	82,2	25,8	3,2	77,6	26,9	2,9	70,2	27,6	2,5	66,1	28,0	2,4
	15/10	87,6	25,0	3,5	83,3	26,1	3,2	79,0	27,1	2,9	74,3	28,3	2,6	70,5	29,7	2,4
	17/12	91,8	25,8	3,6	87,0	27,0	3,2	82,8	28,0	3,0	78,9	29,4	2,7	72,1	30,1	2,4
	19/14	98,9	26,8	3,7	92,9	27,9	3,3	88,8	29,2	3,0	83,0	30,5	2,7	77,2	31,5	2,5
	21/16	102,6	27,5	3,7	100,0	29,0	3,5	94,5	30,3	3,1	87,6	31,4	2,8	81,9	32,7	2,5
	23/18	107,9	28,3	3,8	102,5	29,5	3,5	98,9	31,3	3,2	91,3	32,4	2,8	-	-	-
105	10/5	93,9	28,9	3,3	88,4	29,8	3,0	83,4	30,5	2,7	80,9	32,3	2,5	71,8	32,2	2,2
	11/6	97,0	29,5	3,3	92,5	30,3	3,0	86,5	31,4	2,8	84,8	33,0	2,6	75,2	32,8	2,3
	12/7	99,7	29,8	3,3	94,4	31,0	3,1	90,6	32,3	2,8	84,2	33,0	2,6	76,4	33,6	2,3
	13/8	103,3	30,3	3,4	97,8	31,6	3,1	95,5	32,9	2,9	89,5	34,3	2,6	81,1	35,2	2,3
	14/9	106,2	31,0	3,4	101,0	32,1	3,1	96,1	33,5	2,9	88,9	34,3	2,6	81,5	34,9	2,3
	15/10	110,4	31,6	3,5	104,3	32,6	3,2	101,4	34,3	3,0	92,7	35,0	2,6	85,8	36,0	2,4
	17/12	117,5	32,7	3,6	112,6	34,0	3,3	105,7	35,3	3,0	95,2	35,9	2,7	91,1	37,2	2,4
	19/14	124,1	33,6	3,7	117,6	34,9	3,4	114,5	36,6	3,1	107,5	37,9	2,8	96,4	38,6	2,5
	21/16	131,0	34,8	3,8	129,1	36,6	3,5	118,2	37,7	3,1	110,3	38,9	2,8	100,3	39,6	2,5
	23/18	137,6	35,9	3,8	132,9	37,4	3,6	124,4	38,6	3,2	115,8	40,0	2,9	-	-	-

To: evaporator in/out water temperature [°C]  
Ta: External air temperature (Dry Bulb) [°C]  
KWF : cooling capacity [kW] (in conformity of EN14511)  
kWe: electrical power input in kW (in conformity of EN14511)

	To [°C]	Ta [°C]														
		25			30			35			40			45		
		KWF	kWe	EER	KWF	kWe	EER	KWF	kWe	EER	KWF	kWe	EER	KWF	kWe	EER
125	10/5	104,3	30,5	3,4	99,7	31,8	3,1	94,8	32,8	2,9	89,2	34,3	2,6	81,7	35,1	2,3
	11/6	107,8	31,1	3,5	103,5	32,5	3,2	97,7	33,8	2,9	91,8	35,0	2,6	84,6	36,0	2,3
	12/7	111,1	31,8	3,5	106,8	33,3	3,2	100,7	34,6	2,9	93,4	35,6	2,6	87,3	36,7	2,4
	13/8	113,0	32,3	3,5	108,1	33,6	3,2	104,7	35,4	3,0	97,0	36,5	2,7	90,9	38,2	2,4
	14/9	117,9	33,2	3,6	113,7	34,7	3,3	107,8	36,2	3,0	100,0	37,5	2,7	94,0	38,9	2,4
	15/10	126,0	34,7	3,6	116,8	35,3	3,3	111,2	36,9	3,0	103,7	38,4	2,7	95,7	39,5	2,4
	17/12	132,7	36,0	3,7	124,2	36,7	3,4	117,2	38,4	3,0	109,6	40,0	2,7	102,4	41,6	2,5
	19/14	140,0	37,5	3,7	130,5	38,2	3,4	124,0	40,2	3,1	116,0	41,8	2,8	107,0	43,2	2,5
	21/16	142,6	37,9	3,8	137,6	39,6	3,5	131,9	42,2	3,1	122,3	43,6	2,8	117,9	46,8	2,5
	23/18	155,9	40,4	3,9	148,7	42,1	3,5	136,3	43,3	3,1	127,6	45,4	2,8	-	-	-
145	10/5	124,3	39,2	3,2	118,9	40,7	2,9	113,3	43,1	2,6	104,9	44,4	2,4	98,6	45,3	2,2
	11/6	129,9	39,9	3,3	121,5	41,8	2,9	116,3	43,4	2,7	109,6	45,5	2,4	103,6	47,4	2,2
	12/7	133,0	40,7	3,3	126,7	42,9	3,0	120,2	44,9	2,7	113,5	46,3	2,5	106,0	47,9	2,2
	13/8	138,3	41,6	3,3	130,9	43,3	3,0	125,1	45,4	2,8	115,9	47,4	2,4	108,8	49,3	2,2
	14/9	142,3	42,4	3,4	135,4	44,4	3,0	128,3	46,6	2,8	122,5	48,5	2,5	112,3	50,1	2,2
	15/10	146,0	43,0	3,4	139,2	45,0	3,1	133,4	47,9	2,8	123,7	49,0	2,5	115,5	51,2	2,3
	17/12	154,5	44,5	3,5	148,3	47,0	3,2	140,2	49,3	2,8	131,6	51,4	2,6	121,7	53,1	2,3
	19/14	164,5	46,1	3,6	157,8	48,8	3,2	149,4	51,0	2,9	138,7	53,2	2,6	129,2	55,4	2,3
	21/16	175,6	48,3	3,6	164,6	50,3	3,3	155,4	52,8	2,9	145,7	55,1	2,6	136,3	57,5	2,4
	23/18	181,7	49,3	3,7	172,6	51,9	3,3	164,1	54,6	3,0	154,2	57,6	2,7	-	-	-
180	10/5	145,5	45,7	3,2	143,2	48,8	2,9	133,7	50,4	2,7	125,5	52,2	2,4	117,6	54,1	2,2
	11/6	152,0	47,2	3,2	144,2	48,9	2,9	137,9	50,9	2,7	129,2	53,4	2,4	122,7	55,7	2,2
	12/7	157,4	48,1	3,3	150,1	50,1	3,0	145,2	52,3	2,8	134,3	54,6	2,5	126,5	56,9	2,2
	13/8	161,5	48,7	3,3	154,3	51,5	3,0	146,6	53,1	2,8	136,2	55,3	2,5	128,2	57,5	2,2
	14/9	167,5	50,0	3,4	160,3	52,2	3,1	153,8	54,5	2,8	142,5	56,3	2,5	134,0	59,2	2,3
	15/10	170,3	50,9	3,3	164,8	53,1	3,1	156,5	55,5	2,8	147,6	58,2	2,5	134,0	59,5	2,3
	17/12	179,6	52,3	3,4	174,3	54,7	3,2	165,8	57,6	2,9	153,8	59,9	2,6	142,4	61,9	2,3
	19/14	193,2	54,6	3,5	182,2	56,6	3,2	173,9	59,3	2,9	164,8	62,6	2,6	150,8	64,5	2,3
	21/16	197,2	55,7	3,5	192,5	58,6	3,3	181,1	61,3	3,0	173,0	64,6	2,7	160,3	67,1	2,4
	23/18	216,0	58,7	3,7	200,3	60,3	3,3	195,7	64,6	3,0	177,4	66,1	2,7	-	-	-
200	10/5	180,5	57,5	3,1	169,6	59,7	2,8	160,8	62,3	2,6	149,7	64,2	2,3	137,5	65,5	2,1
	11/6	183,7	58,1	3,2	177,1	61,0	2,9	165,7	63,4	2,6	153,7	65,4	2,4	143,4	67,1	2,1
	12/7	190,2	59,4	3,2	182,4	62,2	2,9	173,8	65,2	2,7	163,5	67,8	2,4	148,6	68,4	2,2
	13/8	196,8	60,9	3,2	186,8	63,2	3,0	178,9	66,4	2,7	163,5	68,0	2,4	153,4	70,0	2,2
	14/9	204,2	62,2	3,3	194,5	64,8	3,0	182,7	67,1	2,7	171,1	69,6	2,5	157,0	71,3	2,2
	15/10	211,6	64,2	3,3	198,8	65,7	3,0	189,1	68,5	2,8	174,0	70,7	2,5	164,6	73,3	2,2
	17/12	223,8	65,9	3,4	209,5	67,7	3,1	199,3	71,2	2,8	185,7	73,6	2,5	170,6	75,3	2,3
	19/14	235,2	67,6	3,5	223,3	70,8	3,2	207,6	72,7	2,9	193,5	75,4	2,6	180,0	77,8	2,3
	21/16	250,2	70,1	3,6	236,3	74,3	3,2	219,1	75,7	2,9	206,3	78,5	2,6	192,5	81,3	2,4
	23/18	257,6	72,2	3,6	251,1	76,4	3,3	233,2	78,9	3,0	217,0	81,7	2,7	-	-	-
235	10/5	214,2	70,2	3,0	201,1	72,1	2,8	190,7	75,2	2,5	174,5	77,4	2,3	161,3	79,4	2,0
	11/6	218,5	71,0	3,1	207,6	73,6	2,8	192,7	76,0	2,5	179,0	78,7	2,3	165,8	81,2	2,0
	12/7	228,8	73,1	3,1	213,1	74,7	2,9	201,1	78,0	2,6	185,5	80,3	2,3	171,5	82,9	2,1
	13/8	236,5	75,4	3,1	220,3	76,7	2,9	207,6	80,1	2,6	192,1	82,3	2,3	178,7	85,2	2,1
	14/9	234,1	74,9	3,1	227,6	78,2	2,9	213,0	80,9	2,6	198,0	83,8	2,4	184,6	87,1	2,1
	15/10	250,2	77,1	3,2	233,2	79,4	2,9	218,6	82,9	2,6	205,1	86,0	2,4	188,8	88,2	2,1
	17/12	260,4	79,5	3,3	250,4	83,4	3,0	230,5	85,8	2,7	215,9	89,1	2,4	199,9	92,0	2,2
	19/14	274,0	82,2	3,3	260,5	86,1	3,0	245,7	90,5	2,7	226,8	92,8	2,4	209,9	95,7	2,2
	21/16	289,9	85,9	3,4	278,5	90,4	3,1	254,2	93,3	2,7	237,6	97,9	2,4	223,5	100,8	2,2
	23/18	305,4	88,4	3,5	285,0	92,2	3,1	270,9	97,7	2,8	251,0	101,3	2,5	-	-	-

To: evaporator in/out water temperature [°C]  
Ta: External air temperature (Dry Bulb) [°C]  
KWF : cooling capacity [kW] (in conformity of EN14511)  
kWe: electrical power input in kW (in conformity of EN14511)









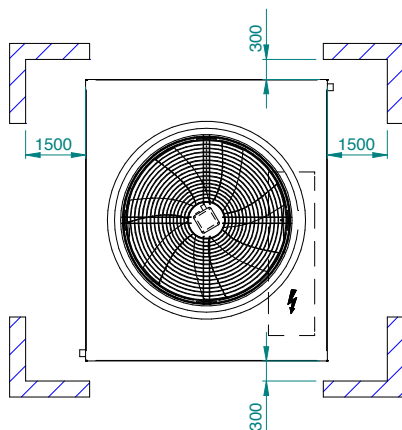
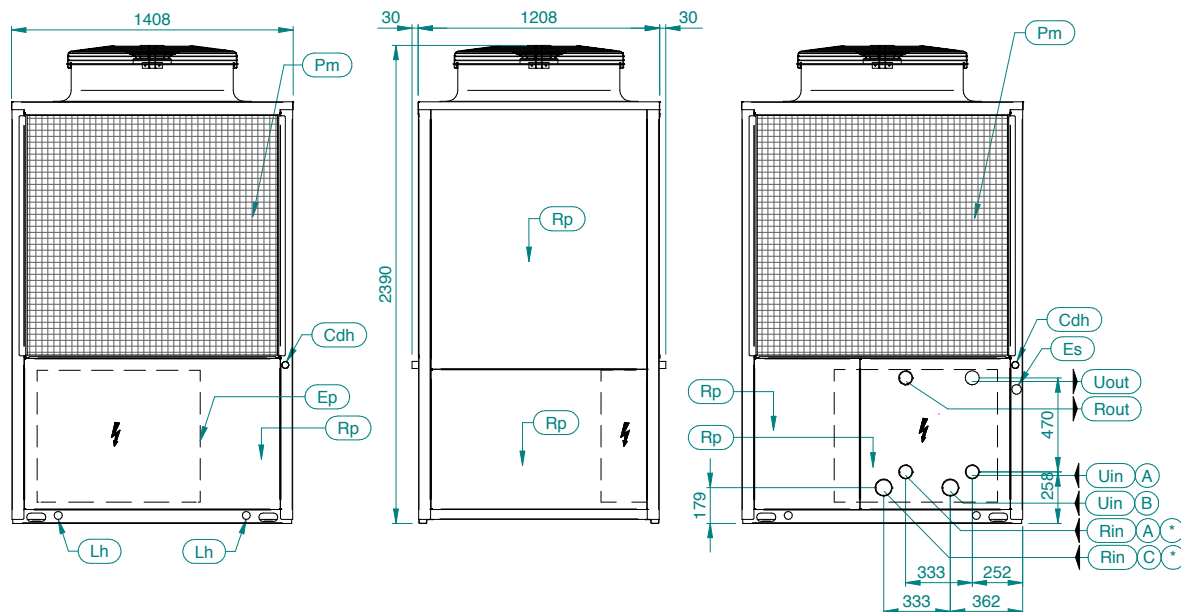

SPAZI DI INSTALLAZIONE \ CLEARANCES

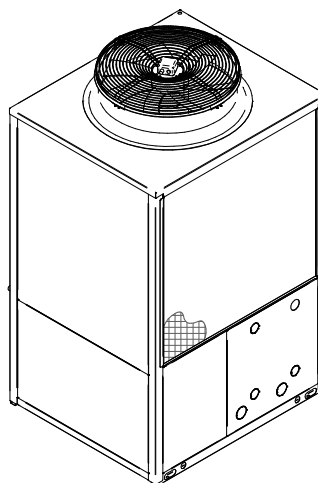

⊙ SOLO PER VERIONE DWS  
ONLY DWS VERSION

Ep	QUADRO ELETTRICO ELECTRICAL PANEL	Cdh	SCARICO CONDENSA CONDENSATE DRAIN	ø35
Es	INGRESSO ALIMENTAZIONE ELETTRICA ELECTRICAL SUPPLY INLET	Uin	INGRESSO ACQUA UTILIZZO USER WATER INLET	1"1/2 BSPM (A) 2" BSPM (B)
Lh	FORI DI SOLLEVAMENTO LIFTING HOLES	Uout	USCITA ACQUA UTILIZZO USER WATER OUTLET	1"1/2 BSPM
Pm	GRIGLIE DI PROTEZIONE PROTECTIVE METAL MESH	Rin	USCITA ACQUA RECUPERO RECOVERY WATER OUTLET	1"1/2 BSPM (A) 2" BSPM (C)
Rp	PANNELLO ASPORTABILE REMOVABLE PANEL	Rout	USCITA ACQUA RECUPERO RECOVERY WATER OUTLET	1"1/2 BSPM

CONNESSIONI IDRAULICHE / HYDRAULIC CONNECTION

- (A) ACQUA UTILIZZO/RECUPERO SENZA MODULO IDRAULICO  
USER/RECOVERY WATER WITHOUT HYDRAULIC MODULE
- (B) ACQUA UTILIZZO CON MODULO IDRAULICO 1P-2P  
USER WATER WITH HYDRAULIC MODULE 1P-2P
- (C) ACQUA RECUPERO CON MODULO IDRAULICO 1P  
RECOVERY WATER WITH HYDRAULIC MODULE 1P

DIMENSIONI / DIMENSIONS		
LUNGHEZZA WIDTH	PROFONDITA' DEPTH	ALTEZZA HEIGHT
1408	1208	2390

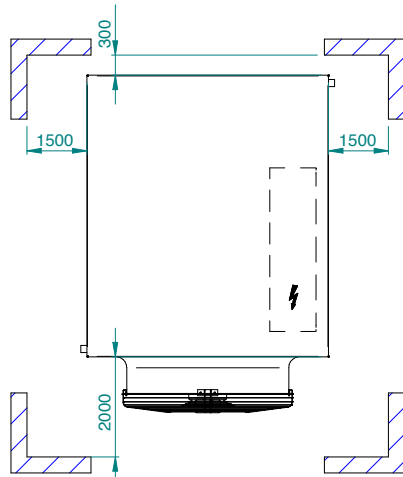
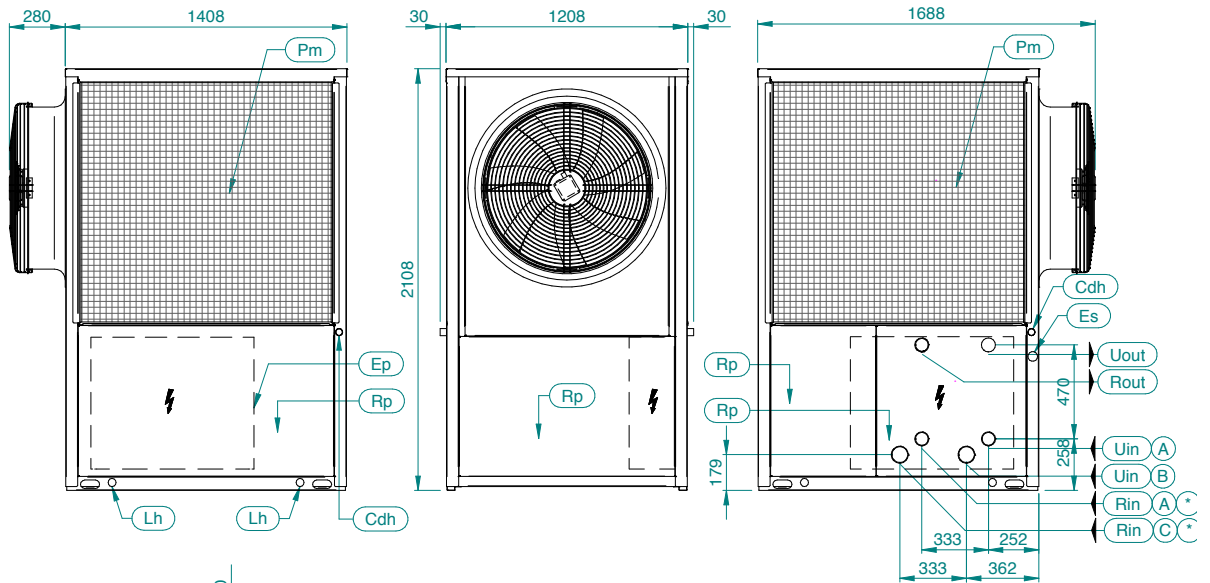

SPAZI DI INSTALLAZIONE \ CLEARANCES

\* SOLO PER VERSIONE DWS  
ONLY DWS VERSION

Ep	QUADRO ELETTRICO ELECTRICAL PANEL	Cdh	SCARICO CONDENSA CONDENSATE DRAIN	ø35
Es	INGRESSO ALIMENTAZIONE ELETTRICA ELECTRICAL SUPPLY INLET	Uin	INGRESSO ACQUA UTILIZZO USER WATER INLET	1"1/2 BSPM (A) 2" BSPM (B)
Lh	FORI DI SOLLEVAMENTO LIFTING HOLES	Uout	USCITA ACQUA UTILIZZO USER WATER OUTLET	1"1/2 BSPM
Pm	GRIGLIE DI PROTEZIONE PROTECTIVE METAL MESH	Rin	USCITA ACQUA RECUPERO RECOVERY WATER OUTLET	1"1/2 BSPM (A) 2" BSPM (C)
Rp	PANNELLO ASPORTABILE REMOVABLE PANEL	Rout	USCITA ACQUA RECUPERO RECOVERY WATER OUTLET	1"1/2 BSPM

CONNESSIONI IDRAULICHE / HYDRAULIC CONNECTION

- (A) ACQUA UTILIZZO/RECUPERO SENZA MODULO IDRAULICO  
USER/RECOVERY WATER WITHOUT HYDRAULIC MODULE
- (B) ACQUA UTILIZZO CON MODULO IDRAULICO 1P-2P  
USER WATER WITH HYDRAULIC MODULE 1P-2P
- (C) ACQUA RECUPERO CON MODULO IDRAULICO 1P  
RECOVERY WATER WITH HYDRAULIC MODULE 1P

DIMENSIONI / DIMENSIONS		
LUNGHEZZA WIDTH	PROFONDITA' DEPTH	ALTEZZA HEIGHT
1688	1208	2108



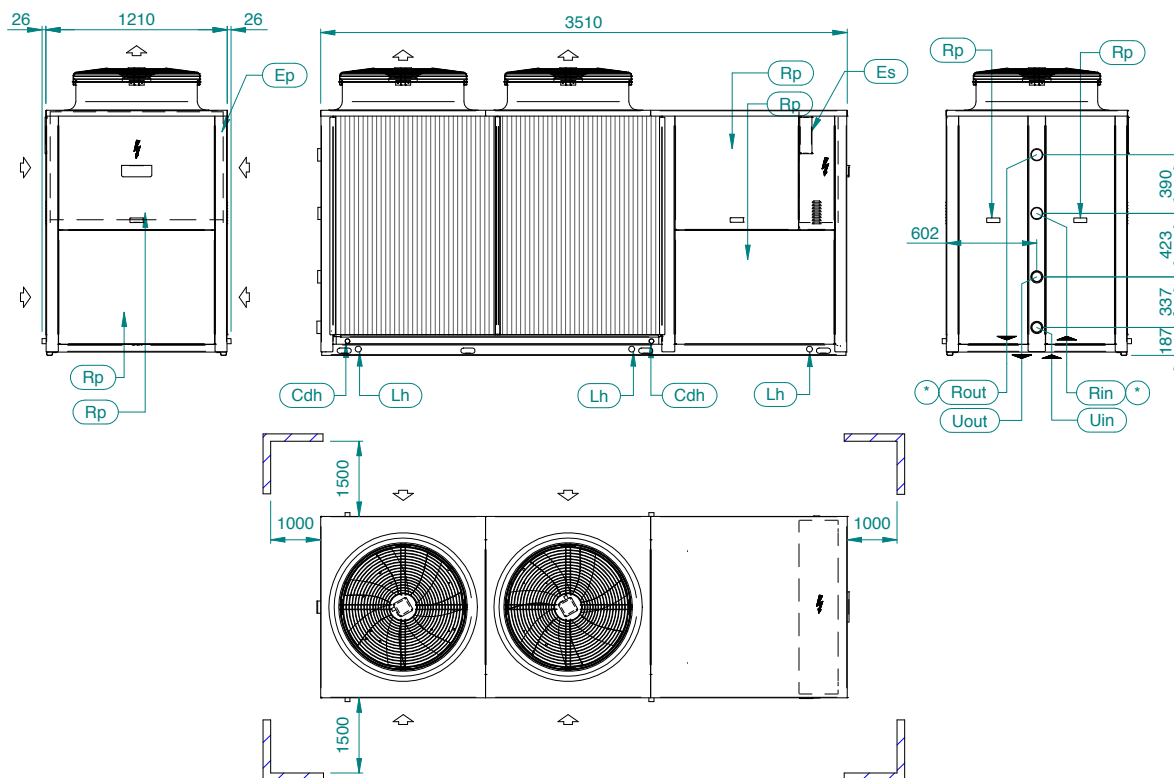

SPAZI D' INSTALLAZIONE \ CLEARANCES

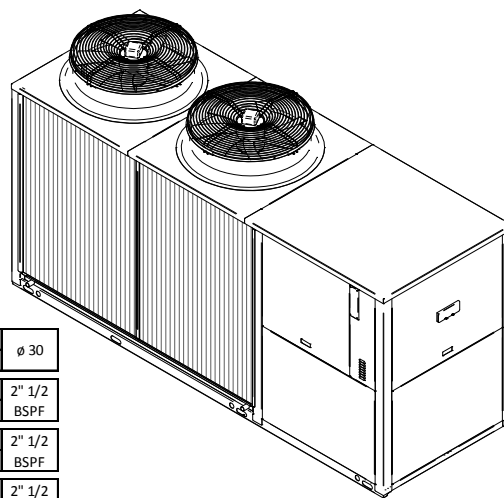

SOLO PER VERSIONE DWS  
ONLY DWS VERSION

DIMENSIONI - DIMENSIONS		
LUNGHEZZA WIDTH	PROFONDITA' DEPTH	ALTEZZA HEIGHT
3510	1262	1912

Ep	QUADRO ELETTRICO ELECTRICAL PANEL	Cdh	SCARICO CONDENSA CONDENSATE DRAIN	ø 30
Es	INGRESSO ALIMENTAZIONE ELETTRICA ELECTRICAL SUPPLY INLET	Uin	INGRESSO ACQUA UTILIZZO USER WATER INLET	2" 1/2 BSPF
Lh	FORI SOLLEVAMENTO LIFTING HOLES	Uout	USCITA ACQUA UTILIZZO USER WATER OUTLET	2" 1/2 BSPF
Rp	PANNELLO ASPORTABILE REMOVABLE PANEL	Rin	INGRESSO ACQUA RECUPERO RECOVERY WATER INLET	2" 1/2 BSPF
↔	FLUSSO ARIA AIR FLOW	Rout	USCITA ACQUA RECUPERO RECOVERY WATER OUTLET	2" 1/2 BSPF

# Black HT 145 - 180

Technical book  
BLACK HT

# 7

DIMENSIONAL  
DRAWING

34

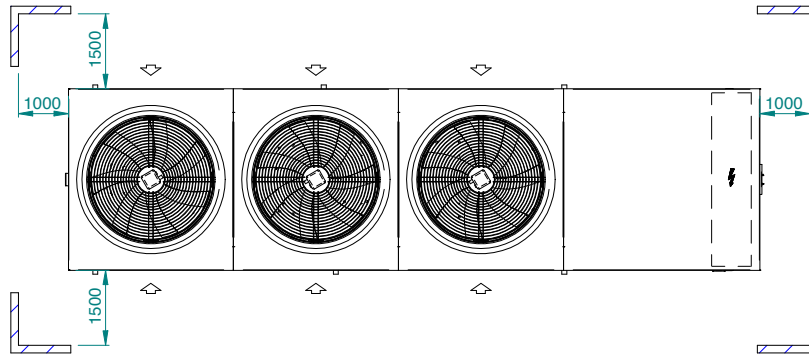
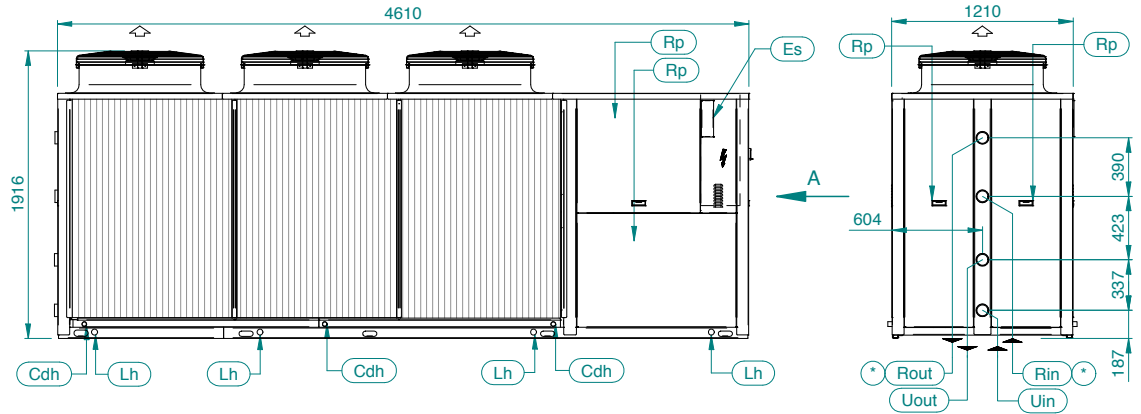

SPAZI D' INSTALLAZIONE \ CLEARANCES

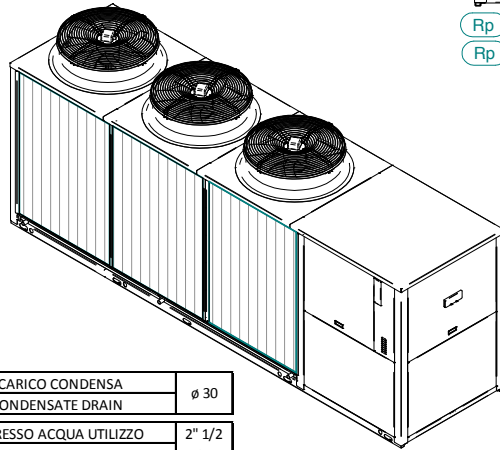
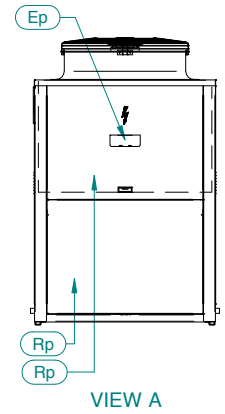

Ep	QUADRO ELETTRICO	Cdh	SCARICO CONDENSA	Uin	INGRESSO ACQUA UTILIZZO
	ELECTRICAL PANEL		CONDENSATE DRAIN		USER WATER INLET
Es	INGRESSO ALIMENTAZIONE ELETTRICA	Uout	USCITA ACQUA UTILIZZO	Rp	PANNELLO ASPORTABILE
	ELECTRICAL SUPPLY INLET		USER WATER OUTLET		REMOVABLE PANEL
Lh	FORI SOLLEVAMENTO	⇐	FLUSSO ARIA		
	LIFTING HOLES		AIR FLOW		
Rp					

DIMENSIONI - DIMENSIONS		
LUNGHEZZA	PROFONDITA'	ALTEZZA
WIDTH	DEPTH	HEIGHT
4610	1210	1916

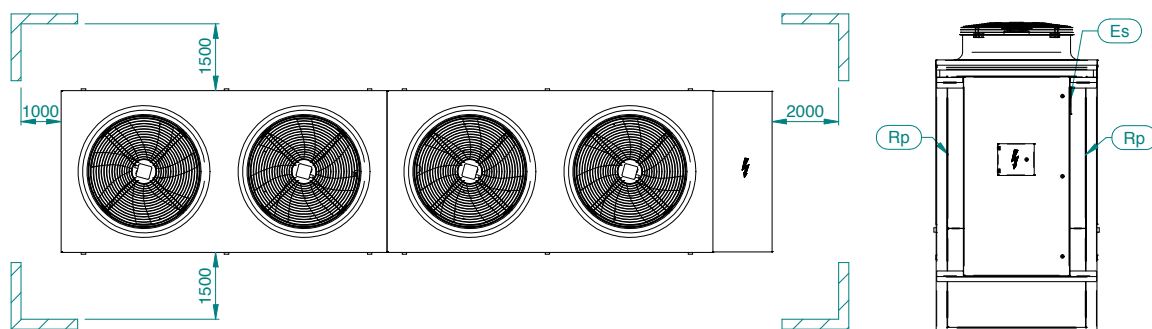
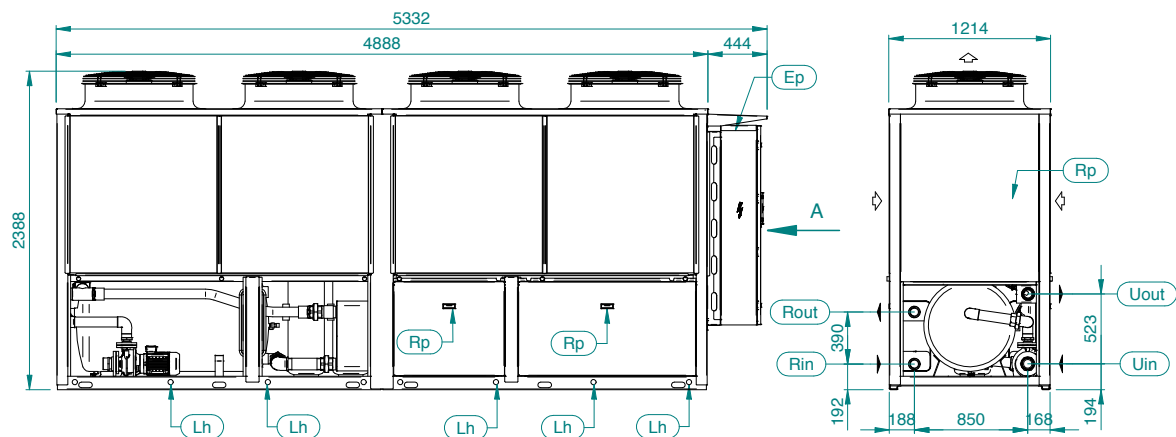

SPAZI D'INSTALLAZIONE \ CLEARANCES

VIEW A

CONNESSIONI IDRAULICHE \ HYDRAULIC CONNECTION				
	Uin	Uout	Rin	Rout
235	3" BSPF	3" BSPF	3" BSPM	3" BSPM

DIMENSIONI / DIMENSIONS		
LUNGHEZZA WIDTH	PROFONDITA' DEPTH	ALTEZZA HEIGHT
5329	1211	2388

Ep	QUADRO ELETTRICO ELECTRICAL PANEL	Uin	INGRESSO ACQUA UTENZA USER WATER INLET
Es	ALIMENTAZIONE ELETTRICA ELECTRICAL SUPPLY	Uout	USCITA ACQUA UTENZA USER WATER OUTLET
Lh	FORI DI SOLLEVAMENTO LIFTING HOLES	Rin	INGRESSO ACQUA RECUPERO RECOVERY WATER INLET
Rp	PANNELLO REMOVIBILE REMOVABLE PANEL	Rout	USCITA ACQUA RECUPERO RECOVERY WATER OUTLET
↔	FLUSSO ARIA AIR FLOW		

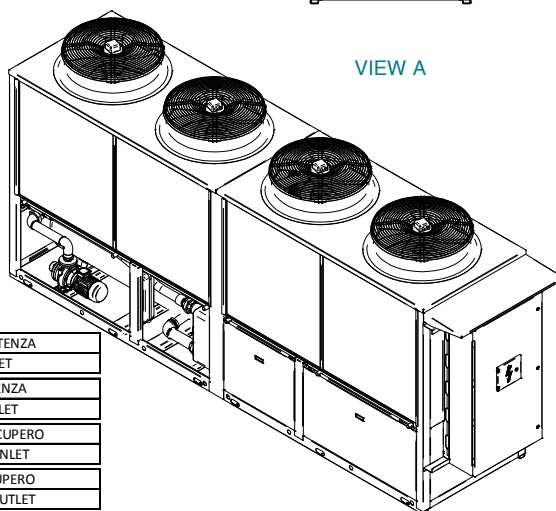



**ENERBLUE S.r.l.**

**Sede legale**

Via dell'Industria, 24  
35028 PIOVE di SACCO - (Padova) Italy

**Sede operativa**

Via G. Puccini, 9  
30010 CANTARANA di CONA - (Venezia) Italy

Tel. +39.0426.302051  
Fax +39.0426.840000

[info@enerblue.it](mailto:info@enerblue.it)

[www.enerblue.it](http://www.enerblue.it)