



## AQUACIAT<sup>POWER</sup> LD

Water chillers



### Energy excellence

*Compact and silent*

*Scroll compressors*

*Shell and tube or brazed plate heat exchangers*

*All-aluminium micro-channel condenser*

*Self-adjusting electronic control*

Cooling capacity: 168 to 520 kW



Cooling only



Hydraulic module



Heat recovery



## USE

The new generation of **AQUACIAT<sup>POWER</sup>** high efficiency air-to-water water chillers offers an optimal solution for all cooling applications used for the Office, Healthcare, Industry, Administration, Retail and Collective housing sectors.

These units are designed for outdoor installation and require no special protection against adverse weather conditions.

The **AQUACIAT<sup>POWER</sup>** is optimised to use ozone-friendly HFC R410A refrigerant.

This range guarantees compliance with the most demanding requirements for increased seasonal energy efficiency (SEER and SEPR) and CO<sub>2</sub> reduction to comply with the various applicable European directives and regulations.

## RANGE

### AQUACIAT<sup>POWER</sup> LD ST series

Standard cooling only version.

The product is optimised to meet the most demanding technical and economic requirements.

### AQUACIAT<sup>POWER</sup> LD HE series



Cooling only high seasonal energy efficiency version.

The product is optimised for part load applications for which an optimum SEER and SEPR value is required. In this case, the machine is equipped as standard with AC fans + external speed regulator allowing for optimisation of the part load efficiency throughout the year.

### DESCRIPTION

AQUACIAT<sup>POWER</sup> units are packaged machines supplied as standard with the following components:

- Hermetic SCROLL compressors
- Chilled-water evaporator, either:
  - brazed plate
- Air-cooled exchanger, all-aluminium micro-channel coil with axial fan motor assembly
- Electrical power and remote control cabinet:
  - 400V-3ph-50Hz (+/-10%) general power supply + Earth
  - transformer fitted as standard on the machine for supplying the remote control circuit with 24V
- Connect Touch electronic control module.
- Casing for outdoor installation.

The entire AQUACIAT<sup>POWER</sup> range complies with the following EC directives and standards:

- Machinery directive 2006/42/EC
- Electromagnetic compatibility directive 2014/30/EC
- EMC immunity and emissions EN 61800-3 "C3"
- Low voltage directive 2014/35/EU
- RoHS 2011/65/EU
- Pressure equipment directive (PED) 2014/68/EU
- Machinery directive EN 60-204 - 1
- Refrigeration systems and heat pumps EN 378-2
- Commission Regulation (EU) No. 2016/2281 implementing directive 2009/125/EC setting the ecodesign requirements.

### DESCRIPTION

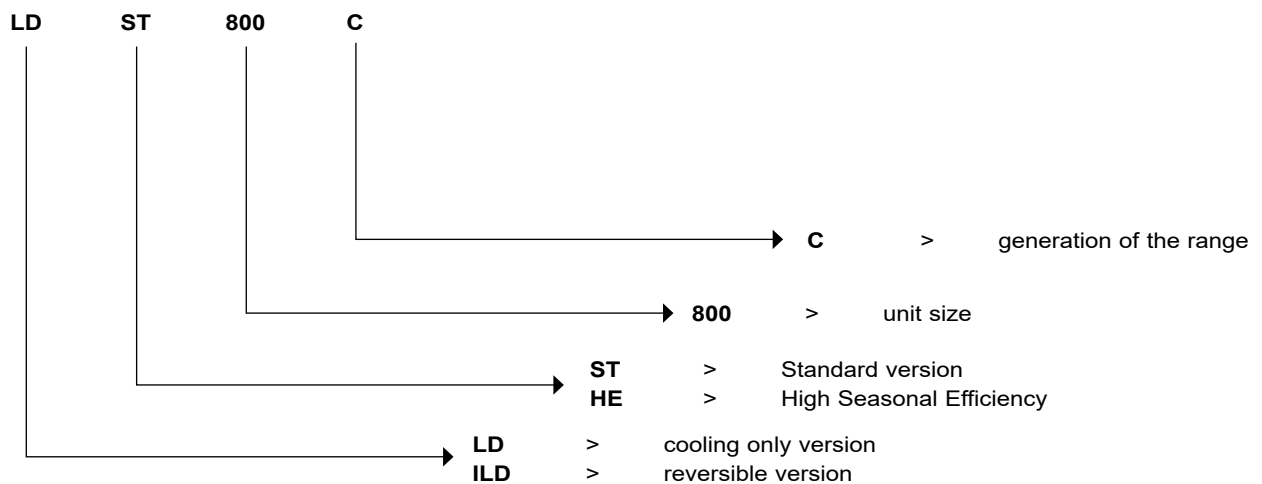

### CONFIGURATION

ST	Standard	HE	High Seasonal Efficiency
ST LN option	Standard Low Noise	HE LN option	High Seasonal Efficiency Low Noise
ST XLN option	Standard Xtra Low Noise	HE XLN option	High Seasonal Efficiency Xtra Low Noise

### DESCRIPTION OF THE MAIN COMPONENTS

#### ■ Compressors

- Hermetic SCROLL type
- Electronic motor overheating protection
- Crankcase heater
- Mounted on anti-vibration mounts

#### ■ Evaporator

- Exchanger type:
  - asymmetrical brazed plate
- Plate patterns optimised for high efficiency
- 19 mm armaflex thermal insulation

#### ■ Condenser

- Air-cooled exchanger, all-aluminium micro-channel coil
- Axial fans with composite blades offering an optimised profile, fixed speed (ST version) or variable speed (HE version)
- Motors – IP 54, class F

#### ■ Refrigerant accessories

- Dehumidifier filters with rechargeable cartridges
- Hygroscopic sight glasses
- Electronic expansion valves
- Service valves on the liquid line

#### ■ Regulation and safety instruments

- Low and high pressure sensors
- Safety valves on the refrigerant circuit
- Water temperature control sensors
- Evaporator antifreeze protection sensor
- Factory-fitted evaporator water flow controller

#### ■ Electrical cabinet

- Electrical cabinet with IP 44 protection rating
- A connection point without neutral
- Front-mounted main safety switch with handle
- Control circuit transformer
- 24V control circuit
- Fan and compressor motor circuit breaker
- Fan and compressor motor contactors
- Connect Touch microprocessor-controlled electronic control module
- Wire numbering
- Marking of the main electrical components



#### ■ Connect Touch control module

- User interface with 4.3 inch touch screen
- Intuitive, user-friendly navigation using icons
- Clear text display of information available in 8 languages (F-GB-D-NL-E-I-P - Chinese + free)



The electronic control module performs the following main functions:

- Regulation of the chilled water temperature (at the return or at the outlet)
- Regulation of the water temperature based on the outdoor temperature (water law)
- Regulation for low temperature energy storage
- Second setpoint management
- Complete management of compressors with start-up sequence, timer and runtime balancing
- Self-regulating and proactive functions with adjustment of the control based on parameter drift
- In-series staged power control system on the compressors according to the thermal requirements
- Management of compressor short-cycle protection
- Frost protection (exchanger heater option)
- Phase reversal protection
- Management of occupied/unoccupied modes (according to the time schedule)
- Compressor and pump runtime balancing
- Management of the machine operation limit according to the outdoor temperature
- Sound level reduction device (night mode according to the user programme) with limitation of compressor capacity and fan speed
- Diagnosis of fault and operating statuses
- Management of a fault memory allowing a log of the last 50 incidents to be accessed, with operating readings taken when the fault occurs
- Blackbox memory
- Master/slave management of the two machines in parallel with runtime balancing and automatic changeover if a fault occurs on one machine
- Weekly and hourly time schedule for the machine, including 16 periods of absence
- Pump standby based on demand (energy saving)
- Calculation of the water flow rate and operating pressure (hydraulic module version)
- Electronic adjustment of the water pump speed and water flow rate (variable speed pump option)
- Display of all machine parameters (3 access levels, User/Maintenance/Factory, password-protected): temperature, setpoints, pressures, water flow rate (hydraulic version), runtime.
- Display of trend curves for the main values
- Storage of maintenance manual, wiring diagram and spare parts list.
- Innovative smart energy monitoring, providing users with smart data such as real-time electric energy consumption and heating and cooling capacity, and instantaneous and average energy efficiency rates.

### ■ Connect Touch remote management

Connect Touch is equipped as standard with an RS485 port and an ETHERNET (IP) connection, offering a range of options for remote management, monitoring and diagnostics.

Using the integrated Webserver, a simple internet connection uses the unit's IP address to access the Connect Touch interface on the PC, facilitating everyday management tasks and maintenance operations.

A range of communication protocols are available: MODBUS/JBUS RTU (RS485) or TC/IP as standard, LONWORKS – BACNET IP as an option, enabling most CMS/BMS to be integrated

Several contacts are available as standard, enabling the machine to be controlled remotely by wired link:

- Automatic operation control: when this contact is open, the machine stops
- Setpoint 1/setpoint 2 selector: when this contact is closed, a second cooling setpoint is activated (energy storage or unoccupied mode, for example)
- Power limitation: closing the contact concerned allows the power or refrigerating consumption of the machine to be limited by stopping one or more compressors (this limit can be set with a parameter)
- Fault reporting: this contact indicates the presence of a major fault which has caused one or both refrigerant circuits to stop
- Operational status reporting: indicates that the unit is in production mode
- Activation control for partial energy recovery using the desuperheater
- Switch control for the customer pump, external to the machine (on/off).
- Pump control: 0/10V signal to control external variable speed pump

Contacts available as an option:

- Setpoint adjustable via 4-20 mA signal: this input is used to adjust the setpoint in COOLING mode
- Power limitation adjustable by 4-20 mA signal
- Second power limitation level
- Power indication: analogue output (0-10 V) providing an indication of the unit's load rate
- User fault reporting: enables integration of a fault in the water loop
- General fault reporting: this contact indicates that the unit has stopped completely
- Alert reporting: this contact indicates the presence of a minor fault which did not cause the circuit in question to stop
- End of storage signal: enables return to the second setpoint at the end of the storage cycle
- Schedule override: closing this contact cancels the time schedule
- Desuperheater activation control
- Desuperheater pump On/Off control

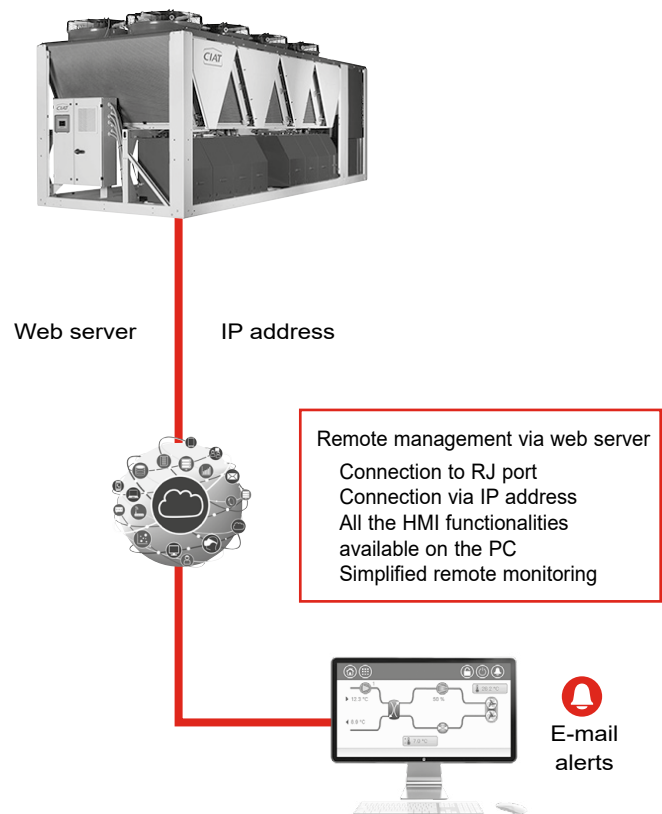

### ■ CIATM2M, the CIAT supervision solution

CIATM2M is a remote supervision solution dedicated to monitoring and controlling several CIAT machines in real time.

#### Advantages

- Access to the operating trend curves for analysis
- Improved energy performance
- Improved availability rate for the machines

#### Functions

CIATM2M will send data in real time to the supervision website, [www.ciatm2m.com](http://www.ciatm2m.com).

The machine operating data can be accessed from any PC, smartphone or tablet.

Any event can be configured to trigger a mail alert.

Parameters monitored:

- Overview
- Control panel for the controllers
- Events
- Temperature curves

Monthly and annual reports are available to analyse:

- The performance and operation of the machine  
Example: operating curves and time, number of compressor start-ups, events, preventive maintenance actions to be performed, etc.

Incidents such as a drift in the measurements on a temperature sensor, incorrectly set control parameters, or even incorrect settings between one compressor stage and the other, are immediately detected, and the corrective actions put in place.

#### Equipment

This kit can be used on both machines which are already in use (existing inventory), and on new machines which do not have sufficient space in their electrical cabinets.

- 1 transportable cabinet
- 1 wall-mounted antenna

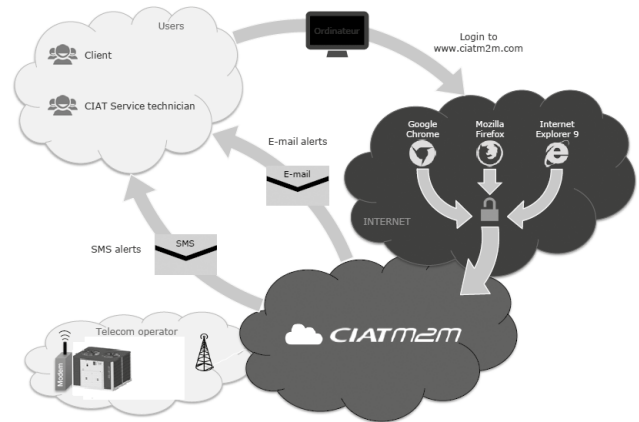

#### CIATM2M kit contents

- 1 GPRS / 3G modem
- 1 SIM card
- 1 24 VDC power supply
- 1 power protection device
- 1 GSM antenna
- Rail mounting
- Enclosed casing to protect the equipment during transport
- Packing box for cable routing (bus, power supply, Ethernet)

#### Compatibility

Up to three machines per CIATM2M kit

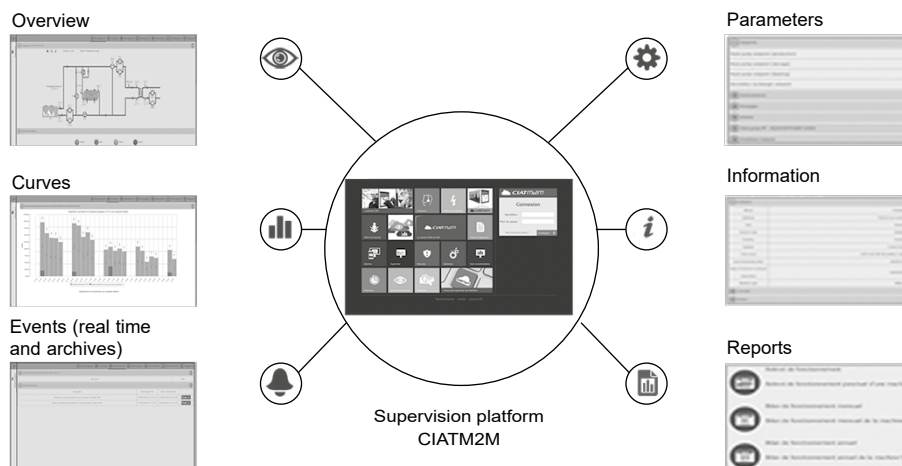

## AVAILABLE OPTIONS

Options	Description	Advantages	LD ST / HE 602-2000
Medium temperature brine solution	Low temperature chilled water production down to 0 °C with ethylene glycol and propylene glycol.	Covers specific applications such as ice storage and industrial processes	●
Low temperature brine solution	Low temperature chilled water production down to -15 °C with ethylene glycol and -12 °C with propylene glycol.	Covers specific applications such as ice storage and industrial processes	602 to 1500
XtraFan	Unit equipped with specific variable-speed fans : XtraFans (See specific chapter for maximum available static pressure according to size), each fan equipped with a connection flange & sleeves allowing the connection to the ducting system.	Ducted fan discharge, optimised temperature control, based on the operating conditions and system characteristics	All HE version
Low Noise	Aesthetic and sound absorbing compressor enclosure	Noise level reduction	●
Xtra Low Noise	Aesthetic and sound absorbing compressor enclosure associated with low-speed fans	Noise emission reduction at reduced fan speed	●
IP54 control box	Increased leak tightness of the unit	Protects the inside of the electric box from dust, water and sand. In general this option is recommended for installations in polluted environments	●
Protection grilles	Metal grilles on the 4 unit sides.	Improves protection against intrusion to the unit interior, coil and piping protection against impacts.	●
Soft Starter	Electronic starter on each compressor	Reduced start-up current	●
Variable speed fans for winter operation cooling mode down to -20 °C	AC fan control using a variable speed control. One inverter on each refrigerant circuit	Stable unit operation when the air temperature is between 0 °C and -20 °C.	ALL ST version
Water exchanger frost protection	Electric heater on the water exchanger and the water piping	Water exchanger module frost protection between 0 °C and -20 °C outside air temperature	●
Exchanger and hydraulic module frost protection	Electric heater on the water exchanger hydraulic module and optional expansion tank	Water type heat exchanger and hydraulic module frost protection down to an outdoor air temperature of -20 °C	ALL units with pump option
Exchanger and hydraulic module frost protection	Electric heater on the water exchanger hydraulic module and optional expansion tank & water buffer tank	Water type heat exchanger and hydraulic module frost protection down to an outdoor air temperature of -20 °C	ALL with water buffer tank
Partial heat recovery	Unit equipped with one desuperheater on each refrigerant circuit	Production of free high-temperature hot-water simultaneously with chilled water production (or hot water for heat pump)	●
Master/slave operation	Unit equipped with supplementary water outlet temperature sensor kit (to be field installed) allowing master/slave operation of two units connected in parallel	Optimised operation of two units connected in parallel operation with runtime balancing	●
Shell and tube evaporator aluminium insulation	Evaporator covered with an aluminium jacket for thermal insulation protection	Improved resistance to aggressive climate conditions	602 to 1000
Compressor suction and discharge valves	Shut-off valves on the compressor suction and discharge piping	Simplified maintenance. Possibility to store the refrigerant charge in the cooler or condenser side during servicing	●
Compressor discharge valves	Shut-off valves on the compressor discharge piping	Simplified maintenance. Possibility to store the refrigerant charge in the condenser side during servicing	●
HP single-pump hydraulic module	Single high-pressure water pump, water filter, electronic water flow control, pressure transducers. For more details, refer to the dedicated chapter (expansion tank not included). Option with built-in safety hydraulic components available.)	Easy and fast installation (plug & play)	602 to 1500
HP dual-pump hydraulic module	Dual high-pressure water pump, water filter, electronic water flow control, pressure transducers. For more details, refer to the dedicated chapter (expansion vessel not included; option with built-in safety hydraulic components available)	Easy and fast installation (plug & play)	602 to 1500

● ALL MODELS

Refer to the selection tool to find out which options are not compatible.

## AVAILABLE OPTIONS

Options	Description	Advantages	LD ST / HE 602-2000
LP single-pump hydraulic module	Single low-pressure water pump, water filter, electronic water flow control, pressure transducers. For more details, refer to the dedicated chapter (expansion tank not included; option with built-in hydraulic safety components available)	Easy and fast installation (plug & play)	602 to 1500
LP dual-pump hydraulic module	Dual low-pressure water pump, water filter, electronic water flow control, pressure transducers. For more details, refer to the dedicated chapter (expansion tank not included; option with built-in hydraulic safety components available)	Easy and fast installation (plug & play)	602 to 1500
HP evap. variable-speed single-pump	Single high-pressure water pump with variable speed drive (VSD), water filter, electronic water flow control, pressure transducers. Multiple water flow control options. For more details, refer to the dedicated chapter (expansion tank not included; option with built-in hydraulic safety components available)	Quick and easy installation (plug & play), significant pumping energy cost savings (more than two-thirds), tighter water flow control, improved system reliability	●
HP variable-speed dual pump.	Dual high-pressure water pump with variable speed drive (VSD), pressure transducers. Multiple water flow control options. For more details, refer to the dedicated chapter (expansion tank not included; option with built-in hydraulic safety components available)	Quick and easy installation (plug & play), significant pumping energy cost savings (more than two-thirds), tighter water flow control, improved system reliability	●
Lon gateway	Bi-directional communication board complying with Lon Talk protocol	Connects the unit by communication bus to a building management system	●
BACnet/IP	Bi-directional high-speed communication using BACnet protocol over Ethernet network (IP)	Easy and high-speed connection by ethernet line to a building management system. Allows access to multiple unit parameters	●
Energy Management Module	Control board with additional inputs/outputs. See Contacts available in option on control description.	Extended remote control capabilities (setpoint reset by 0-20 mA input, ice storage end, demand limits, boiler on/off command...)	●
Contact for refrigerant leak detection	0-10 V signal to report any refrigerant leakage directly on the unit (the leak detector must be supplied by the customer)	Immediate customer notification of refrigerant losses to the atmosphere, allowing timely corrective actions	●
Dual relief valves on 3-way valve	Three-way valve upstream of relief valves on the shell and tube evaporator	Valve replacement and inspection facilitated without refrigerant loss. Conforms to European standard EN378/BGVD4	602 to 1000
Compliance with Russian regulations	EAC certification	Compliance with Russian regulations	●
Power factor correction	Capacitors for automatic regulation of power factor (cos phi) value to 0,95.	Reduction of the apparent electrical power, compliance with minimum power factor limit set by utilities	●
MCHE anti-corrosion protection Protect2	Coating by conversion process which modifies the surface of the aluminium producing a coating that is integral to the coil. Complete immersion in a bath to ensure 100% coverage. No heat transfer variation, tested 4000 hours salt spray per ASTM B117	Protect2 Improved corrosion resistance of the MCHE coils by 2, recommended for use in moderately corrosive environments	●
MCHE anti-corrosion protection Protect4	Flexible, durable polyepoxide coating applied using an electro coating process to give micro-channel coils an anti-UV top layer. Minimal variation in the thermal transfer, tested to withstand more than 6000 hours of constant neutral salt spray as per ASTM B117, improved impact resistance as per ASTM D2794	Protect4 Improved corrosion resistance of the MCHE coils by 4, recommended for use in corrosive environments	●
Shell and tubes heat exchanger	Brazed plate heat exchanger replaced by shell & tube heat exchanger	Extended water flow range, reinforced fouling resistance	602 to 1000
230V electrical plug	230V AC power supply source provided with plug socket and transformer (180 VA, 0.8 Amps)	Permits connection of a laptop or an electrical device during unit commissioning or servicing	●
Expansion vessel	6 bar expansion tank integrated in the hydraulic module (requires hydraulic module option)	Easy and fast installation (plug & play), & protection of closed water systems from excessive pressure	ALL units with pump option
Screwed water connection sleeve kit for DSH	DSH connections with screw connection sleeves	Easy installation. Used to connect the unit to a screw connector	●

- ALL MODELS

Refer to the selection tool to find out which options are not compatible.

## AVAILABLE OPTIONS

Options	Description	Advantages	LD ST / HE 602-2000
M2M supervision (accessory)	Monitoring solution which allows customers to track and monitor their equipment remotely in real time	Real-time expert technical support to improve equipment availability and reports at customer hand to monitor and optimize operating equipment.	●
Water buffer tank module	Integrate water buffer tank	Avoid short cycle on compressors and ensure a stable water in the loop	ALL units with pump option
Anti-vibration mounts (kit)	Elastomer antivibratils mounts to be place under the unit (Material classified B2 fire class according to DIN 4102).	Isolate the unit from the building, avoid transmission of vibration and associate noise to the building. Must be associated with a flexible connection on water side	●
Exchangers flexibles connection (kit)	Flexibles connections on the exchanger water side	Easy installation. Limit transmission of vibrations on the water network	●
Exchangers water filter (kit)	Water filter	Eliminate dust in the water network	ALL units without pump option
Set point adjustment by 4-20mA signal	Connections to allow a 4-20mA signal input	Easy energy management, allow to adjust set point by a 4-20mA external signal	●
Free Cooling dry cooler management	Control & connections to a Free Cooling Drycooler Opera or Vextra fitted with option FC control box	Easy system management, Extended control capabilities to a drycooler used in Free Cooling mode	●
Evap. single pump power/ control circuit	Unit equipped with an electrical power and control circuit for one pump evaporator side	Quick and easy installation: the control of fixed speed pumps is embedded in the unit control	●
Evap. dual pumps power/ control circuit	Unit equipped with an electrical power and control circuit for two pumps evaporator side	Quick and easy installation: the control of fixed speed pumps is embedded in the unit control	●
Plastic sheeting	Plastic sheeting covering the unit, with strapping securing it on the wooden pallet.	Protects the machine from dust and dirt from outside while the unit is being transported and stored.	●

- ALL MODELS

Refer to the selection tool to find out which options are not compatible.



## SEASONAL PERFORMANCE

---

Most central air conditioning systems installed in the tertiary sector in Europe use water chillers to provide refrigeration. Analyses of installed systems show that the heat load varies from season to season and that a water chiller operates at reduced capacity for the majority of the time.

The efficiency under partial load is therefore essential when choosing a water chiller. It is with this in mind that the new AQUACIAT<sup>POWER</sup> range was designed. In particular, the entire range uses R410A refrigerant which, thanks to its thermodynamic performance, makes it possible to obtain much higher levels of seasonal performance.

As its compressors are connected in parallel on a single refrigerant circuit, the AQUACIAT<sup>POWER</sup> easily and efficiently adjusts the cooling capacity to the system's needs. The self-adjusting Connect Touch/Connect 3 control anticipates variations in load and starts only the number of compressors needed. This ensures optimum operation of the compressors and guarantees energy efficiency for the majority of the system's life.

The high seasonal energy efficiency AQUACIAT<sup>POWER</sup> HE series has EC-type variable-speed fan motor assemblies as standard, enabling the machine's part-load performance to be improved, along with its seasonal performance (SEER and SEPR).

The **Seasonal Energy Efficiency Ratio (SEER)** measures the seasonal energy efficiency of liquid chillers **for comfort applications** by calculating the ratio between the annual cooling demand of the building and the chiller's annual energy demand. It takes into account the energy efficiency for each outdoor temperature weighted by the number of hours observed for each of these temperatures, using actual climate data. The **SEER** is a new way of measuring the energy efficiency of liquid chillers for **comfort applications** over an entire year. The new indicator provides a more realistic overview of the cooling system's energy efficiency and its actual impact on the environment (Ecodesign regulation 2016/2281).

The **(Seasonal Energy Performance Ratio) (SEPR)** measures the seasonal energy efficiency of liquid chillers for **process applications** by calculating the ratio between the annual process cooling demand and the chiller's annual energy demand. It takes into account the energy efficiency at each outdoor temperature for the average European climate weighted by the number of hours observed for each of these temperatures.

The **SEPR** is a new way of measuring the energy efficiency of liquid chillers for **process applications** over an entire year. The new indicator provides a more realistic overview of the cooling system's energy efficiency and its actual impact on the environment (Ecodesign regulation 2015/1095 and 2016/2281).

### HYDRAULIC MODULE

#### ■ The "ALL-IN-ONE" solution

#### The PLUG & COOL solution offered by AQUACIAT<sup>POWER</sup>

Available on sizes 602 to 2000, the hydraulic module contains all the water circuit components needed for the system to operate correctly:

- Buffer tank with 19 mm insulation, 550-litre capacity (option).
- Expansion vessel (option):
  - 50 litres for models 602 to 1000.
  - 80 litres for models 1100 to 2000.
- Wide choice of pumps:
  - Single or dual pumps with runtime balancing and backup.
  - High or low pressure pumps.
  - Fixed-speed or variable-speed pumps.
- Water temperature and pressure sensors.
- Water filter.
- Relief valve.
- Drain circuit.
- Air bleed valve.
- Antifreeze protection (optional).

The components in the hydraulic system are carefully selected and factory assembled and tested to make the installation of the units simple and economical.

This ensures conditioning times, implementation times and space requirements are kept to a minimum.

#### ■ Hydraulic module

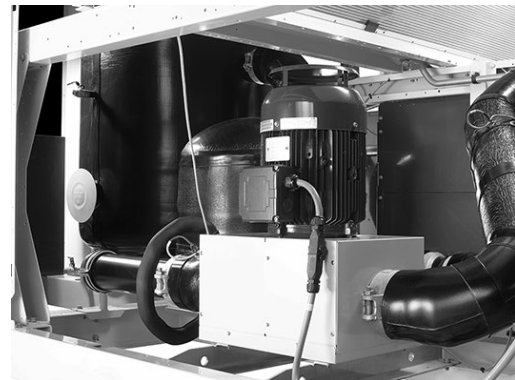

#### ■ AQUACIAT<sup>POWER</sup> hydraulic module diagram

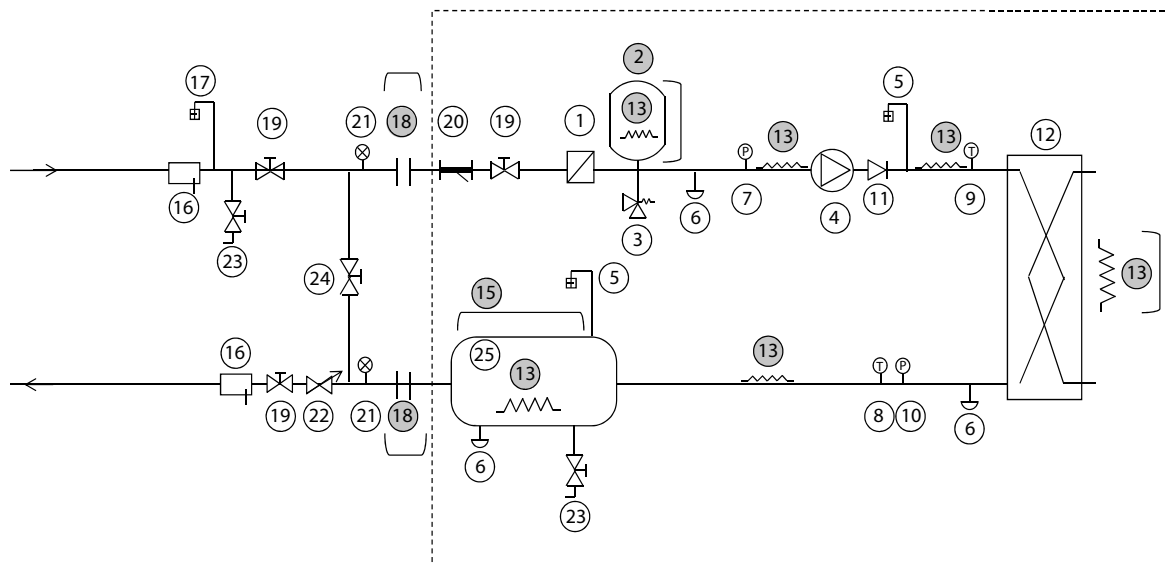

#### Components of the unit and hydraulic module

- 1 Screen filter (particle size of 1.2 mm)
  - 2 Expansion vessel
  - 3 Relief valve
  - 4 Circulating pump (single or dual)
  - 5 Air vent
  - 6 Water drain tap
  - 7 Pressure sensor  
Note: Provides information on the pump inlet pressure
  - 8 Temperature sensor  
Note: Provides information on the water type heat exchanger outlet temperature
  - 9 Temperature sensor  
Note: Provides information on the water type heat exchanger inlet temperature
  - 10 Pressure sensor  
Note: Provides information on the water type heat exchanger outlet pressure
  - 11 Internal check valve (for dual pump only)
  - 12 Plate heat exchanger
  - 13 Heater or heat trace cable for frost protection
  - 14 Water type heat exchanger flow rate sensor
  - 15 Water buffer tank module
- Option

#### System components

- 16 Pocket
  - 17 Air vent
  - 18 Flexible connection
  - 19 Shut-off valve
  - 20 800 µm screen filter (Option - mandatory in the case of a unit without hydraulic module/included on hydraulic version)
  - 21 Pressure gauge
  - 22 Water flow control valve  
Note: not required if hydraulic module with variable speed pump
  - 23 Charging valve
  - 24 Bypass valve for frost protection (if shut-off valves (item 19) are closed during winter)
  - 25 Buffer tank (if required)
- Hydraulic module (unit with hydraulic module option)

#### Notes:

- The system must be protected against frost.
- The unit's hydraulic module and the water type heat exchanger may be protected against freezing (factory-fitted option) using electric heaters and heat trace cables (13)
- The pressure sensors are fitted on connections without Schraeder. Depressurise and drain the system before any work.
- For units installed in parallel, additional devices may be required. See the section "Operation of 2 master/slave units" in the IOM.

### VARIABLE FLOW PUMP

#### ■ Description

Models 602 to 2000 may be equipped with one or two variable speed pumps which save you energy by adjusting the electrical consumption of one pump to the actual requirements of a hydraulic system, in particular for oversized installations.

#### ■ Simple to use

The "variable-speed pump" is available for LD ST/HE units, sizes 602 to 2000, and is fully integrated on the machine, with full protection, and, as it is installed outdoors, there is no need for any work in the machine room.

The assembly is factory-fitted and pre-set on the unit; it is therefore quick to install and reduces the cost of work, in particular because there is no water flow control valve on the unit's outlet.

The ability to adjust the water flow to your requirements means that the pump pressure can be adapted precisely to the actual pressure drop on the system when it is started up on-site.

#### ■ Operating principle

##### - Operation at full load

A regulator, with a direct display of the flow rate and pressure on the Connect Touch screen, enables one pump (pump A in the example below) to be adapted, by lowering its pressure P1 to the requirements of system P2, to obtain the optimal water flow rate setpoint. Electricity bills relating to the pump's consumption are reduced proportionately; this means you will see a return on investment (ROI) in only a few years, compared with the same fixed-speed pump equipped with a simple flow control valve.

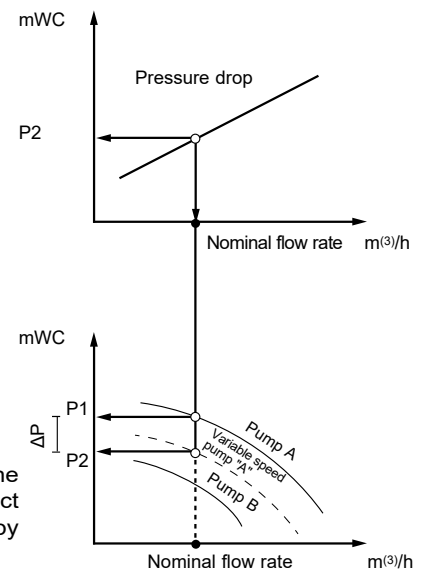

##### - Operation at part load

There are three operating modes for part load:

##### 1 - Fixed speed

The control ensures the pump continuously runs at a constant speed, based on the capacity of the compressor(s). When the compressor is powered off, the Connect Touch "standby" function manages the electrical power consumed by the pump by reducing its speed to the minimum.

**This provides energy savings of around 33%.**

##### 2 - Variable flow rate: Constant regulation of the pressure difference

The control continuously acts on the pump speed to ensure a constant pressure difference. This solution is suitable for installations with two-way valves. This control mode is used to ensure a uniform supply in each hydraulic circuit to make sure that each terminal unit operates at a satisfactory pressure

##### 3 - Variable flow rate: Constant regulation of the temperature difference

The regulation maintains a constant temperature difference whatever the load rate of the unit by reducing the flow rate to the minimum acceptable limit. This control mode is suitable for most comfort applications.

**This provides energy savings of around 66% for the pump in each of these last two operating modes**

### ENVIRONMENTAL RESPONSIBILITY

The AQUACIAT<sup>POWER</sup> contributes to sustainable development via an environmentally responsible approach, aimed at balancing ecological and economic concerns. This enables it to meet the requirements of future European thermal regulations and to protect our environment for future generations.

The highly efficient performance it offers enables energy consumption to be greatly reduced, thereby reducing the unit's carbon footprint throughout its service life.

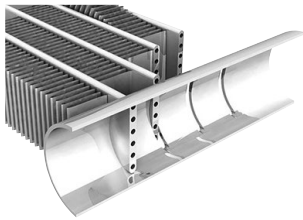

This performance is the result of the high quality components used, which have all been rigorously selected:

- The latest generation Scroll compressors
- Highly efficient R410A refrigerant, which has a low environmental impact: zero ODP (Ozone Depletion Potential), low GWP (Global Warning Potential).
- MCHE micro-channel coils
  - Energy efficiency increased by 10% compared to a conventional coil
  - 40% reduction in the refrigerant charge.
  - Reduction in the unit weight, reducing the environmental impact during transportation
  - Simplified end of life recycling thanks to the all-aluminium construction.
- Asymmetrical brazed plate heat exchangers (PBHE) (sizes 602 to 2000)
  - Reduction in the refrigerant charge compared with a tubular heat exchanger solution
  - The asymmetrical technology enables a reduction in pressure drops on the water side, and an associated drop in electricity consumption.
- Shell and tube exchangers with 3 refrigerant circuits (sizes 2100 to 2800).

AQUACIAT <sup>POWER</sup>		602	650	750	800	1000	1100	1250	1350	1500	1600	1750	2000
Refrigerant load	kg	21	24	24	25	26	35	36	41	43	50	50	54
Environmental impact	tCO <sub>2</sub> e	43	49	49	53	55	73	74	85	90	105	105	112

Only 20% of a unit's impact on the ozone layer comes from the refrigerant (direct effect), with 80% coming from the CO<sub>2</sub> released into the atmosphere when the electricity required to power the unit is produced (indirect effect). With the AQUACIAT<sup>POWER</sup>, it's a win-win situation: its low refrigerant charge minimises the risk of emissions, and its low energy consumption limits its indirect impact.

The choice of technology used in the AQUACIAT<sup>POWER</sup> range means that the TEWI, which covers the unit's environmental impact (both direct and indirect) throughout its service life, is greatly reduced.

### INTEGRATION INTO THE MOST DEMANDING ENVIRONMENTS

The AQUACIAT<sup>POWER</sup> has standard and optional equipment which enables it to be integrated into any one of a diverse

range of environments.

In the micro-channel (MCHE) coil, the rate of corrosion is less than in a conventional coil with copper tube and aluminium fins. Indeed, its all-aluminium design limits the galvanic couples in the coil, thereby providing increased corrosion resistance.

The Protect2 anti-corrosion post-treatment option doubles its resistance to corrosion. This treatment is applied by immersing the coil, ensuring complete protection as the aluminium surface undergoes a chemical change.

The Protect4 anti-corrosion post-treatment option provides a fourfold increase in resistance to corrosion. An e-coating process is used to electro-coat the coil in polymer epoxy, and then a top layer of anti-UV protection is applied.

This treatment is recommended for moderately corrosive environments.

This treatment is recommended for highly corrosive industrial and marine environments.

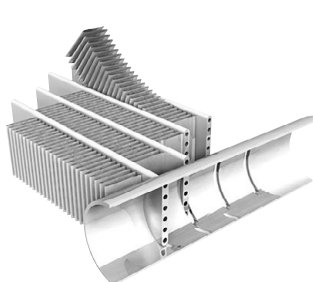

**Protect2**

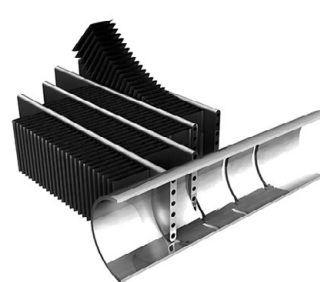

**Protect4**

In a polluted atmosphere, the AQUACIAT<sup>POWER</sup> can be equipped with an IP54 protection option that protects the electrical components from the ingress of dust, sand and water.

**TECHNICAL CHARACTERISTICS**

AQUACIAT <sup>POWER</sup> LD ST			602	650	750	800	1000	1100	1250	1350	1500
<b>Cooling</b>											
<b>Standard unit</b> Full load performances*	CA1	Nominal capacity kW	168	181	198	216	261	300	331	365	397
		EER kW/kW	3,04	3,12	2,98	2,97	2,90	2,97	2,92	2,95	2,90
	CA2	Nominal capacity kW	216	247	263	297	336	393	428	475	510
		EER kW/kW	3,6	3,89	3,59	3,7	3,37	3,53	3,4	3,47	3,37
<b>Standard unit</b> Seasonal energy efficiency**	<b>SEER<sub>12/7°C</sub> Comfort low temp.</b> kWh/kWh		<b>4,15</b>	<b>4,18</b>	<b>4,10</b>	<b>4,09</b>	<b>4,10</b>	<b>4,15</b>	<b>4,19</b>	<b>4,21</b>	<b>4,16</b>
	<b>η<sub>s</sub> cool<sub>12/7°C</sub></b> %		<b>163</b>	<b>164</b>	<b>161</b>	<b>161</b>	<b>161</b>	<b>163</b>	<b>165</b>	<b>165</b>	<b>163</b>
	SEPR <sub>12/7°C</sub> Process high temp.		kWh/kWh	4,77	4,71	4,29	4,76	4,33	4,56	4,46	4,67
<b>Unit with low temperature brine option</b> Seasonal energy efficiency**		<b>SEPR<sub>-2/-8°C</sub> Process medium temp.</b> *** kWh/kWh	<b>2,81</b>	<b>3,08</b>	<b>3,14</b>	<b>2,99</b>	<b>3,13</b>	<b>3,05</b>	<b>3,04</b>	<b>2,76</b>	<b>3,23</b>
Part Load integrated values		IPLV.SI	4,566	4,570	4,538	4,508	4,500	4,610	4,612	4,690	4,579
<b>Sound levels</b>											
<b>Standard unit</b>											
Sound power <sup>(1)</sup>		dB(A)	91	92	92	92	92	93	93	93	93
Sound pressure at 10 m <sup>(2)</sup>		dB(A)	59	60	60	60	60	60	60	61	61
<b>Unit + Low Noise option</b>											
Sound power <sup>(1)</sup>		dB(A)	89	90	90	90	90	91	91	92	92
Sound pressure at 10 m <sup>(2)</sup>		dB(A)	57	58	58	58	58	59	59	60	60
<b>Unit + Xtra Low Noise option</b>											
Sound power <sup>(1)</sup>		dB(A)	84	84	84	85	85	86	86	86	86
Sound pressure at 10 m <sup>(2)</sup>		dB(A)	52	52	52	53	53	54	54	54	54
<b>Dimensions - Standard unit</b>											
Length		mm	2410				3604				
Width		mm	2253				2253				
Height		mm	2324				2324				
Unit + Buffer tank module option		mm	3604				4798				
<b>Operating weight<sup>(3)</sup></b>											
Standard unit		kg	1222	1265	1266	1395	1416	1875	1911	2080	2137
Unit + Low Noise option		kg	1305	1348	1349	1503	1524	2001	2037	2224	2281
Unit + Low Noise option + HP dual-pump hydraulic module		kg	1483	1526	1527	1681	1717	2197	2278	2465	2521
Unit + Low Noise option + HP dual-pump hydraulic module + water buffer tank module		kg	2442	2485	2486	2640	2676	3156	3237	3424	3480
<b>Compressors</b>											
Hermetic Scroll 48.3 r/s											
Circuit A			1	1	1	2	2	2	2	3	3
Circuit B			2	2	2	2	2	3	3	3	3
No. of power stages			3	3	3	4	4	5	5	6	6
<b>Refrigerant<sup>(3)</sup></b>											
R410A (GWP = 2088 following ARI4)											

- \* In accordance with standard EN14511-3:2013.  
 \*\* In accordance with standard EN14825:2016, average climate conditions.  
 \*\*\* 30 % brine solution  
 CA1 Cooling mode conditions: evaporator water inlet/outlet temperature 12 °C/7 °C, outdoor air temperature 35 °C, evaporator fouling factor 0 m<sup>2</sup>. kW/W  
 CA2 Cooling mode conditions: evaporator water inlet/outlet temperature 23 °C/18 °C, outdoor air temperature 35 °C, evaporator fouling factor 0 m<sup>2</sup>. kW/W  
**η<sub>s</sub> cool<sub>12/7°C</sub> & SEER<sub>12/7°C</sub>** Values in bold comply with Ecodesign Regulation (EU) No. 2016/2281 for Comfort application  
 SEPR<sub>12/7°C</sub> Values calculated according to EN14825:2016  
**SEPR<sub>-2/-8°C</sub>** Values in bold comply with Ecodesign Regulation (EU) No. 2015/1095 for Process application  
 NA Not authorised for the specific application for the EEC market  
 IPLV.SI Calculated as per AHRI standard 551-591 (SI).  
 (1) in dB ref=10<sup>-12</sup> W, 'A' weighted. Declared dual number noise emission values in accordance with ISO 4871 with an associated uncertainty of +/-3 dB(A). Measured in accordance with ISO 9614-1 and certified by Eurovent.  
 (2) In dB ref 20μPa, 'A' weighted. Declared dual-number noise emission values in accordance with ISO 4871 with an associated uncertainty of +/-3dB(A). For information, calculated from the sound power Lw(A).  
 (3) Values are guidelines only. Refer to the unit name plate.



Eurovent certified values

**TECHNICAL CHARACTERISTICS**

AQUACIAT <sup>POWER</sup> LD ST		602	650	750	800	1000	1100	1250	1350	1500
Circuit A	kg	8,4	10,9	10,9	12,6	13,1	14,7	15,4	20,3	21,1
	tCO <sub>2</sub> e	17,5	22,8	22,8	26,3	27,4	30,7	32,2	42,4	44,1
Circuit B	kg	12,25	12,6	12,6	12,7	13,1	20,2	20,2	20,4	22,2
	tCO <sub>2</sub> e	25,6	26,3	26,3	26,5	27,4	42,2	42,2	42,6	46,4
<b>Oil charge</b>										
	l/cp	6,9	6,9	6,9	6,9	6,9	6,9	6,9	6,9	6,9
<b>Control</b>		Connect Touch Control								
Minimum capacity	%	33%	33%	33%	25%	25%	20%	20%	17%	17%
<b>Air-cooled exchanger</b>		All-aluminium microchannel heat exchanger (MCHE)								
<b>Fans - Standard unit</b>										
Quantity		3	4	4	4	4	5	5	6	6
Maximum total air flow	l/s	13542	18056	18056	18056	18056	22569	22569	27083	27083
Maximum rotation speed	r/s	16	16	16	16	16	16	16	16	16
<b>Water type heat exchanger</b>		Dual-circuit plate heat exchanger								
Water volume	l	15	15	15	15	19	27	35	33	42
Max. water-side operating pressure without hydraulic module	kPa	1000	1000	1000	1000	1000	1000	1000	1000	1000
<b>Hydraulic module (option)</b>		Pump, Victaulic screen filter, relief valve, water and air vent valve, pressure sensors								
Pump		Centrifugal pump, monocell, 48.3 r/s, low- or high-pressure (as required), single or dual (as required)								
Expansion vessel volume (option)	l	50	50	50	50	50	80	80	80	80
Buffer tank volume (optional)	l	550	550	550	550	550	550	550	550	550
Max. water-side operating pressure with hydraulic module	kPa	400	400	400	400	400	400	400	400	400
<b>Water connections with/without hydraulic module</b>		Victaulic® type								
Connections	inch	3	3	3	3	3	4	4	4	4
External diameter	mm	88,9	88,9	88,9	88,9	88,9	114,3	114,3	114,3	114,3
<b>Casing paint</b>		Colour code RAL 7035/RAL 7024								

### TECHNICAL CHARACTERISTICS



AQUACIAT <sup>POWER</sup> LD HE			602	650	750	800	1000	1100	1250	1350	1500	1600	1750	2000		
<b>Cooling</b>																
<b>Standard unit</b> Full load performances*	CA1	Nominal capacity	kW	168	180	197	216	261	300	331	365	397	430	464	523	
		EER	kW/kW	3,04	3,12	2,98	2,97	2,90	2,97	2,92	2,95	2,90	2,94	2,90	2,90	
	CA2	Nominal capacity	kW	216	247	263	297	336	393	428	475	510	556	593	676	
		EER	kW/kW	3,6	3,89	3,59	3,7	3,37	3,53	3,4	3,47	3,37	3,45	3,34	3,38	
<b>Standard unit</b> Seasonal energy efficiency**	<b>SEER<sub>12/7°C</sub> Comfort low temp.</b>		<b>kWh/kWh</b>	<b>4,32</b>	<b>4,29</b>	<b>4,18</b>	<b>4,25</b>	<b>4,20</b>	<b>4,52</b>	<b>4,40</b>	<b>4,52</b>	<b>4,37</b>	<b>4,67</b>	<b>4,70</b>	<b>4,65</b>	
	<b>η<sub>s cool</sub> 12/7°C</b>		<b>%</b>	<b>170</b>	<b>169</b>	<b>164</b>	<b>167</b>	<b>165</b>	<b>178</b>	<b>173</b>	<b>178</b>	<b>172</b>	<b>184</b>	<b>185</b>	<b>183</b>	
	<b>SEPR<sub>12/7°C</sub> Process high temp.</b>		<b>kWh/kWh</b>	<b>5,43</b>	<b>5,61</b>	<b>5,32</b>	<b>5,56</b>	<b>5,16</b>	<b>5,60</b>	<b>5,24</b>	<b>5,62</b>	<b>5,32</b>	<b>5,50</b>	<b>5,38</b>	<b>5,26</b>	
<b>Unit + low temperature brine solution option</b> Seasonal energy efficiency**	<b>SEPR<sub>-2/-8°C</sub> Process medium temp.***</b>		<b>kWh/kWh</b>	<b>3,03</b>	<b>3,40</b>	<b>3,38</b>	<b>3,33</b>	<b>3,22</b>	<b>3,40</b>	<b>3,06</b>	<b>3,47</b>	<b>3,42</b>	NA	NA	NA	
Part Load integrated values			IPLV.SI	kW/kW	4,758	4,855	4,733	4,849	4,749	4,999	4,833	5,004	4,815	4,925	4,999	4,839
<b>Sound levels</b>																
<b>Standard unit</b>																
Sound power <sup>(1)</sup>			dB(A)	91	92	92	92	92	93	93	93	93	94	94	94	
Sound pressure at 10 m <sup>(2)</sup>			dB(A)	59	60	60	60	60	60	60	61	61	62	62	62	
<b>Unit + Low Noise option</b>																
Sound power <sup>(1)</sup>			dB(A)	89	90	90	90	90	91	91	92	92	93	93	93	
Sound pressure at 10 m <sup>(2)</sup>			dB(A)	57	58	58	58	58	59	59	60	60	60	60	60	
<b>Unit + Xtra Low Noise option</b>																
Sound power <sup>(1)</sup>			dB(A)	84	84	84	85	85	86	86	86	86	87	87	87	
Sound pressure at 10 m <sup>(2)</sup>			dB(A)	52	52	52	53	53	54	54	54	54	55	54	54	
<b>Dimensions - Standard unit</b>																
Length			mm	2410			3604			4797						
Width			mm	2253			2253			2253						
Height			mm	2324			2324			2324						
Unit + Buffer tank module option			mm	3604			4798			5991						
<b>Operating weight<sup>(3)</sup></b>																
Standard unit			kg	1258	1302	1302	1431	1453	1912	1947	2116	2174	2614	2631	2842	
Unit + Low Noise option			kg	1341	1385	1385	1539	1561	2038	2073	2260	2318	2776	2793	3022	
Unit + Low Noise option + HP dual-pump hydraulic module			kg	1519	1563	1563	1717	1754	2234	2314	2501	2558	3057	3074	3339	
Unit + Low Noise option + HP dual-pump hydraulic module + Buffer tank module			kg	2478	2522	2522	2676	2713	3193	3273	3460	3517	4016	4033	4298	
<b>Compressors</b>			Hermetic Scroll 48.3 r/s													
Circuit A				1	1	1	2	2	2	2	3	3	3	3	4	
Circuit B				2	2	2	2	2	3	3	3	3	4	4	4	
No. of power stages				3	3	3	4	4	5	5	6	6	7	7	8	

\* In accordance with standard EN14511-3:2013.  
 \*\* In accordance with standard EN14825:2016, average climate conditions.  
 \*\*\* With 30 % brine solution  
 CA1 Conditions in cooling mode: Evaporator water inlet/outlet temperature 12 °C/7 °C, outdoor air temperature 35°C, evaporator fouling factor 0 m<sup>2</sup>. kW/W.  
 CA2 Cooling mode conditions: evaporator water inlet/outlet temperature 23 °C/18 °C, outdoor air temperature 35 °C, evaporator fouling factor 0 m<sup>2</sup>. kW/W.  
 η<sub>s cool</sub> 12/7°C & SEER<sub>12/7°C</sub> **Values in bold comply with Ecodesign Regulation (EU) No. 2016/2281 for Comfort application**  
 SEPR<sub>12/7°C</sub> **Values in bold comply with Ecodesign Regulation (EU) No. 2016/2281 for Process application**  
 SEPR<sub>-2/-8°C</sub> **Values in bold comply with Ecodesign Regulation (EU) No. 2015/1095 for Process application**  
 NA Not authorised for the specific application for the EEC market.  
 IPLV.SI Calculated as per AHRI standard 551-591 (SI).  
 (1) in dB ref=10<sup>-(12)</sup> W, 'A' weighted. Declared dual-number noise emission values in accordance with ISO 4871 with an associated uncertainty of +/-3dB(A). Measured in accordance with ISO 9614-1 and certified by Eurovent.  
 (2) In dB ref 20μPa, 'A' weighted. Declared dual-number noise emission values in accordance with ISO 4871 with an associated uncertainty of +/-3dB(A). For information, calculated from the sound power level Lw(A).  
 (3) Values are guidelines only. Refer to the unit name plate.



Eurovent certified values

**TECHNICAL CHARACTERISTICS**

AQUACIAT <sup>POWER</sup> LD HE		602	650	750	800	1000	1100	1250	1350	1500	1600	1750	2000
<b>Refrigerant<sup>(3)</sup></b>		R410A (GWP = 2088 following ARI4)											
Circuit A	kg	8,40	10,90	10,90	12,60	13,10	14,70	15,40	20,30	21,10	23,50	23,50	26,75
	tCO <sub>2</sub> e	17,5	22,8	22,8	26,3	27,4	30,7	32,2	42,4	44,1	49,1	49,1	55,9
Circuit B	kg	12,25	12,60	12,60	12,70	13,10	20,20	20,20	20,40	22,20	26,70	26,80	26,95
	tCO <sub>2</sub> e	25,6	26,3	26,3	26,5	27,4	42,2	42,2	42,6	46,4	55,7	56,0	56,3
<b>Oil charge</b>													
	l/cp	6,9	6,9	6,9	6,9	6,9	6,9	6,9	6,9	6,9	6,9	6,9	6,9
<b>Control</b>		Connect Touch Control											
Minimum capacity	%	33%	33%	33%	25%	25%	20%	20%	17%	17%	14%	14%	13%
<b>Air-cooled exchanger</b>		All-aluminium microchannel heat exchanger (MCHE)											
<b>Fans - Standard unit</b>													
Quantity		3	4	4	4	4	5	5	6	6	7	7	8
Maximum total air flow	l/s	13542	18056	18056	18056	18056	22569	22569	27083	27083	31597	31597	36111
Maximum rotation speed	r/s	16	16	16	16	16	16	16	16	16	16	16	16
<b>Water type heat exchanger</b>		Dual-circuit plate heat exchanger											
Water volume	l	15	15	15	15	19	27	35	33	42	44	47	53
Max. water-side operating pressure without hydraulic module	kPa	1000	1000	1000	1000	1000	1000	1000	1000	1000	1000	1000	1000
<b>Hydraulic module (option)</b>		Pump, Victaulic screen filter, relief valve, water and air vent valve, pressure sensors											
Pump		Centrifugal pump, monocell, 48.3 r/s, low- or high-pressure (as required), single or dual (as required)											
Expansion vessel volume (option)	l	50	50	50	50	50	80	80	80	80	80	80	80
Buffer tank volume (optional)	l	550	550	550	550	550	550	550	550	550	550	550	550
Max. water-side operating pressure with hydraulic module	kPa	400	400	400	400	400	400	400	400	400	400	400	400
<b>Water connections with/without hydraulic module</b>		Victaulic® type											
Connections	inch	3	3	3	3	3	4	4	4	4	4	4	4
External diameter	mm	88,9	88,9	88,9	88,9	88,9	114,3	114,3	114,3	114,3	114,3	114,3	114,3
<b>Casing paint</b>		Colour code RAL 7035/RAL 7024											



## ELECTRICAL DATA

### Basic unit (excluding pump)

AQUACIAT <sup>POWER</sup> LD ST		602	650	750	800	1000	1100	1250	1350	1500
<b>Power circuit</b>										
Nominal voltage	V-ph-Hz	400 - 3 - 50								
Voltage range	V	360 - 440								
Control circuit supply		24 V via internal transformer								
<b>Nominal unit current draw<sup>(1)</sup></b>										
Circuit A&B	A	100	110	124	133	161	180	201	221	242
<b>Max. operating input power<sup>(2)</sup></b>										
Circuit A&B	kW	80	88	99	107	129	145	161	177	194
<b>Unit power factor at maximum power<sup>(2)</sup></b>										
Circuit A&B		0,88	0,87	0,87	0,88	0,88	0,88	0,88	0,88	0,88
<b>Maximum unit current draw (Un-10%)<sup>(3)</sup></b>										
Circuit A&B	A	144	158	176	192	230	259	288	317	345
<b>Max. current draw (Un)<sup>(4)</sup></b>										
Circuit A&B - Standard unit	A	133	146	163	177	212	239	266	292	319
Circuit A&B - Unit + Power factor corrector option	A	100	110	125	133	163	181	204	222	244
<b>Maximum start-up current, standard unit (Un)<sup>(5)</sup></b>										
Circuit A&B	A	307	356	374	352	423	450	476	503	529
<b>Maximum start-up current, unit with soft starter (Un)<sup>(5)</sup></b>										
Circuit A&B	A	261	283	300	305	349	376	403	429	456

(1) Conditions equivalent to the standardised Eurovent conditions (water exchanger water inlet/outlet temperature = 12°C/7°C, outdoor air temperature = 35°C).

(2) Power input, compressors + fans, at the unit operating limits (saturated suction temperature: 15 °C, saturated condensation temperature 68.3 °C) and nominal voltage of 400 V (data given on the unit's nameplate).

(3) Maximum unit operating current at maximum unit power input and 360 V.

(4) Maximum unit operating current at maximum unit input power and 400 V (data given on the unit's name plate).

(5) Maximum instantaneous starting current at the operating limits (maximum operating current of the smallest compressor(s) + current of the fan(s) + locked rotor current of the largest compressor).

Fan motor electrical data at Eurovent equivalent conditions and motor ambient air temperature of 50 °C at 400 V: current 3.8 A, starting current 20 A, input power: 1.75 kW.

AQUACIAT <sup>POWER</sup> LD HE		602	650	750	800	1000	1100	1250	1350	1500	1600	1750	2000
<b>Power circuit</b>													
Nominal voltage	V-ph-Hz	400 - 3 - 50											
Voltage range	V	360 - 440											
Control circuit supply		24 V via internal transformer											
<b>Nominal unit current draw<sup>(1)</sup></b>													
Circuit A&B	A	97	107	121	130	158	176	197	216	237	255	276	316
<b>Max. operating input power<sup>(2)</sup></b>													
Circuit A&B	kW	81	88	99	108	129	145	162	178	194	210	226	259
<b>Unit power factor at maximum power<sup>(2)</sup></b>													
Circuit A&B		0,88	0,88	0,88	0,88	0,88	0,88	0,88	0,88	0,88	0,88	0,88	0,88
<b>Unit max. operating current (Un-10%)<sup>(3)</sup></b>													
Circuit A&B	A	142	154	173	189	227	255	284	312	340	369	397	454
<b>Max. current draw (Un)<sup>(4)</sup></b>													
Circuit A&B - Standard unit	A	131	142	160	174	209	235	262	287	314	340	366	419
Circuit A&B - Unit + Power factor correction option	A	98	108	123	131	161	178	201	219	241	259	281	321
<b>Maximum start-up current, standard unit (Un)<sup>(5)</sup></b>													
Circuit A&B	A	305	353	371	349	420	446	472	498	525	550	577	629
<b>Maximum start-up current, unit with soft starter (Un)<sup>(5)</sup></b>													
Circuit A&B	A	259	279	297	302	346	372	399	424	451	477	503	556

(1) Conditions equivalent to the standardised Eurovent conditions (water exchanger water inlet/outlet temperature = 12°C/7°C, outdoor air temperature = 35°C).

(2) Power input, compressors + fans, at the unit operating limits (saturated suction temperature: 15 °C, saturated condensation temperature: 68.3 °C) and nominal voltage of 400 V (data given on the unit's name plate).

(3) Maximum unit operating current at maximum unit power input and 360 V.

(4) Maximum unit operating current at maximum unit input power and 400 V (data given on the unit's name plate).

(5) Maximum instantaneous starting current at the operating limits (maximum operating current of the smallest compressor(s) + current of the fan(s) + locked rotor current of the largest compressor).

Fan motor electrical data reported upstream of the variable speed drive at Eurovent equivalent conditions and motor ambient air temperature of 50°C at 400 V: current 3.0 A; starting current 20 A; power input: 1.75 kW.

## ELECTRICAL DATA

### Short circuit current withstand capability (TN system<sup>(1)</sup>)

AQUACIAT <sup>POWER</sup> LD ST/HE	602	650	800	900	902	1000	1150	1200	1400	1600	1800	2000
<b>Value without upstream protection</b>												
Short time (1s) assigned current - I <sub>cw</sub> - kA eff	8	8	8	8	8	8	15	15	15	15	20	20
Allowable peak assigned current - I <sub>pk</sub> - kA pk	30	30	30	30	30	30	65	65	65	65	80	80
<b>Value with upstream protection</b>												
Protection type: Fuse												
Rated conditional short circuit current I <sub>cc</sub> or I <sub>cf</sub> - kA eff	50	50	50	50	50	50	50	50	50	50	50	50
Assigned gL/gG fuses	200	200	200	250	250	250	315	315	400	400	630	630

(1) Type of system earthing

### PARTIAL RECOVERY WITH DESUPERHEATER



The AQUACIAT<sup>POWER</sup> range may be equipped as an option with an energy recovery function using a desuperheater.

Heat from gases released by the compressors is recovered directly by a type of heat exchanger called a desuperheater located on the unit to produce free, additional hot water.

This optional configuration requires assembly in our factories and is by order only.

#### ■ Refrigerant circuit schematic diagram

This refrigeration diagram illustrates a unit with a desuperheater on each refrigerating circuit. For heat recovery to be possible, the unit must be operating. For the same cooling capacity, the desuperheater provides a source of free hot water and lowers the unit's electrical power consumption.

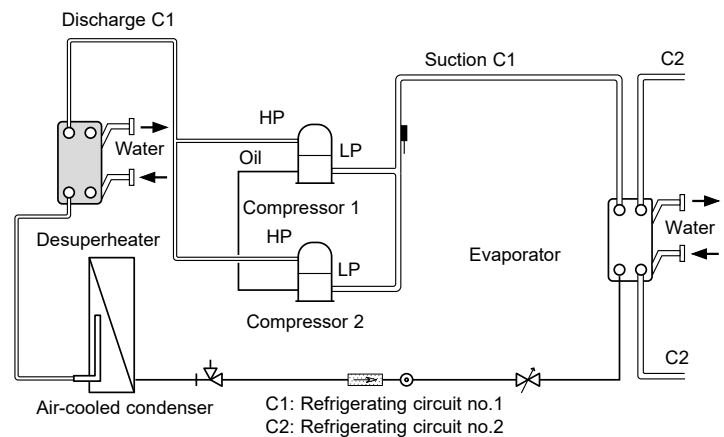

#### ■ Hydraulic connections: configuration and precautions

The hydraulic supply for each desuperheater is delivered in parallel. In order to ensure that the unit can start and operate under the correct conditions, the desuperheater circuit water loop must be as short as possible and be able to increase quickly in temperature. The minimum desuperheater water inlet temperature must be 25°C. It may require the use of a three-way valve with its controller and a sensor controlling the minimum water inlet temperature.

#### Note:

The water loop for the desuperheater circuit must include an expansion vessel and a valve. Special attention should be paid when selecting the expansion vessel as the recovery water circuit can reach 120°C if the pump is turned off or if no hot water is consumed.

#### ■ Operating limits

Desuperheater		Minimum	Maximum
Water inlet temperature at start-up	°C	25	60 (602 to 2000) / 75 (2100 to 2800)
Leaving water temperature during operation	°C	30	80
Air-cooled condenser		Minimum	Maximum
Outdoor air temperature during operation	°C	0*	46

\* - 20 °C with the winter operation option for the ST version  
 - 20 °C as standard for the HE version

## PARTIAL RECOVERY WITH DESUPERHEATER

### ■ Technical characteristics

AQUACIAT <sup>POWER</sup> LD ST/HE		602	650	750	800	1000	1100	1250	1350	1500	1600	1750	2000
<b>Partial heat recovery on the A/B circuits</b>		Plate heat exchanger											
Water volume circuits A/B	l	2/3.75	2/3.75	2/3.75	3.75/3.75	3.75/3.75	3.75/5.5	3.75/5.5	5.5/5.5	5.5/5.5	5.5/7.5	5.5/7.5	7.5/7.5
Maximum operating pressure, water side	kPa	1000	1000	1000	1000	1000	1000	1000	1000	1000	1000	1000	1000
<b>Refrigerant</b>		R410A											
Circuit A1	kg	9,1	11,9	11,9	14,3	13,6	15,0	16,9	22,8	21,4	26,3	23,7	27,3
	tCO <sub>2</sub> e	19,1	26,9	26,9	30,0	28,4	31,3	35,3	47,6	44,7	54,9	49,6	57,0
Circuit B1	kg	13,5	14,3	13,3	14,5	13,6	22,8	21,1	20,9	22,4	27,4	27,3	27,5
	tCO <sub>2</sub> e	28,1	30,0	27,7	30,2	28,4	47,6	44,1	43,7	46,8	57,1	57,1	57,4
<b>Water connections</b>		Victaulic®											
Connection	inch	2"	2"	2"	2"	2"	2"	2"	2"	2"	2"	2"	2"
External diameter	mm	60,3	60,3	60,3	60,3	60,3	60,3	60,3	60,3	60,3	60,3	60,3	60,3
<b>AQUACIAT<sup>POWER</sup> LD ST</b>													
<b>Operating weight<sup>(1)</sup></b>													
Unit + Partial heat recovery option	kg	1269	1310	1311	1446	1467	1932	1968	2143	2201	2626	2643	2849
Unit + Low Noise + Partial heat recovery option	kg	1352	1393	1394	1554	1575	2058	2094	2287	2344	2788	2805	3029
Unit + Low Noise + HP dual-pump hydraulic module + Partial heat recovery option	kg	1491	1533	1533	1693	1729	2218	2298	2491	2548	3032	3049	3309
<b>AQUACIAT<sup>POWER</sup> LD HE</b>													
<b>Operating weight<sup>(1)</sup></b>													
Unit + Partial heat recovery option	kg	1305	1347	1347	1482	1504	1969	2004	2180	2237	2683	2700	2915
Unit + Low Noise + Partial heat recovery option	kg	1388	1430	1430	1590	1612	2095	2130	2323	2381	2845	2862	3095
Unit + Low Noise + HP dual-pump hydraulic module + Partial heat recovery option	kg	1527	1569	1569	1729	1766	2254	2334	2528	2584	3089	3106	3375

### ■ Performance levels

AQUACIAT <sup>POWER</sup> LD ST/HE		602	650	750	800	1000	1100	1250	1350	1500	1600	1750	2000
Total heating capacity	kW	223	239	264	289	352	401	444	489	534	577	624	704
Recovery capacity (45-55)	kW	49,8	53,3	59,6	69,1	78,9	108,1	120,5	132,4	144,7	156,5	169,6	191,4
% recovery	%	22%	22%	23%	24%	22%	27%	27%	27%	27%	27%	27%	27%
Water flow rate	l/s	1,2	1,3	1,4	1,7	1,9	2,6	2,9	3,2	3,5	3,8	4,1	0,0
Pressure drop, water	kPa	4,6	5,2	6,4	8,4	10,7	10,9	13,4	8,4	9,9	11,5	13,3	16,8
Recovery capacity (50-60)	kW	42,9	45,8	51,2	57,4	68	89,9	100,3	110,4	120,6	125,6	136	153,6
% recovery	%	19%	19%	19%	20%	19%	22%	23%	23%	23%	22%	22%	22%
Water flow rate	l/s	1,0	1,1	1,2	1,4	1,7	2,2	2,4	2,7	2,9	3,0	3,3	3,7
Pressure drop, water	kPa	3,4	3,9	4,7	5,8	8,0	7,7	9,4	5,8	6,9	7,4	8,6	10,9
Recovery capacity (55-65)	kW	33,6	35,9	40,2	45,4	53,3	70,7	78,8	86,6	94,6	97,9	106,1	119,7
% recovery	%	15%	15%	15%	16%	15%	18%	18%	18%	18%	17%	17%	17%
Water flow rate	l/s	0,8	0,9	1,0	1,1	1,3	1,7	1,9	2,1	2,3	2,4	2,6	2,9
Pressure drop, water	kPa	2,1	2,4	3	3,7	5	4,8	5,9	3,6	4,3	4,6	5,3	6,7

## XTRA FAN OPERATING PRESSURE VENTILATION

HE version models in sizes 602 to 2000 can be equipped with the optional XTRAFAN operating pressure ventilation.

### ■ Features

The XTRAFAN offers a wide range of functions, making a whole host of flexible installation conditions possible, such as:

- The option of installation in a confined space, for example on a terrace surrounded by walls, where only an air supply with static pressure of between 100 and 200 pascals within a duct enables use without recycling or mixing of air at the condenser intake.
- Installation in an urban area in which noise is a particular issue, where operation is only possible by adapting a sound trap to the air supply.
- A self-adjusting variable speed function which allows "all-season" cooling, fully secured for industrial processes, including during harsh winter conditions with an external temperature of  $-20^{\circ}\text{C}$ .
- The freedom to precisely adjust the ventilation speed on-site to what is "strictly necessary" to obtain the optimum air supply pressure, or the maximum acceptable sound limit for the site on which the unit is located.
- An improvement in the EER and electrical consumption for the unit, in direct proportion to the load required by the installation.

The various performances (cooling capacity, input power, energy efficiency) depend on the rotation speed of the fans, and therefore on the desired operating pressure in the duct:

- At an operating pressure of between 0 and 100 Pa, the machine performances are barely affected.
- At an operating pressure of between 100 and 200 Pa, the machine performances may be significantly affected, particularly according to the air and water temperature conditions.

The sound level at the duct outlet and the level radiated around the machine depends on the operating pressure.

Refer to the selection tool to evaluate the estimated impact of the ducting system on the machine's operating conditions

### ■ Precautions for installation

If an air discharge duct is installed on site, its weight must not be supported by the roof of the unit. Each fan must be connected independently.

The duct must be connected to the unit using a flexible supply air sleeve, included in the option.

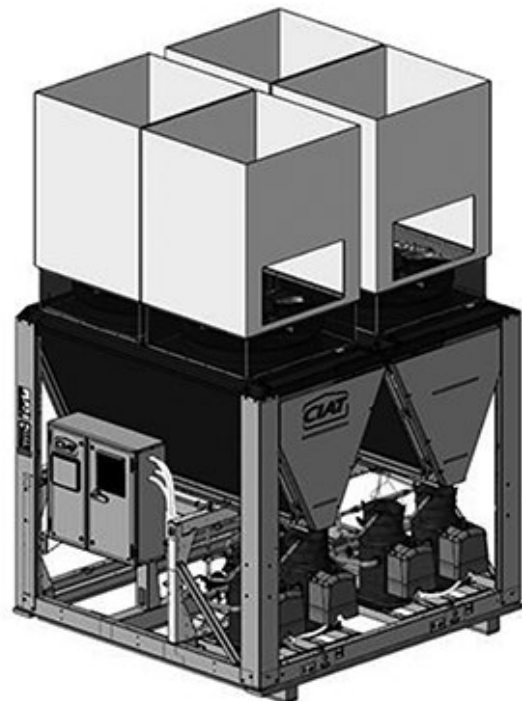

## SHELL AND TUBE WATER TYPE HEAT EXCHANGER

The units equipped with this option have a shell and tube dry expansion evaporator instead of the brazed-plate evaporator. installations or specific applications requiring a more powerful "evaporator" circuit.

This type of configuration is particularly suited to industrial

### ■ Technical characteristics

AQUACIAT <sup>POWER</sup> LD ST/HE + shell and tube exchanger option		602	650	750	800	1000
<b>Operating weight<sup>(1)</sup></b>						
Unit	kg	1563	1606	1607	1736	1736
Unit + Low Noise option	kg	1646	1689	1690	1844	1844
Unit + Low Noise option + HP dual-pump hydraulic module	kg	1824	1867	1868	2022	2037
Unit + Low Noise option + HP dual-pump hydraulic module + water buffer tank module	kg	2783	2826	2827	2981	2996
<b>AQUACIAT<sup>POWER</sup> LD HE + shell and tube exchanger option</b>						
<b>Operating weight<sup>(1)</sup></b>						
Unit	kg	1599	1643	1643	1772	1773
Unit + Low Noise option	kg	1682	1726	1726	1880	1881
Unit + Low Noise option + HP dual-pump hydraulic module	kg	1860	1904	1904	2058	2074
Unit + Low Noise option + HP dual-pump hydraulic module + water buffer tank module	kg	2819	2863	2863	3017	3033
<b>AQUACIAT<sup>POWER</sup> LD ST/HE + shell and tube exchanger option</b>						
<b>Refrigerant<sup>(1)</sup></b>						
R410A						
Circuit A	kg	9,80	12,60	12,60	13,60	13,60
	tCO <sub>2</sub> e	20,5	26,3	26,3	28,4	28,4
Circuit B	kg	13,80	13,80	13,80	13,80	13,80
	tCO <sub>2</sub> e	28,8	28,8	28,8	28,8	28,8
<b>Water type heat exchanger</b>						
Water volume	l	92	92	92	92	92
Max. water-side operating pressure without hydraulic module	kPa	1000	1000	1000	1000	1000
<b>Water connections without hydraulic module</b>						
Victaulic® type						
Connections	inch	4	4	4	4	4
External diameter	mm	114,3	114,3	114,3	114,3	114,3
<b>Water connections with hydraulic module</b>						
Victaulic® type						
Connections	inch	3	3	3	3	3
External diameter	mm	88,9	88,9	88,9	88,9	88,9

(1) Values are guidelines only. Refer to the unit nameplate.

### ■ Water flow rate range, without hydraulic module

AQUACIAT <sup>POWER</sup> LD ST / LD HE		602	650	800	900	902
Shell and tube evaporator	Min <sup>(1)</sup> / max <sup>(2)</sup> water exchanger flow rate without hydronic module (l/s)	2,9 / 18,3	3,2 / 18,3	3,6 / 18,3	3,8 / 18,3	4,6 / 18,3

(1) Minimum flow rate for maximum permitted water temperature difference conditions (10° C)

(2) Maximum flow rate for a pressure drop of 100 kPa in the shell and tube exchanger

For units with hydraulic module, the flow rate range depends on the type of pump. Refer to the section "Water exchanger min. water volume and flow rate" for units with the standard exchanger.

## SHELL AND TUBE WATER TYPE HEAT EXCHANGER

### ■ Water pressure drop

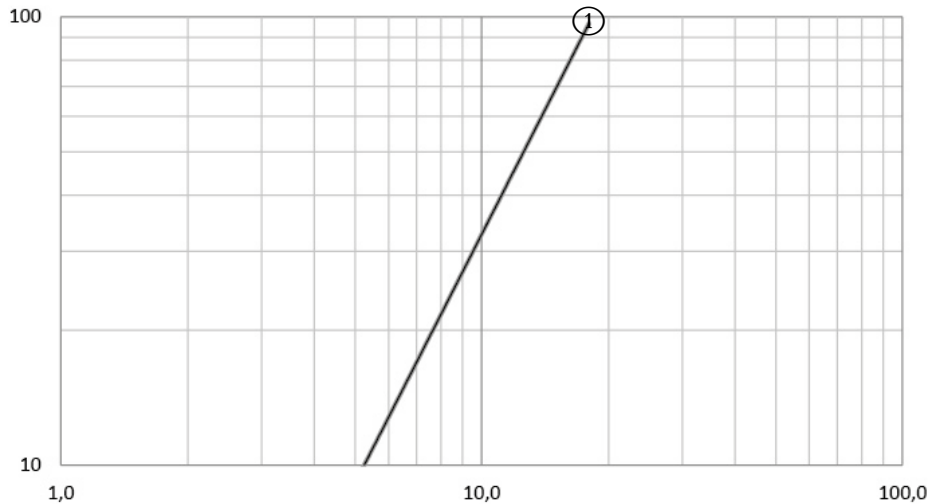

① LD ST HE 602 - 1000

For units with hydraulic module, the available static pressure depends on the type of pump. Refer to the section "Available static system pressure" for units with the standard exchanger.

### ■ Refrigerant charge for the combination of shell and tube water type heat exchanger and low-temperature brine solution options

AQUACIAT <sup>POWER</sup> LD ST/HE + shell and tube exchanger option + low temperature brine solution option		602	650	750	800	1000
<b>Refrigerant<sup>(1)</sup></b>		R410A				
Circuit A	kg	9,80	12,10	12,10	13,10	13,10
	tCO <sub>2</sub> e	20,5	25,3	25,3	27,4	27,4
Circuit B	kg	13,30	13,30	13,30	13,30	13,30
	tCO <sub>2</sub> e	27,8	27,8	27,8	27,8	27,8

(1) Values are guidelines only. Refer to the unit nameplate.

### ■ Operating range

The operating range for the unit with the shell and tube water type heat exchanger option is similar to that of the standard unit for most configurations.

However, in combination with brine options, the following limits must be respected:

- Medium-temperature brine solution option, the water outlet temperature for the shell and tube exchanger is limited to 0 °C (same as the std exchanger)
- Low-temperature brine solution option, the water outlet temperature for the shell and tube exchanger is limited to -12 °C

### INTELLIGENTLY-DESIGNED ACOUSTICS

To comply with the various restrictions on integration, the AQUACIAT<sup>POWER</sup> has three sound finish levels enabling it to be easily integrated into a number of zones without causing disruption to users or their neighbours.

#### ■ Basic version

The distinguishing feature of the AQUACIAT<sup>POWER</sup> range is its rigorous design incorporating "noiseless" assembly techniques to reduce vibrations and sources of noise:

- New generation scroll compressors with a continuous scrolling motion to lessen vibrations
- Compressor structure separated from the unit by anti-vibration mounts
- Pipes separated from the unit structure
- Fans made from a synthetic material, with aerodynamic blades offering an optimised profile. Optimised air coil-fan pairing which is the result of many hours of thermal and acoustic studies in our Research and Innovation Centre. Each fan is equipped with an air current rectifier deflector which ensures a linear flow of air with no turbulence, whilst reducing recirculation and keeping the acoustic spectrum within a pleasant range.
- The Connect Touch controller automatically adjusts the fan air flow rate according to the outdoor air temperature and the unit's load rate which enables the sound level to be significantly reduced, particularly at night, mid-season, morning and evening, which totals more than 75% of the time the unit is used.

#### ■ Low Noise option

In this version, in addition to the basic equipment, the compressors are fitted inside soundproofed boxes lined with absorbent material to limit the sound level emitted by the machine.

#### ■ Xtra Low Noise option

In this version, the compressors are housed in sound boxes identical to those in the Low Noise version and the fan rotation speed is reduced whilst ensuring the output and thermal performance remain optimised.



#### ■ Night mode

The AQUACIAT<sup>POWER</sup> has a Night Mode enabling the sound level to be limited at night or when the building is unoccupied (according to the user programming) by controlling the output and the fan rotation speed.

#### ■ Acoustic signature

As important as the sound power level, the acoustic signature reflects the noise disturbance generated by the unit.

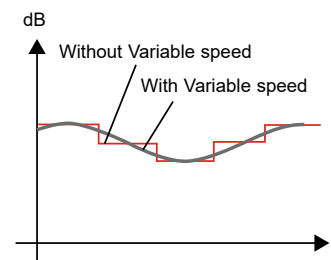
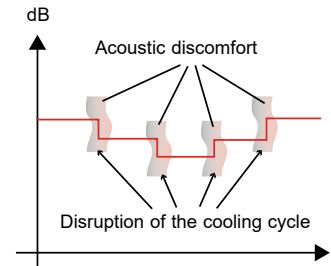

The AQUACIAT<sup>POWER</sup> HE series has AC-type variable-speed motors + external speed regulator on the fan motor assemblies as standard.

AQUACIAT<sup>POWER</sup> ST series units equipped as an option with variable speed motors (all-season operation) have one variable speed fan motor per refrigerant circuit.

The variable speed control can be used to soft start the fans. It avoids the increases in noise linked to the on/off sequences, thereby improving the unit's acoustic signature.

Similarly, the installation of a variable speed pump enables the sound level of the pump function to be reduced by adjusting the pump speed to what is strictly necessary. The soft start improves the signature and reduces nuisance noise.

With all these benefits and its three acoustic finish levels (Standard, Low Noise and Xtra Low Noise), the AQUACIAT<sup>POWER</sup> can be integrated into any site, ensuring any constraints in terms of the sound environment can be met.



## SOUND LEVELS

### Standard ST - High Efficiency HE versions

#### ■ Sound power levels ref $10^{-12}$ W $\pm$ 3 dB (L<sub>w</sub>)

At nominal EN 14511-3: 2013 operating conditions in cooling mode

AQUACIAT <sup>POWER</sup> LD ST/HE	SOUND POWER LEVEL SPECTRUM (dB)						Overall power level dB(A)
	125 Hz	250 Hz	500 Hz	1000 Hz	2000 Hz	4000 Hz	
602	92	89	90	86	81	77	91
650	93	90	91	87	81	78	92
750	93	90	91	87	81	78	92
800	93	91	91	87	82	78	92
1000	93	91	91	87	82	78	92
1100	93	91	92	88	82	79	93
1250	93	91	92	88	82	79	93
1350	94	92	92	89	83	79	93
1500	94	92	92	89	83	79	93
1600	95	92	93	89	84	80	94
1750	95	92	93	89	84	80	94
2000	95	92	93	89	84	80	94

#### ■ Sound pressure levels ref $2 \times 10^{-5}$ Pa $\pm$ 3 dB (L<sub>p</sub>)

Measurement conditions: free field, 10 metres from machine, 1.50 metres above floor level, directivity 2

AQUACIAT <sup>POWER</sup> LD ST/HE	SOUND PRESSURE SPECTRUM (dB)						Overall pressure level dB(A)
	125 Hz	250 Hz	500 Hz	1000 Hz	2000 Hz	4000 Hz	
602	60	57	58	55	49	45	59
650	61	58	59	55	49	46	60
750	61	58	59	55	49	46	60
800	61	59	59	55	50	46	60
1000	61	59	59	55	50	46	60
1100	61	59	59	56	50	46	60
1250	61	59	59	56	50	46	60
1350	62	60	60	56	51	47	61
1500	62	60	60	56	51	47	61
1600	62	60	61	57	51	48	62
1750	62	60	61	57	51	48	62
2000	62	60	61	57	51	48	62

**NB:** Sound pressure levels depend on the installation conditions of each system. As such, the levels listed here are given for information only. Only the sound power levels are comparable and certified.

## SOUND LEVELS

### Standard ST - High Efficiency HE LOW NOISE option versions

#### ■ Sound power levels ref $10^{-12}$ W $\pm 3$ dB (L<sub>w</sub>)

At nominal EN 14511-3: 2013 operating conditions in cooling mode

AQUACIAT <sup>POWER</sup> LD ST/HE	SOUND POWER LEVEL SPECTRUM (dB)						Overall power level dB(A)
	125 Hz	250 Hz	500 Hz	1000 Hz	2000 Hz	4000 Hz	
602	91	88	87	85	79	76	89
650	92	89	88	86	80	77	90
750	92	89	88	86	80	77	90
800	92	89	88	86	80	77	90
1000	92	89	88	86	80	77	90
1100	93	90	89	87	81	78	91
1250	93	90	89	87	81	78	91
1350	94	91	90	88	82	79	92
1500	94	91	90	88	82	79	92
1600	95	92	91	88	83	80	93
1750	95	92	91	88	83	80	93
2000	95	92	91	88	83	80	93

#### ■ Sound pressure levels ref $2 \times 10^{-5}$ Pa $\pm 3$ dB (L<sub>p</sub>)

Measurement conditions: free field, 10 metres from machine, 1.50 metres above floor level, directivity 2

AQUACIAT <sup>POWER</sup> LD ST/HE	SOUND PRESSURE SPECTRUM (dB)						Overall pressure level dB(A)
	125 Hz	250 Hz	500 Hz	1000 Hz	2000 Hz	4000 Hz	
602	59	56	55	53	47	44	57
650	60	57	56	54	48	45	58
750	60	57	56	54	48	45	58
800	60	57	56	54	48	45	58
1000	60	57	56	54	48	45	58
1100	61	58	57	55	49	46	59
1250	61	58	57	55	49	46	59
1350	62	59	58	55	50	47	60
1500	62	59	58	55	50	47	60
1600	62	59	58	56	51	47	60
1750	62	59	58	56	50	47	60
2000	62	59	58	55	50	47	60

**NB:** Sound pressure levels depend on the installation conditions of each system. As such, the levels listed here are given for information only. Only the sound power levels are comparable and certified.

## SOUND LEVELS

### Standard ST - High Efficiency HE XTRA LOW NOISE option versions

#### ■ Sound power levels ref $10^{-12}$ W $\pm 3$ dB (L<sub>w</sub>)

Nominal EN 14511-3: 2013 operating conditions in cooling mode

AQUACIAT <sup>POWER</sup> LD ST/HE	SOUND POWER LEVEL SPECTRUM (dB)						Overall power level dB(A)
	125 Hz	250 Hz	500 Hz	1000 Hz	2000 Hz	4000 Hz	
602	84	81	82	79	77	72	84
650	84	81	82	79	77	71	84
750	84	81	82	79	77	71	84
800	85	82	83	80	78	73	85
1000	85	82	83	80	78	73	85
1100	86	83	84	81	79	74	86
1250	86	83	84	81	79	74	86
1350	86	83	84	81	79	74	86
1500	86	83	84	81	79	74	86
1600	87	84	85	82	80	75	87
1750	87	84	85	82	80	75	87
2000	87	84	85	82	80	75	87

#### ■ Sound pressure levels ref $2 \times 10^{-5}$ Pa $\pm 3$ dB (L<sub>p</sub>)

Measurement conditions: free field, 10 metres from machine, 1.50 metres above floor level, directivity 2

AQUACIAT <sup>POWER</sup> LD ST/HE	SOUND PRESSURE SPECTRUM (dB)						Overall pressure level dB(A)
	125 Hz	250 Hz	500 Hz	1000 Hz	2000 Hz	4000 Hz	
602	52	49	50	47	45	40	52
650	52	49	50	47	45	39	52
750	52	49	50	47	45	39	52
800	53	50	51	48	46	41	53
1000	53	50	51	48	46	41	53
1100	53	51	51	49	47	42	54
1250	53	51	51	49	47	42	54
1350	53	51	51	49	47	42	54
1500	53	51	51	49	47	42	54
1600	54	51	52	50	47	42	55
1750	54	51	52	49	47	42	54
2000	54	51	52	49	47	42	54

**NB:** Sound pressure levels depend on the installation conditions of each system. As such, the levels listed here are given for information only. Only the sound power levels are comparable and certified.

## SYSTEM WATER VOLUME - EVAPORATOR WATER FLOW RATE

The Connect Touch controller is equipped with anticipation logic making it highly flexible in adjusting operation to parameter drift, particularly on hydraulic systems with low water volumes. By adjusting compressor running times, it prevents short-cycle protection cycles from starting and, in most cases, eliminates the need for a buffer tank.

**Note** The minimum volumes of chilled water are calculated for EUROVENT rated conditions:

- Chilled water temperature = 12°C/7°C
- Condenser air inlet temperature = 35°C

This value is applicable for most air conditioning applications (unit with fan coil units).

**Note:**

For installations running with a low volume of water (assembly with air handling unit) or for industrial processes, the buffer tank is a required component.

AQUACIAT <sup>POWER</sup> LD ST/HE	602	650	750	800	1000	1100	1250	1350	1500	1600	1750	2000	
Minimum system water volume, air conditioning application (litres)	420	451	494	539	654	750	827	914	993	1076	1159	1306	
Minimum system water volume, industrial process application (litres)	1091	1173	1283	1401	1699	1949	2150	2375	2582	2796	3014	3396	
Min <sup>(1)</sup> /max <sup>(2)</sup> water type heat exchanger flow rate without hydraulic module (l/s)	2,9 / 17,5	3,2 / 17,5	3,6 / 17,5	3,8 / 17,5	4,6 / 21,8	5,2 / 29,8	5,9 / 35,2	6,3 / 33,8	7,1 / 38,9	7,6 / 40,4	8,2 / 41,6	9,4 / 43,4	
Water exchanger flow rate with low pressure hydraulic module (l/s)	Single min <sup>(3)</sup> / max	2,8 / 12,2	2,8 / 12,2	2,8 / 12,2	2,8 / 12,2	4 / 14,3	3,1 / 20,2	3,4 / 20,2	3,7 / 20,2	9,5 / 25	9,5 / 25	9,5 / 25	5,4 / 26,6
	Dual min <sup>(3)</sup> / max	3,2 / 10,3	3,2 / 10,3	2,5 / 12,2	2,5 / 12,2	2,7 / 15	3,7 / 20,2	3,7 / 20,2	3,8 / 20,2	4,1 / 25	8/25	8/25	5,4 / 26,5
Water exchanger flow rate with high pressure hydraulic module (l/s)	Single min <sup>(3)</sup> / max	2,5 / 11,7	2,5 / 11,7	2,5 / 11,7	2,5 / 11,7	5,2 / 16,1	6,4 / 16,1	3,6 / 26,5	3,7 / 26,5	4,1 / 26,5	4,4 / 26,7	4,8 / 26,7	5,4 / 26,7
	Dual min <sup>(3)</sup> / max	2,6 / 11,7	2,6 / 11,7	2,6 / 11,7	2,6 / 11,7	2,9 / 15,5	3,5 / 15,5	3,4 / 26,5	3,7 / 26,5	4,1 / 26,5	4,4 / 29,2	4,8 / 29,2	5,4 / 35

(1) Minimum flow rate for maximum permitted water temperature difference conditions (10° C)

(2) Maximum flow rate for a pressure drop of 100 kPa in the plate heat exchanger

(3) Minimum factory flow rate setting according to the type of pump

**NOTE:** For the Buffer Tank Module option, the volume of the tank must be taken into account (550 litres)

### OPERATING RANGE

The AQUACIAT<sup>POWER</sup> units have a broad field of application, enabling them to meet a range of requirements in the most varied of climates.

#### Multi-climate: -20°C to +48°C

The AQUACIAT<sup>POWER</sup> HE series is equipped as standard with all the management devices and algorithms to enable all-season operation in all climates. The AQUACIAT<sup>POWER</sup> HE series is therefore able to operate in conditions ranging from the heat of the Mediterranean basin to the chill of Scandinavia, the humid Atlantic coast to the dry climate of Central Europe.

On the ST series, winter operation down to -20°C is optional (standard 0 °C).

#### Multi-application: air conditioning, industrial processes

The AQUACIAT<sup>POWER</sup> can be used for all traditional air conditioning applications in sectors as varied as shared residency, hotels, shopping centres and offices.

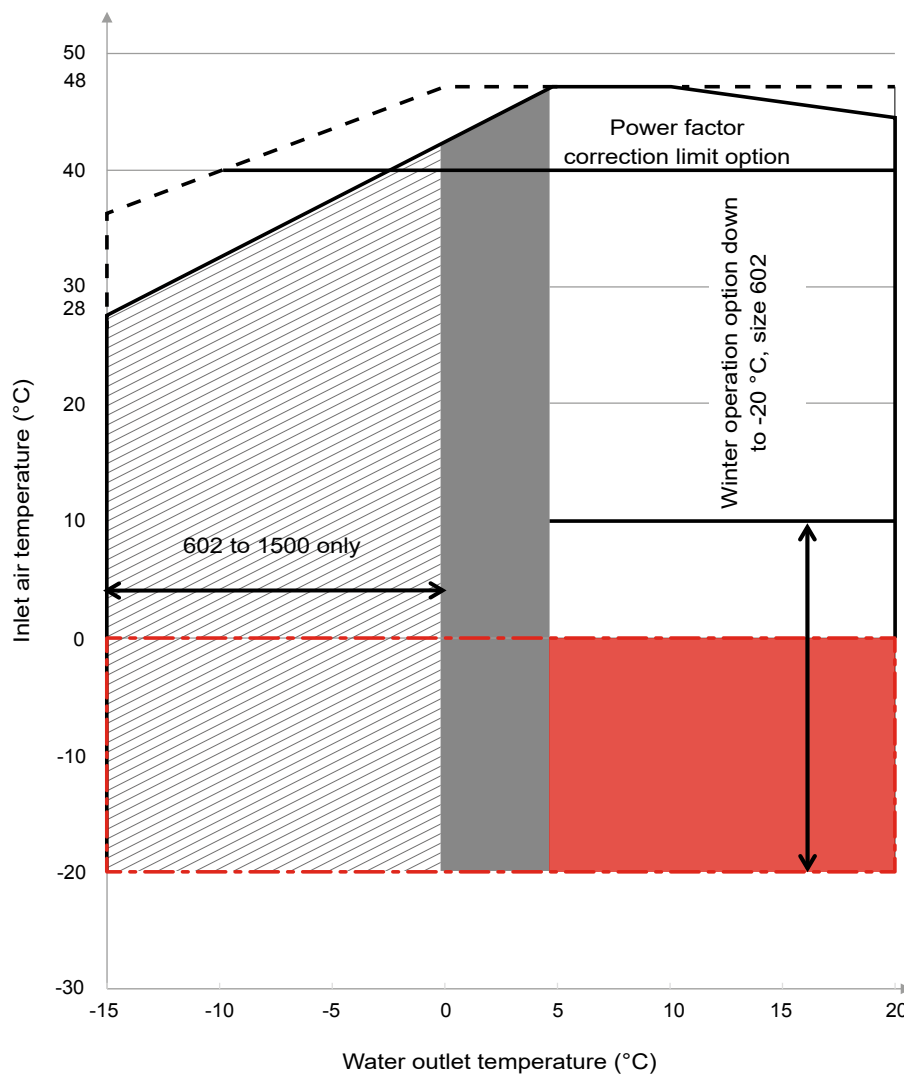

- LD ST/HE full load
- ST version winter operation option (standard HE version)
- Part load
- Medium temperature brine solution option
- Low temperature brine solution option (limit -12 °C with Propylene Glycol and -15 °C with Ethylene Glycol)

Power factor correction option available for an inlet air temperature up to +40°C

For operation in pure water at an inlet air temperature below 0°C, the frost protection option must be provided

## HYDRAULIC SPECIFICATIONS

### ■ Water pressure drop in the evaporator

Data applicable for pure water at 20°C

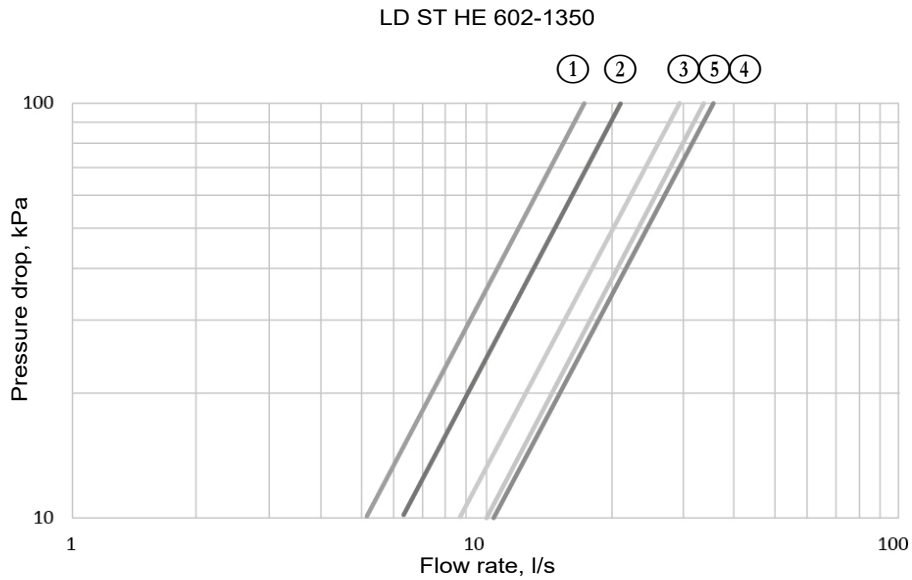

- ① LD 602-800
- ② LD 1000
- ③ LD 1100
- ④ LD 1250
- ⑤ LD 1350

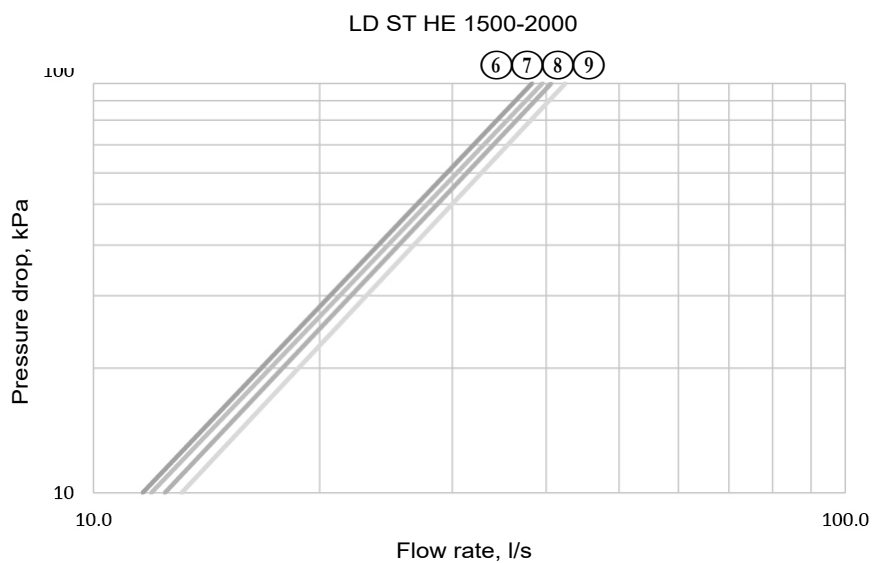

- ⑥ LD 1500
- ⑦ LD 1600
- ⑧ LD 1750
- ⑨ LD 2000

## HYDRAULIC SPECIFICATIONS

### ■ Water pressure drop in the filter

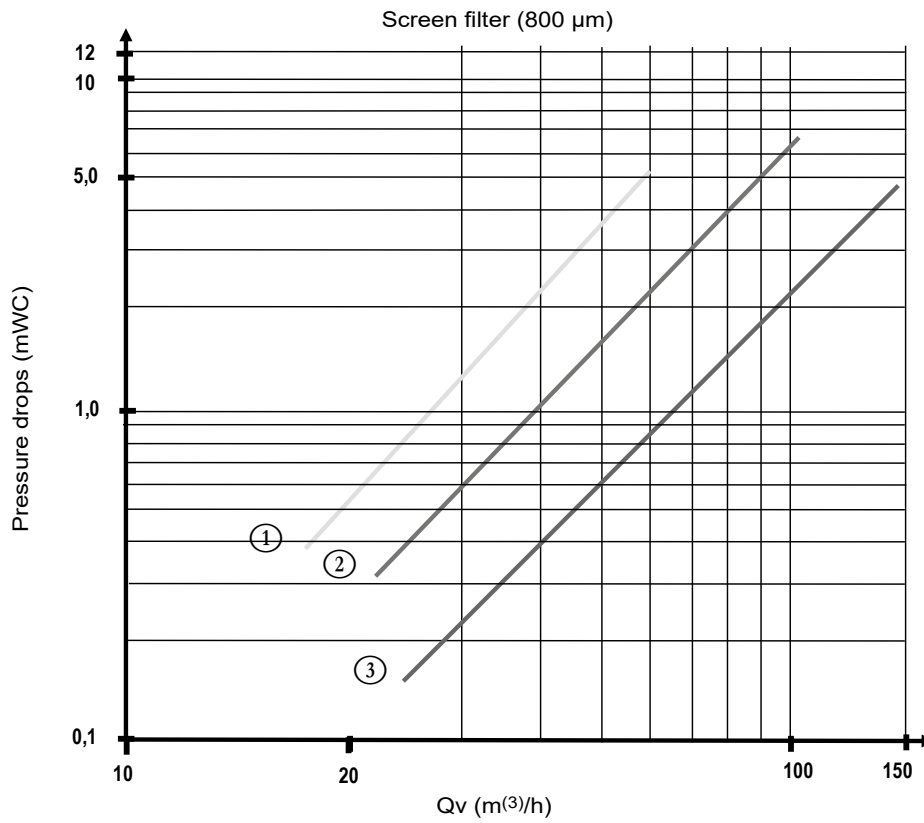

- ① LD 602 - 650
- ② LD 750 - 1100
- ③ LD 1250 - 2000

## HYDRAULIC SPECIFICATIONS

### ■ Available static system pressure

Data applicable for:

- Pure water at 20°C
- Refer to the section "Evaporator water flow rate" for the minimum and maximum water flow rate values
- If a glycol/water mix is used, the maximum water flow rate is reduced

### ■ LD ST / HE high pressure pumps (fixed or variable speed at 50 Hz)

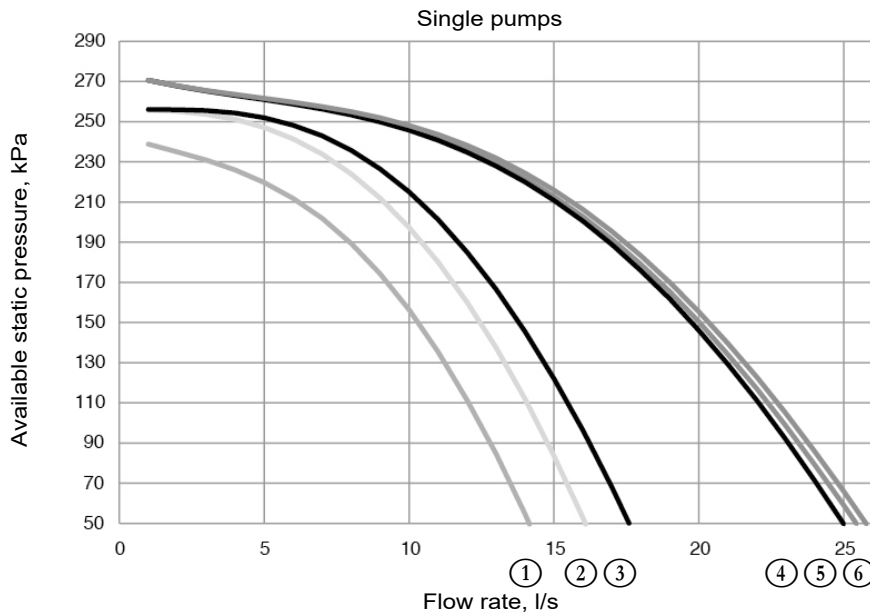

- ① LD 602 - 800
- ② LD 1000
- ③ LD 1100

- ④ LD 1350
- ⑤ LD 1250
- ⑥ LD 1500

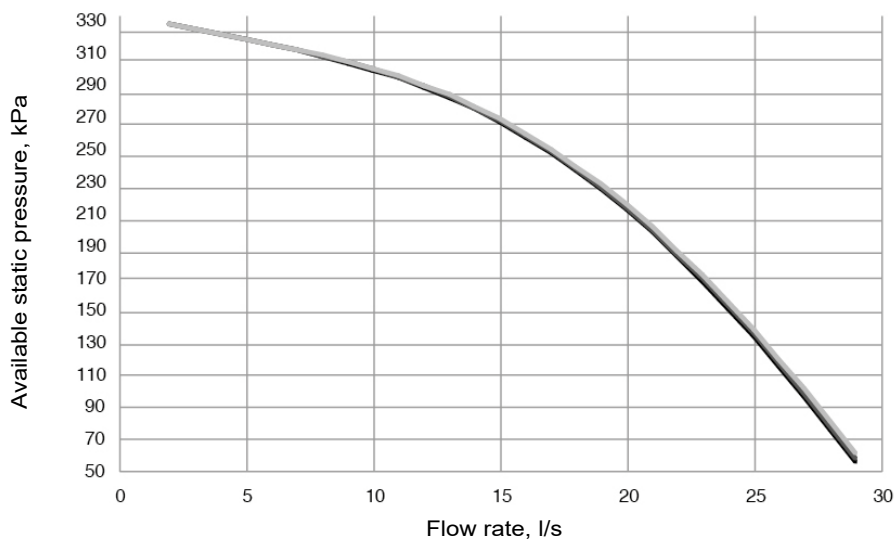

- ⑦ LD 1600
- ⑧ LD 1750
- ⑨ LD 2000



■ LD ST / HE high pressure pumps (fixed or variable speed at 50 Hz)

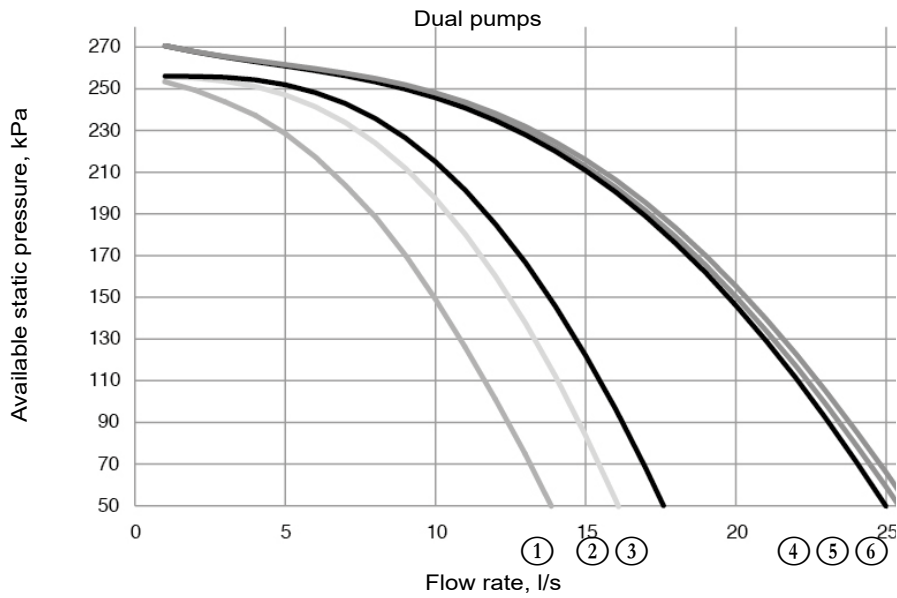

- ① LD 602 - 800
- ② LD 1000
- ③ LD 1100

- ④ LD 1350
- ⑤ LD 1250
- ⑥ LD 1500

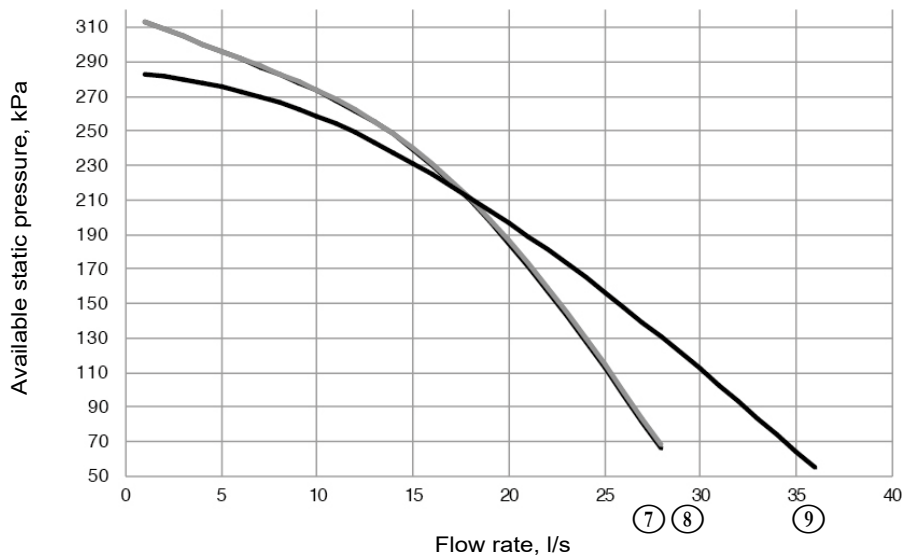

- ⑦ LD 1600
- ⑧ LD 1750
- ⑨ LD 2000

## HYDRAULIC SPECIFICATIONS

### ■ Available static system pressure

Data applicable for:

- Pure water at 20°C
- Refer to the section "Evaporator water flow rate" for the minimum and maximum water flow rate values
- If a glycol/water mix is used, the maximum water flow rate is reduced

### ■ LD ST/HE low pressure pumps (fixed speed)

Single pumps

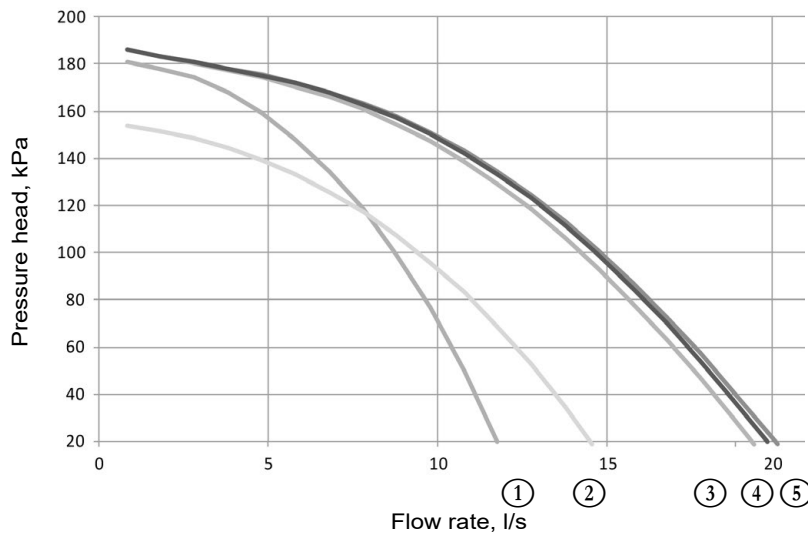

- ① LD 602 - 800
- ② LD 1000
- ③ LD 1100

- ④ LD 1350
- ⑤ LD 1250

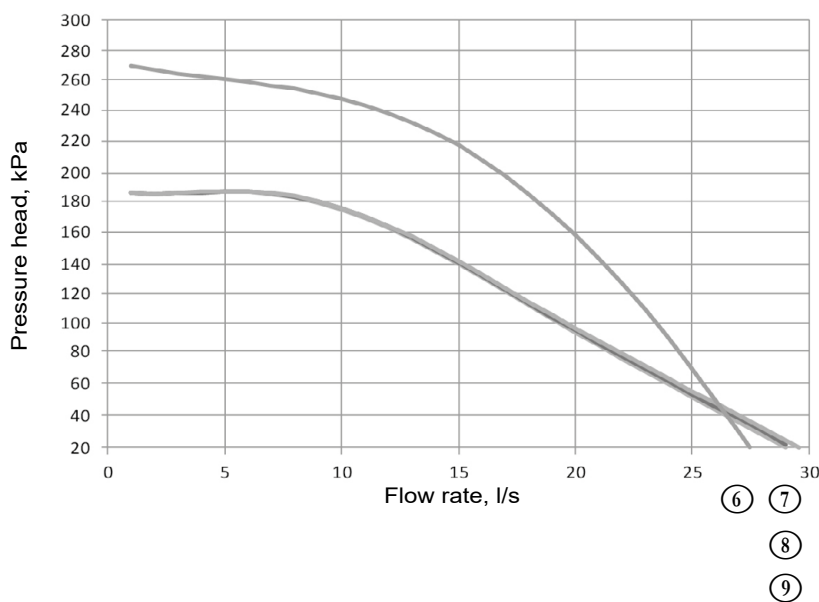

- ⑥ LD 2000
- ⑦ LD 1500

- ⑧ LD 1600
- ⑨ LD 1750

■ LD ST/HE low pressure pumps (fixed speed)

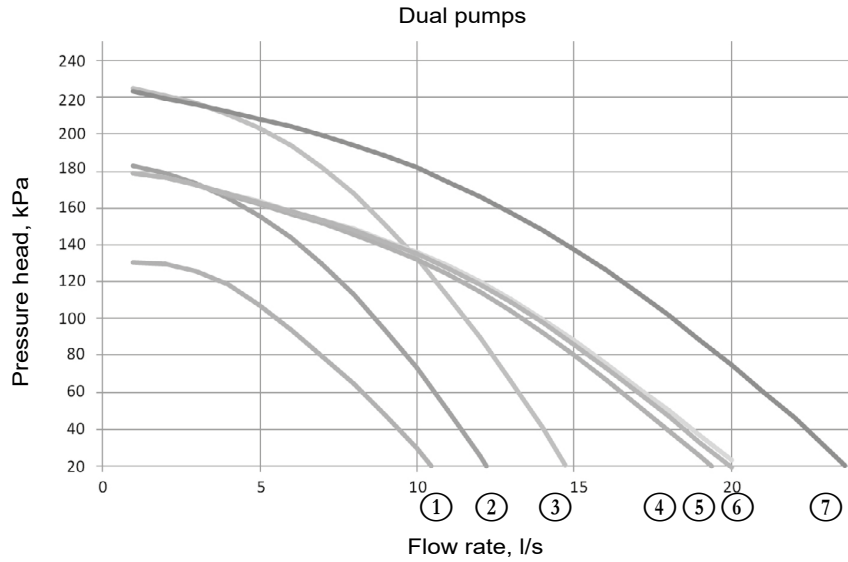

- ① LD 602 - 650
- ② LD 750 - 800
- ③ LD 1000
- ④ LD 1100

- ⑤ LD 1250
- ⑥ LD 1350
- ⑦ LD 1500

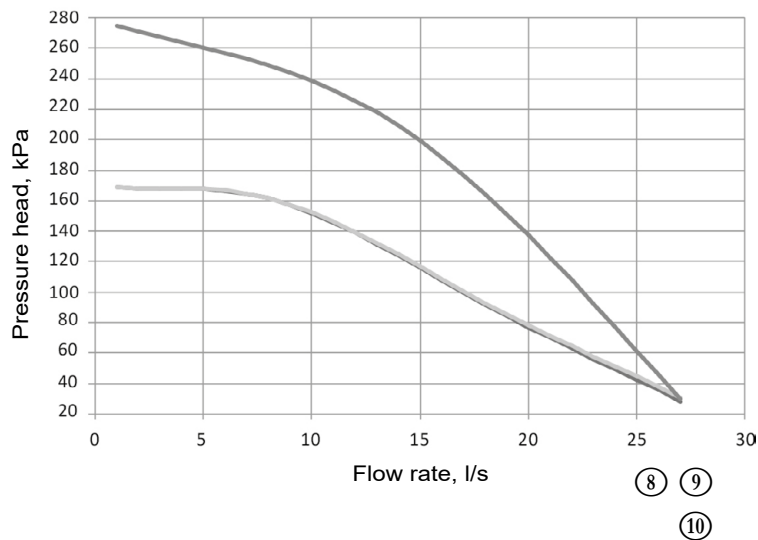

- ⑧ LD 2000
- ⑨ LD 1600
- ⑩ LD 1750

## DIMENSIONS

### ■ AQUACIATPOWER LD ST-HE 602 to 1000 Without buffer tank

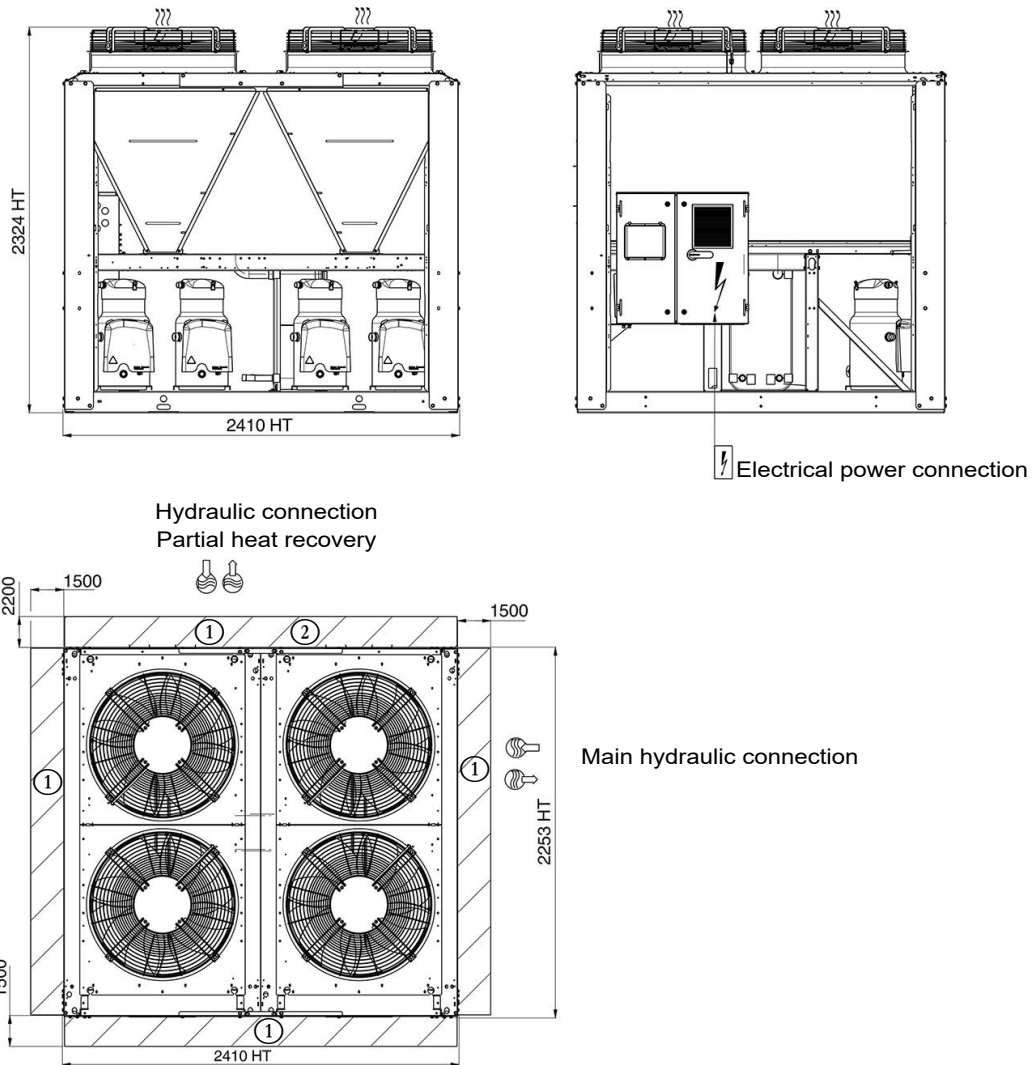

#### Key

All dimensions in mm

① Clearance required for maintenance and air flow

② Clearance recommended for removal of the coils

Water inlet

Water outlet

Air outlet, do not obstruct

Electrical cabinet

#### Notes:

**Non-contractual drawings.**

**When designing a system, refer to the certified dimensional drawings provided with the unit or available on request.**

**Please refer to the certified dimensional drawings for the positioning of the fixing points, weight distribution points and centre of gravity coordinates.**

## DIMENSIONS

### ■ AQUACIATPOWER LD ST-HE 602 to 1000 With buffer tank

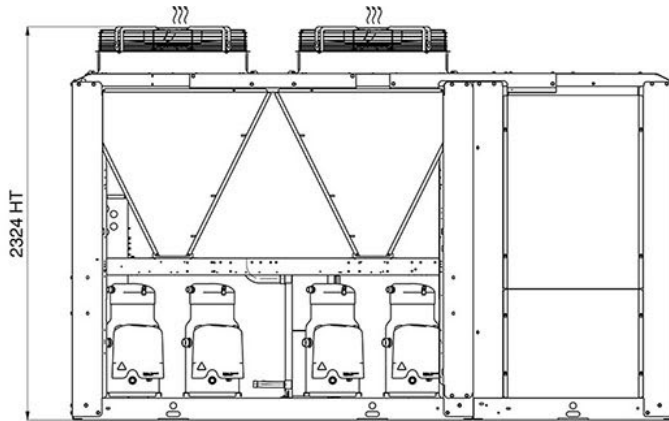

Main hydraulic connection

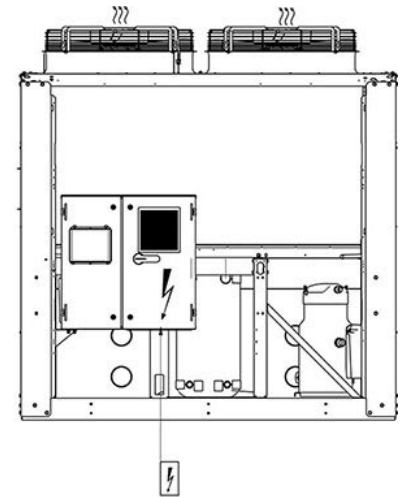

Electrical power connection

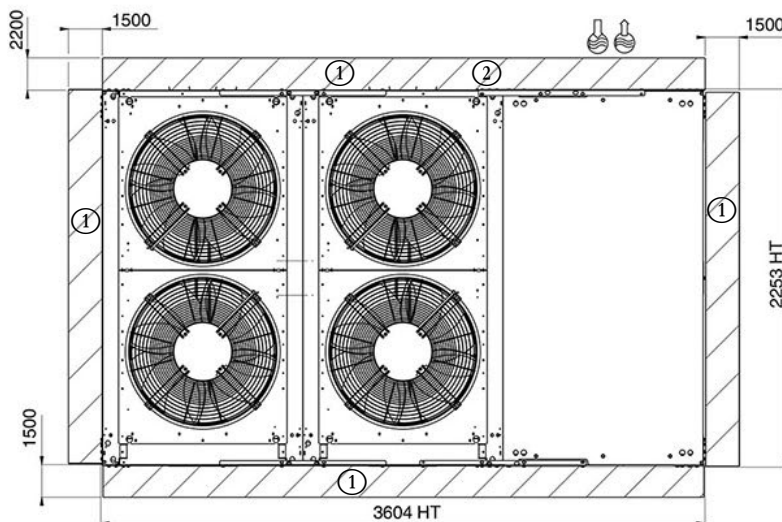

#### Key All dimensions in mm

① Clearance required for maintenance and air flow

② Clearance recommended for removal of the coils

Water inlet

Water outlet

Air outlet, do not obstruct

Electrical cabinet

**Notes:**  
Non-contractual drawings.

When designing a system, refer to the certified dimensional drawings provided with the unit or available on request.

Please refer to the certified dimensional drawings for the positioning of the fixing points, weight distribution points and centre of gravity coordinates.

## DIMENSIONS

### ■ AQUACIATPOWER LD ST-HE 1100 to 1500 Without buffer tank

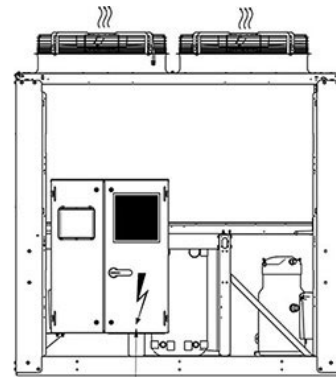
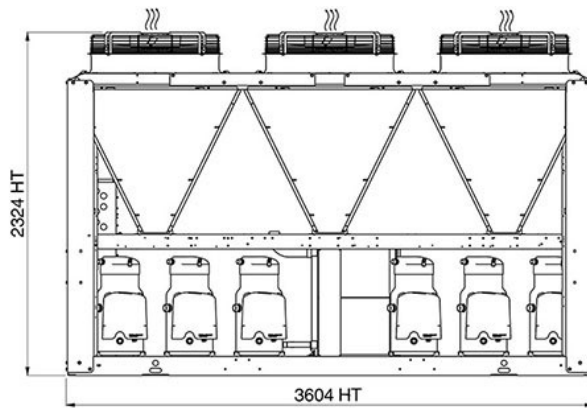

Electrical power connection

Hydraulic connection  
Partial heat recovery

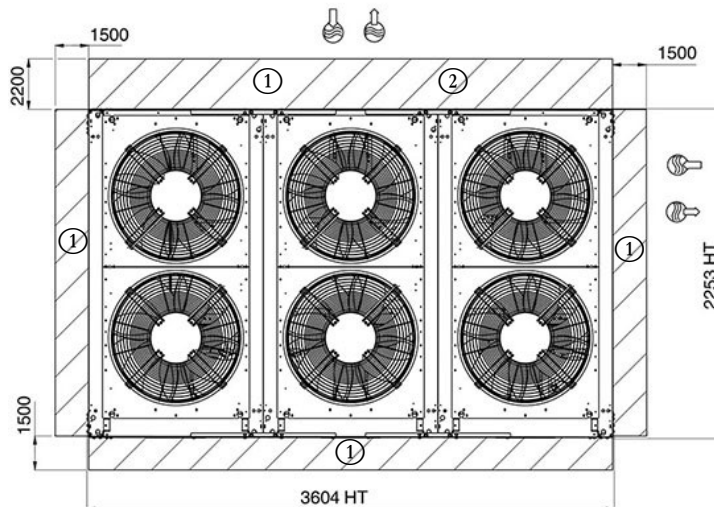

Main hydraulic connection

#### Key All dimensions in mm

① Clearance required for maintenance and air flow

② Clearance recommended for removal of the coils

Water inlet

Water outlet

Air outlet, do not obstruct

Electrical cabinet

**Notes:**  
Non-contractual drawings.

**When designing a system, refer to the certified dimensional drawings provided with the unit or available on request.**

**Please refer to the certified dimensional drawings for the positioning of the fixing points, weight distribution points and centre of gravity coordinates.**

## DIMENSIONS

### ■ AQUACIATPOWER LD ST-HE 1100 to 1500 With buffer tank

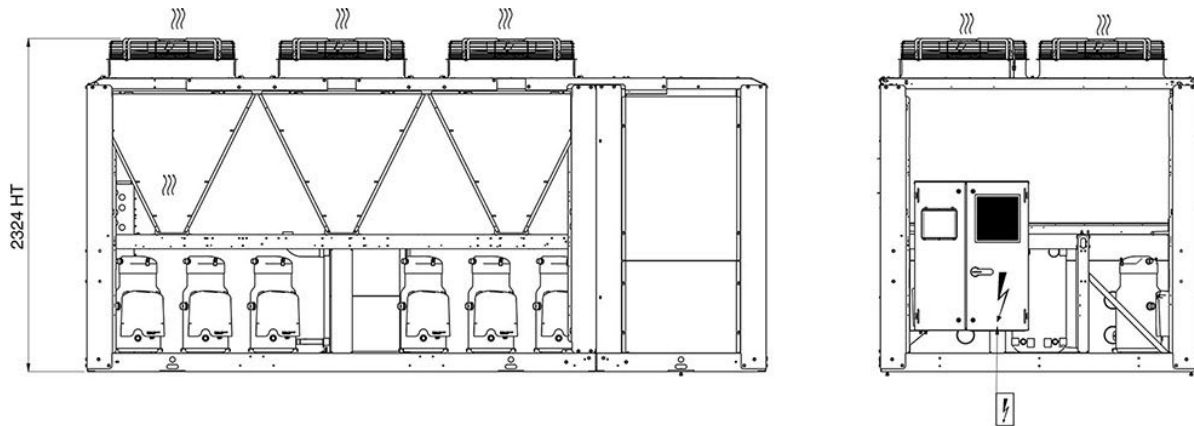

Electrical power connection

Main hydraulic connection

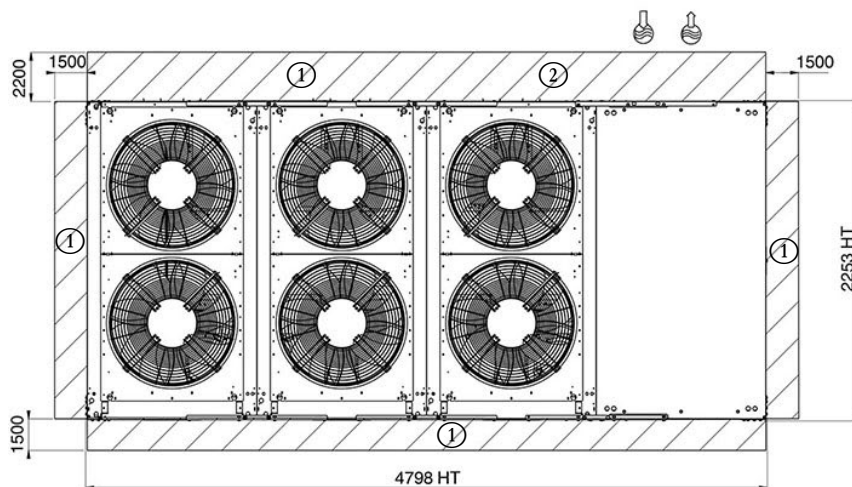

#### Key All dimensions in mm

① Clearance required for maintenance and air flow

② Clearance recommended for removal of the coils

Water inlet

Water outlet

Air outlet, do not obstruct

Electrical cabinet

**Notes:**  
Non-contractual drawings.

When designing a system, refer to the certified dimensional drawings provided with the unit or available on request.

Please refer to the certified dimensional drawings for the positioning of the fixing points, weight distribution points and centre of gravity coordinates.

## DIMENSIONS

### ■ AQUACIATPOWER LD HE 1600 to 2000 Without buffer tank

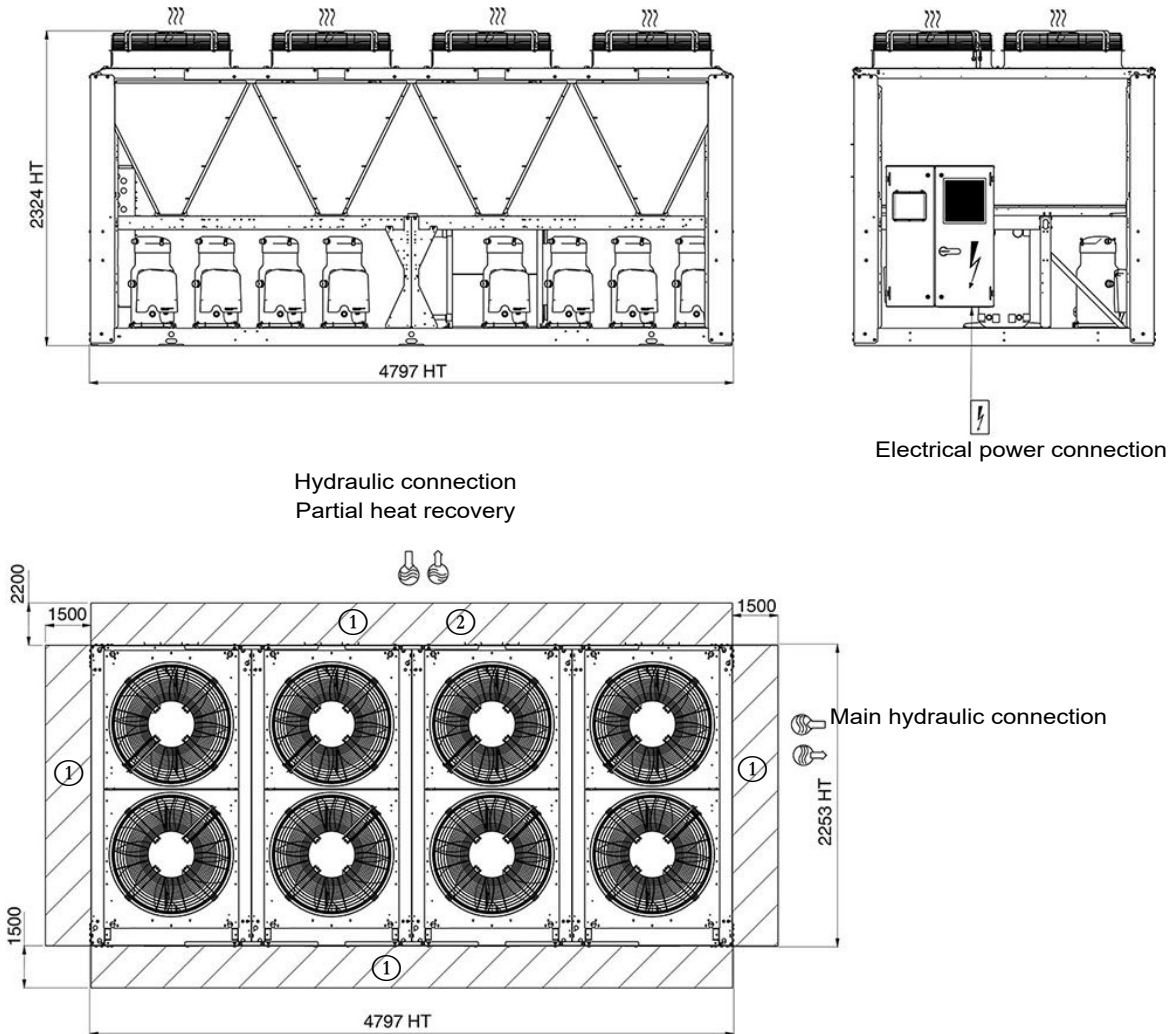

#### Key

All dimensions in mm

① Clearance required for maintenance and air flow

② Clearance recommended for removal of the coils

Water inlet

Water outlet

Air outlet, do not obstruct

Electrical cabinet

#### Notes:

**Non-contractual drawings.**

**When designing a system, refer to the certified dimensional drawings provided with the unit or available on request.**

**Please refer to the certified dimensional drawings for the positioning of the fixing points, weight distribution points and centre of gravity coordinates.**



## DIMENSIONS

### ■ AQUACIATPOWER LD HE 1600 to 2000 With buffer tank

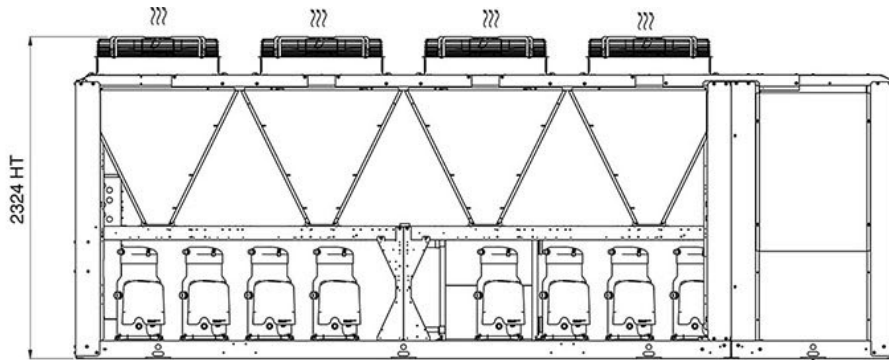

Main hydraulic connection

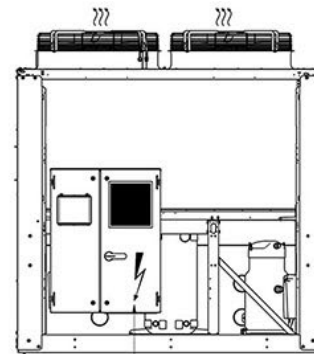

Electrical power connection

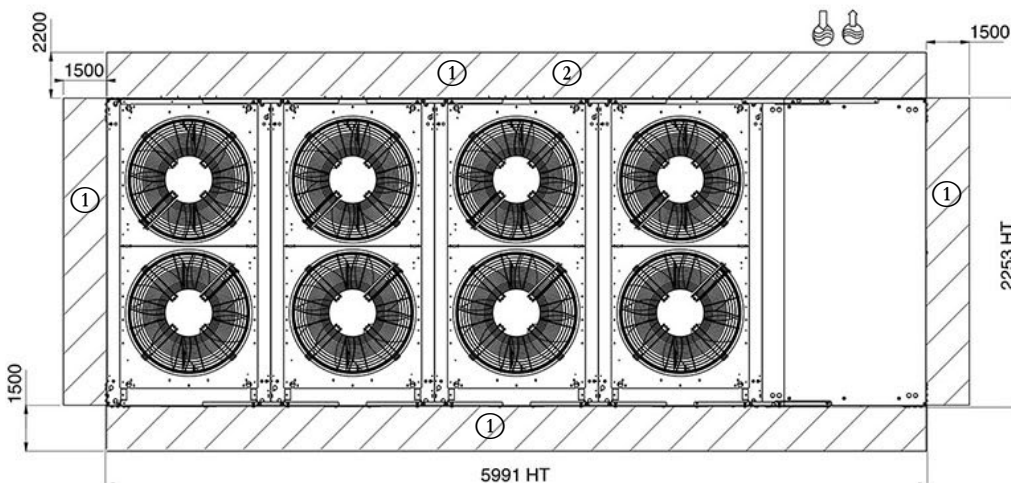

#### Key

All dimensions in mm

① Clearance required for maintenance and air flow

② Clearance recommended for removal of the coils

Water inlet

Water outlet

Air outlet, do not obstruct

Electrical cabinet

#### Notes:

**Non-contractual drawings.**

**When designing a system, refer to the certified dimensional drawings provided with the unit or available on request.**

**Please refer to the certified dimensional drawings for the positioning of the fixing points, weight distribution points and centre of gravity coordinates.**

## INSTALLATION RECOMMENDATIONS

### ■ Water quality criteria to be respected

Warning: it is essential that an 800-micron water filter be placed on the water inlet during installation for units equipped with a brazed-plate heat exchanger. The quality of the water used has a direct impact on the correct and compliant operation of the machine and its service life. This is particularly true if the water used clogs or corrodes components or promotes the growth of algae or micro-organisms. The water must be tested to determine whether it is suitable for the unit. It is also tested to determine whether chemical treatment is necessary and will suffice to make it of acceptable quality. This analysis should confirm whether or not the various machine components are compatible with the water they come into contact with on-site.

**Warning:** failure to follow these instructions will result in the immediate voiding of the unit's warranty.

### ■ Lifting and handling

The utmost safety precautions must be taken when lifting and handling the unit.

Always follow the lifting diagram on the unit and in the instruction manual.

Before attempting to lift the unit, make sure the path leading to its intended location is free from obstacles. Always keep the unit vertical when moving it. Never tip it or lie it on its side.

### ■ Choosing a location for the unit

AQUACIAT<sup>POWER</sup> units are designed for outdoor installation. Precautions should be taken to protect it from freezing temperatures. Special attention should be paid to ensure sufficient free space (including at the top) to allow maintenance. The unit must be placed on a perfectly level, fireproof surface strong enough to support it when ready for operation. Noise pollution from auxiliary equipment such as pumps should be studied thoroughly.

Potential noise transmission routes should be studied, with assistance from an acoustical engineer if necessary, before installing the unit. It is strongly recommended that flexible couplings are placed over pipes and anti-vibration mounts are fitted underneath the unit (equipment available as an option) to reduce vibrations, and the noise this causes, as much as possible.

### ■ Fitting accessories supplied separately

A number of optional accessories may be delivered separately and installed on the unit on site.

You must follow the instructions in the manual.

### ■ Electrical connections

You must follow the instructions in the manual. All information concerning electrical connections is stated on the wiring diagrams provided with the unit. Always follow this information to the letter.

Electrical connections must be made in accordance with best current practices and applicable standards and regulations.

Electrical cable connections to be made on-site:

- Electrical power supply to unit
- Contacts available as standard enabling the machine to be controlled remotely (optional)

It should be noted that the unit's electrical system is not protected against lightning strikes.

Therefore devices to protect against transient voltage surges must be installed on the system and inside the power supply unit.

### ■ Pipe connections

You must follow the instructions in the manual. All pipes must be correctly aligned and slope toward the system's drain valve. Pipes must be installed and connected to allow sufficient access to the panels and fitted with heat insulation.

Pipe fixings and brackets must be separate to avoid vibrations and ensure no pressure is placed on the unit. Water flow shut-off and control valves must be fitted when the unit is installed.

Pipe connections to be made on site:

- water supply with pressure-reducing valve
  - evaporator, condenser and drain
- Accessories essential to any hydraulic circuit must also be installed, such as:
- water expansion vessel
  - drain nozzles at pipe low points
  - exchanger shut-off valves equipped with filters
  - air vents at pipe high points
  - check the system's water capacity (install a buffer water tank if necessary)
  - flexible couplings on exchanger inlets and outlets.

### Warning:

- Pressure in the water circuits below 4 bar for units equipped with the hydraulic module
- Place the expansion vessel upstream of the pump
- Do not place any valves on the expansion vessel
- Make sure the water circulation pumps are placed directly at the exchanger inlets
- Make sure the pressure of the water drawn in by the circulation pumps is greater than or equal to the required minimum pressure (NPSH), particularly if the water circuits are "open"
- Test the water quality in accordance with the relevant technical specifications
- Take the necessary precautions to protect the unit and hydraulic system from freezing temperatures (e.g. allow for the possibility of draining the unit). If glycol is added to prevent freezing, check its type and concentration before system start-up
- Before making any final hydraulic connections, flush the pipes with clean water to remove any debris in the network.

**■ System start-up**

System start-up for these machines must be performed by CIAT or a CIAT-authorized firm.

You must follow the instructions in the manual.

List of system start-up checks (non-exhaustive):

- Correct positioning of unit
- Power supply protections
- Phases and direction of rotation
- Wiring connections on unit
- Direction of water flow in unit
- Cleanliness of water circuit
- Water flow rate at specified value
- Pressure in the refrigerating circuit
- Direction of rotation of compressors
- Water pressure drops and flow rates
- Operating readings

**■ Maintenance operations**

Specific preventive maintenance operations are required at regular intervals and should be performed by CIAT-approved contractors.

The operating parameters are read and noted on a "CHECK LIST" form to be returned to CIAT.

To do this, you must refer to and comply with the instruction manual.

You must take out a maintenance contract with a CIAT-approved refrigeration equipment specialist. Such a contract is required even during the warranty period.

## CONNECT TOUCH CONTROL

### USER-FRIENDLY INTERFACE CONSOLE

- User-friendly 4.3 inch touch screen.
- Information displayed in a choice of languages.
- Temperature and pressure readings.
- Operating and fault status diagnostics.
- Master/slave control of two machines in parallel.
- Fault memory management.
- Pump management.
- Time schedule.
- IP Web server.
- Programmable maintenance.
- Preventive maintenance.
- FGAS maintenance.
- E-mail alerts.



### REMOTE M2M MACHINE SUPERVISION

#### Two years of Full Serenity with:

- Monitoring of machine operation (operation overviews and curves, alarm logs).
- E-mail alerts for alarms (optional SMS alerts).
- Remote update of the M2M.
- Access to a log of machine operation data.
- Remote advice for using M2M.
- System start-up and operating readings.

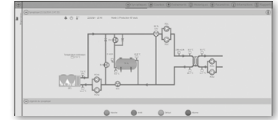

## PRODUCT FUNCTIONALITY

### POTENTIAL-FREE (DRY) CONTACTS AVAILABLE AS STANDARD

- Inputs:**
- Automatic operation control
  - Selection of setpoints 1 / 2
  - Power limitation

- Outputs:**
- General fault reporting
  - Operational status reporting

#### Additional inputs available as options:

- Setpoint adjustable by 4-20 mA signal
- Power limitation adjustable by 4-20 mA signal
- Second power limitation level
- End of storage signal
- User fault reporting
- Time schedule override
- Contact for refrigerant leak detector

#### Additional outputs available as options:

- Indication of the power level by 0-10 V signal
- Minor alert reporting
- Unit shut down general fault reporting
- Desuperheater pump On/Off control

Via dry contact

Customer CMS  
COMMUNICATION

Via BUS  
communication

### CMS CONNECTIONS

- MODBUS-JBUS RTU (RS485) or TC/IP (standard) open protocol
- LONWORKS protocol (option)
- BACNET IP protocol (option)

## CIAT SYSTEM FUNCTIONALITY

Communication with CIAT Energy pool controlled by PowerCTRL.

#### Integrated PowerCTRL:

- Energy optimisation of refrigeration and heating using several generators,
- Manages free cooling capacity
- Uses heat recovery to supply domestic hot water.





# AQUACIATPOWER LD

Water chillers



Order No.: NA21.747A. Supersedes order No.: NA20.747B.  
Manufacturer reserves the right to change any product specifications without notice.

Manufactured by: Carrier SCS, Montluel, France.

The illustrations in this document are for illustrative purposes only and not part of any offer for sale or contract. The manufacturer reserves the right to change the design at any time without notice.