



AQUACIAT^{POWER}™ LD/ILD

Water chiller
& heat pump

*The high-performance
packaged solution, now
available for R-32*

Compact and silent

Scroll compressors

High-efficiency brazed-plate heat exchangers

Self-adjusting electronic control

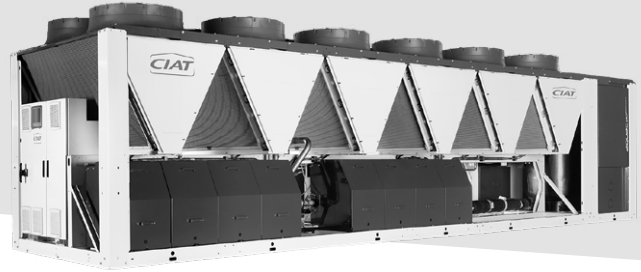

Cooling capacity: 170 to 940 kW
Heating capacity: 160 to 1040 kW



Cooling and
heating



Hydraulic
module



Heat
recovery



Free Cooling



R-32



USE

The new generation of **AQUACIAT^{POWER}** high-efficiency air-to-water heat pumps and water chillers offers an optimal solution for all heating and cooling applications used for the Healthcare, Office, and Hotel sectors.

These units are designed for outdoor installation and require no special protection against adverse weather conditions.

AQUACIAT^{POWER} is optimised for R-32, the environmentally-responsible fluid with the lowest GWP.

This range guarantees compliance with the most demanding requirements for increased seasonal energy efficiency (SEER and SCOP) and CO₂ reduction to comply with the various applicable European directives and regulations.

■ Self-regulating operation to adapt to seasonal variations and requirements

With exceptional SEER and SCOP seasonal energy efficiency levels, the **AQUACIAT^{POWER}** range offers the best technology combined with savings throughout the year.

Due to climatic variations and the different air-conditioning needs of tertiary buildings, most of the time water chillers and heat pumps run at part load.

Equipped with multiple compressors, **AQUACIAT^{POWER}** units automatically adjust the cooling capacity by anticipating changes in load and only starting the number of compressors required to guarantee optimal operation and energy efficiency.

The optional variable-speed fan motors guarantee even better results.

Thanks to their exceptional thermodynamic performance, provided by a radical selection of components, an electronic expansion valve as standard and a specific control function, standard **AQUACIAT^{POWER}** units reach a high level of seasonal efficiency in cooling mode (SEER) and in heating mode (SCOP).

■ Acoustic comfort

With different levels of sound equipment available, the **AQUACIAT^{POWER}** range guarantees the acoustic comfort of occupants and meets the needs of the most sensitive environments, including hotels, offices and hospitals.

■ Quick, simple installation

With a wide variety of connection accessories and equipment, the **AQUACIAT^{POWER}** range is quick and simple to install.

The advanced controller functions and different communication protocols enable local control via CMS/BMS or remote control, providing building management with peace of mind.



OFFICES



HOTELS



HEALTHCARE



INDUSTRY



GLOBAL SYSTEM SOLUTIONS

As an expert on customised HVAC solutions, CIAT works to improve the well-being of individuals in their living areas or places of work. Aware of the thermal, energy and air quality issues faced today by every sector of activity, CIAT has responded by developing global systems based on an adapted and efficient combination of products. The latest-generation **AQUACIAT^{POWER}** with a low environmental footprint is part of our sustainable development process.

■ Global energy systems based on the water loop for heating, cooling and indoor air quality

To comply with today's thermal and environmental regulations, CIAT designs optimised energy systems based on the water loop comprised of comfort units, heat pumps such as **AQUACIAT^{POWER}** and dual-flow air handling units. As a renewable resource and a highly effective energy transfer fluid, water not only represents an excellent alternative to direct expansion systems, it also meets F-Gas regulations in terms of confinement and limitation of refrigerants within buildings.

■ Benefits of the water loop

- **More competitive:** equipment that is more cost effective and requires less maintenance than direct expansion systems.
- **Greater comfort:** flexible, precise control of occupant comfort.
- **Greater energy efficiency:** the homogeneity and the thermal stability of water reduce the energy requirements for transferring heat.
- **Environmentally sustainable:** no refrigerant is required on the premises and only a small amount is used in the heat pump installed outside the building's occupied spaces.
- **Easy to install:** no refrigerant specialists are required during installation.
- **Flexibility:** an energy system based on the water loop adapts easily to the configuration of buildings and the changes that may be made to spaces over time.

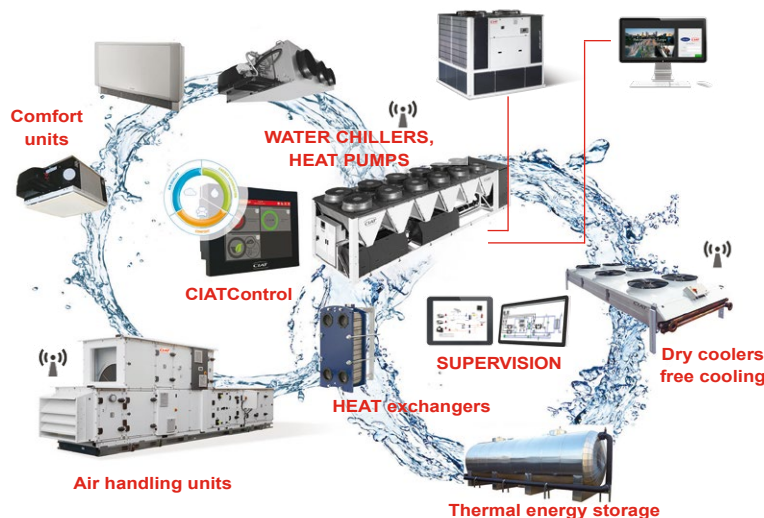

RANGE

■ AQUACIAT^{POWER} LD/ILD series

In the LD water chiller & ILD standard reversible heat pump versions, **AQUACIAT^{POWER}** units are optimised to meet the most demanding technical and economic requirements.

■ Units with nominal high energy performance (option)

In this configuration, the **AQUACIAT^{POWER}** unit is optimised for full-load applications for which an optimum EER and COP value are required. In this case, the machine is equipped with high-speed fans enabling nominal efficiency and a broader application range.

■ Units equipped with variable-speed fans (option)

High seasonal energy efficiency version.

In this configuration, the **AQUACIAT^{POWER}** unit is optimised for part load applications for which an optimum SEER and SCOP value are required. In this case, the machine is equipped with variable-speed fans, optimising the part load efficiency throughout the year.

DESCRIPTION

AQUACIAT^{POWER} units are packaged machines supplied as standard with the following components:

- Hermetic SCROLL compressors
- Brazed plate condenser or evaporator water type heat exchanger
- All-aluminium micro-channel condenser (LD) or evaporator air-cooled exchanger, copper tube coil with aluminium fins (ILD) and axial fan motor assembly
- Electrical power and remote control cabinet:
 - 400 V-3ph-50 Hz (+/-10%) mains power supply + Earth
 - Transformer fitted as standard on the machine for supplying the remote control circuit with 24 V
- Connect Touch electronic control module
- Casing for outdoor installation

The entire **AQUACIAT^{POWER}** range complies with the following EC directives and standards:

- Machinery directive 2006/42/EC.
 - Electromagnetic compatibility directive 2014/30/EC
 - Safety of machinery: Electrical equipment of machines EN 60204-1
 - EMC immunity and emissions EN 61800-3 'C3'
 - Regulation (EC) No. 1907/2006 REACH
- Pressure equipment directive (PED) 2014/68/EU
- Refrigerating systems and heat pumps EN 378-2
 - Regulation (EU) No. 813/2013 implementing Directive 2009/125/EC with regard to ecodesign requirements (Heat pump)
 - Regulation (EU) No. 2016/2281 implementing Directive 2009/125/EC with regard to ecodesign requirements (Chiller)

CONFIGURATION

	Energy versions	
Acoustic versions	High outdoor temperature option	Rated high performance option
	AQUACIAT^{POWER} Standard (AC motor fans)	AQUACIAT^{POWER} Seasonal high-performance version (Optional AC motor fans + Inverter or EC motor fans)
	Very Low Noise option	Very Low Noise option
	Ultra Low Noise option	Ultra Low Noise option

Digit number

1	2	3	4	5	6	7	8	9	10	11	12	13	14	15	16	17	18
L	D	-	-	0	6	0	2	R	-	A	0	0	0	1	-	-	-

Product code

Legend

- Digit 1 to 4 : Model series, LD-- = for air cooled cooling only, ILD-- = for air to water heat pump
- Digit 5 to 8 : Model size number
- Digit 9 : R = R32 refrigerant
- Digit 10 : Not used
- Digit 11 : Major revision index
- Digit 12 to 15 : Counter used to generate a one time product code
- Digit 16 : Not used

CUSTOMER BENEFITS

Environmental responsibility

We are committed to meeting your strictest environmental requirements.

We focus our energies on making our products ever more efficient and environmentally friendly.

AQUACIAT^{POWER} R-32 exceeds the requirements of Ecodesign 2021.



R-32



Simplicity

To save you time, we guarantee easy installation and integration in the building management system.

- No machine room required for the pumps and other accessories thanks to the hydraulic module option.
- Optimum use of the surface area for easy integration into an existing building.
- Quick, easy installation and system start-up.
- Packaged solution for quick start-up and reliable installation.
- Communication with all types of building management system (BMS) via Modbus protocol available as standard, or optional LON or BACNET protocols.



User comfort

We guarantee acoustic comfort for your users.

Thanks to fans with low noise levels installed as standard and the noise reduction technologies integrated into the new **AQUACIAT^{POWER}** range, we can guarantee a level of acoustic comfort which meets the expectations of your users, even in night mode.



ULTRA LOW NOISE LEVEL

-5 to -6 dB(A) reinforced noise insulation on the compressors and all of the components which generate noise

NIGHT MODE

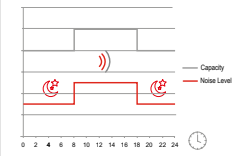

Reliability

We use state-of-the-art monitoring solutions to guarantee complete reliability for your equipment.

ABOUT HVAC Performance lets you track and monitor your CIAT equipment.

- Data extraction in real time via customised access to the ABOUT HVAC Performance website (controller control panel, temperature/event curve, fault memory and alerts and parameter history).
- Email alert.
- Analysis and recommendations from CIAT experts



Energy savings

We develop solutions to enable substantial savings while protecting the environment and guaranteeing user comfort.

Heat recovery options can be used to produce free additional hot water at a high temperature. This hot water can be used to prepare domestic hot water for heating swimming pools, spas and hot tubs.

30% energy

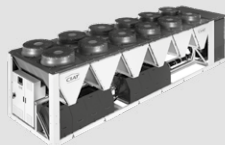

- ❄️/☀️ | 100% Chilled or hot water production
- + 80°🍷 | 25% Domestic hot water production
- or 65°🍷 | 100% Hot water production

The free cooling option is used to provide significant energy savings for all for applications which require cooling all year round or during the night, particularly in cold regions.

In these regions, free cooling is a very effective and environmentally-friendly means of meeting a large proportion of the cooling requirements.

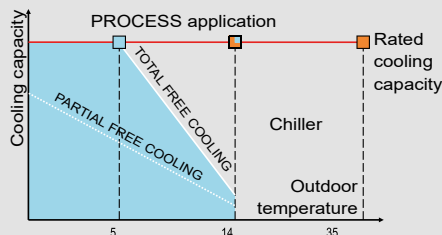

FREE COOLING: The economical cooling solution

MAIN COMPONENTS



Fixed-speed fans (standard) Variable-speed fans (Inverter or EC motor option)

Fan spigot made from composite material

Micro-channel coil, LD cooling only version

Copper-aluminium coil, ILD heat pump version

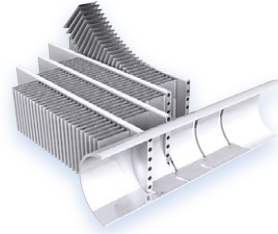

Hydraulic module option with or without buffer tank

Variable or fixed speed pump



Connect Touch control



Optimised scroll compressors

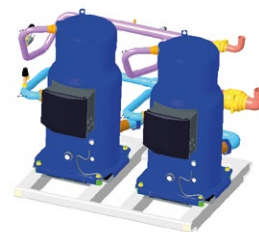

Asymmetrical brazed-plate heat exchanger



R-32

Electronic expansion valve

DESCRIPTION OF THE MAIN COMPONENTS

■ Compressors

- Hermetic SCROLL type
- Electronic motor overheating protection
- Crankcase heater
- Mounted on anti-vibration mounts

■ Water type heat exchanger

- Asymmetrical brazed plate heat exchanger
- Plate patterns optimised for high efficiency
- 19-mm armafex thermal insulation

■ Air-cooled exchanger

- Liquid chiller: air-cooled exchanger, all-aluminium, micro-channels
- Heat pump: air-cooled exchanger, copper tube coil, aluminium fins
- Propeller fans with composite blades offering an optimised profile with fixed speed or variable speed depending on the model, variable-speed option using frequency inverter or EC motor
- Motors – IP 54, class F

■ Refrigerating accessories

- Dehumidifier filters with rechargeable cartridges
- Hygroscopic sight glasses
- Electronic expansion valves
- Service valves on the liquid line
- Four-way reverse cycle valve in cooling/heating mode

■ Control and safety instruments

- Low and high pressure sensors
- Safety relief valves on refrigerant circuit
- Water temperature control sensors
- Evaporator antifreeze protection sensor
- Factory-fitted evaporator water flow controller

■ Electrical cabinet

- Electrical cabinet with IP 54 protection rating
- A connection point without neutral
- Front-mounted main disconnect switch with handle
- Control circuit transformer
- 24 V control circuit
- Compressor and fan motor protection devices
- Fan and compressor motor contactors
- Connect Touch microprocessor-controlled electronic control module
- Wire numbering
- Marking of the main electrical components



■ Casing

Casing made from RAL 7035 light grey & RAL 7024 graphite grey painted panels

■ Connect Touch control module

- User interface with 4.3-inch touch screen
- Intuitive, user-friendly navigation using icons
- Clear text display of information available in 7 languages (FR-EN-DE-ES-I-PT-NL)



The electronic control module performs the following main functions:

- Regulation of the chilled water temperature (at the return or at the outlet)
- Control of the water temperature based on the outdoor temperature (water law)
- Control for low temperature energy storage
- Management of a second setpoint
- Complete management of the compressors with start-up sequence, timer and operation time balancing
- Self-adjusting and proactive functions with adjustment of settings on drift control
- In-series staged power control system on the compressors according to the thermal requirements
- Management of compressor short-cycle protection
- Frost protection (exchanger heater option)
- Compressor phase reversal protection
- Optimised defrosting with free defrost function to optimise part-load performance and the SCOP
- Management of occupied/unoccupied modes (according to the time schedule)
- Compressor and pump operation time balancing
- Management of the machine operation limit according to outdoor temperature
- Sound level reduction device (night mode according to the user programme) with limitation of compressor capacity and fan speed
- Diagnosis of fault and operating statuses
- Management of a fault memory allowing a log of the last 50 incidents to be accessed, with an operating reading taken when the fault occurs
- Blackbox memory
- Master/slave management of the two machines in parallel with operation time balancing and automatic changeover if a fault occurs on one machine
- Weekly and hourly time schedule for the machine, including 16 periods of absence
- Pump standby based on demand (energy saving)
- Calculation of the water flow rate and operating pressure (hydraulic module version)
- Electronic adjustment of the water pump speed and water flow rate (variable-speed pump option)
- Display of all machine parameters (3 access levels, User/Maintenance/Factory, password-protected): temperature, setpoints, pressures, water flow rate (hydraulic version), operation time.

DESCRIPTION OF THE MAIN COMPONENTS

- Display of trend curves for the main values
- Storage of maintenance manual, wiring diagram and spare parts list.
- Innovative smart energy monitoring, providing users with smart data such as real-time electrical energy consumption and heating and cooling capacity, and instantaneous and average energy efficiency rates.

■ Remote management

Connect Touch is equipped as standard with an RS485 port and an ETHERNET (IP) connection, offering a range of options for remote management, monitoring and diagnostics.

Using the integrated Webserver, a simple internet connection uses the unit's IP address to access the Connect Touch interface on the PC, facilitating everyday management tasks and maintenance operations.

A range of communication protocols are available: MODBUS/JBUS RTU (RS485) or TC/IP as standard, LONWORKS – BACNET IP (BTL certified) as an option, enabling most CMS/BMS to be integrated

Several contacts are available as standard, enabling the machine to be controlled remotely by wired link:

- Automatic operation control: when this contact is open, the machine stops
- Heating/cooling mode selection
- Setpoint 1/setpoint 2 selector: when this contact is closed, a second cooling setpoint is activated (energy storage mode, for example)
- Power limitation: closing the contact concerned allows the power or refrigerating consumption of the machine to be limited by stopping one or more compressors (this limit can be set with a parameter)
- Fault reporting: this contact indicates the presence of a major fault which has caused one or both refrigerant circuits to stop
- Operational status reporting indicates that the unit is in production mode.
- Activation control for partial energy heat recovery unit using the desuperheater.
- Switch control for the customer pump, external to the machine (on/off).

Contacts available as an option:

- Setpoint adjustable via 4-20 mA signal: this input is used to adjust the setpoint in COOLING mode
- On/off control for a boiler
- 4-stage on/off management for additional heaters
- Power limitation adjustable by 4-20 mA signal
- Second power limitation level
- Power indication: analogue output (0-10 V) providing an indication of the unit's load rate.
- user fault reporting, enables integration of a fault in the water loop
- General fault reporting: this contact indicates that the unit has stopped completely
- alert reporting: this contact indicates the presence of a minor fault which did not cause the refrigerant circuit in question to stop.

- End of storage signal: enables return to the second setpoint at the end of the storage cycle
- Schedule override: closing this contact cancels the time schedule.
- desuperheater activation control
- Desuperheater pump On/Off control.

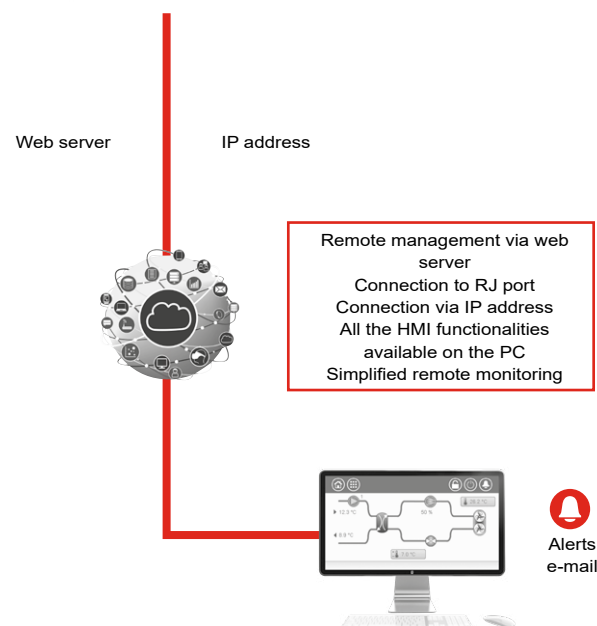

■ Maintenance

Connect Touch has two maintenance reminder functions as standard, making users aware of the need to regularly perform maintenance operations and to guarantee the service life and performance of the unit. These two functions can be activated independently.

A reminder message appears on the unit's HMI screen, and stays there until it is acknowledged by the maintenance operator. The information and alert relating to these functions are available on the communication bus to be used on the CMS/BMS.

- The scheduled maintenance reminder: when activated, this function enables the period between two maintenance inspections to be set. This period may be set by the operator in either days, months or operating hours, depending on the application.
- The compulsory F-GAS sealing test maintenance reminder: when activated, this function, which is the default factory setting, enables the period between two sealing tests to be selected, according to the unit's refrigerant charge, in compliance with the F-GAS regulations.

PEACE OF MIND

ABOUND

Complete reliability thanks to state-of-the-art monitoring solutions: ABOUND HVAC Performance

■ ABOUND HVAC Performance, the CIAT monitoring solution

ABOUND HVAC Performance is a remote supervision solution dedicated to monitoring and controlling several CIAT machines in real time.

Advantages

- Access to the operating trend curves for analysis
- Improved energy performance
- Improved availability rate for the machines

Functions

ABOUND HVAC Performance will send data in real time to a supervision website.

The machine operating data can be accessed from any PC, smartphone or tablet.

Any event can be configured to trigger a mail alert.

Parameters monitored:

- Synoptic
- Control panel for the controllers
- Events
- Temperature curves

Monthly and annual reports are available to analyse:

- The performance and operation of the machine
Example: operating curves and time, number of compressor starts, events, preventive maintenance actions to be performed, etc.

Incidents such as a drift in the measurements on a temperature sensor, incorrectly set control parameters, or even incorrect settings between one compressor stage and the other, are immediately detected, and the corrective actions put in place.

Equipment

This box can be used both on machines which are already in use (existing inventory), and on new machines.

- 1 transportable cabinet

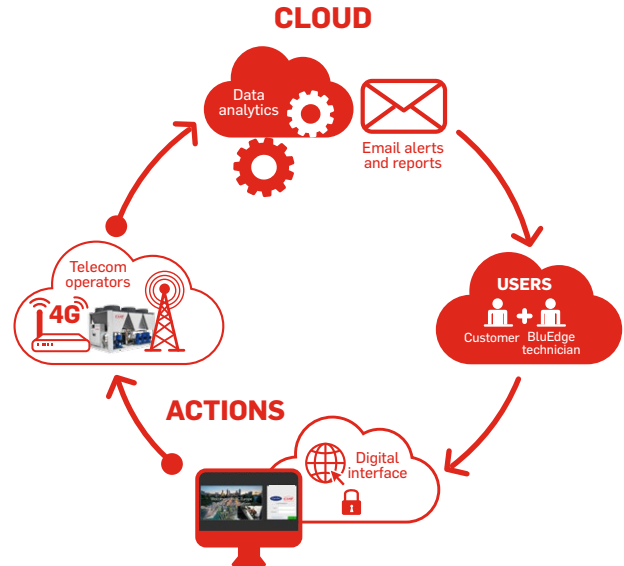

Composition of the box (available in 230 V and 400 V)

- 1 GPRS / 4G LTE-M modem
- 1 SMART SIM card
- 1 power supply (24 VDC)
- 1 power protection device
- 1 GSM antenna
- Rail mounting
- Enclosed casing to protect the equipment during transport
- Packing box for cable routing (bus, power supply)

Compatibility

Up to 5 machines per box

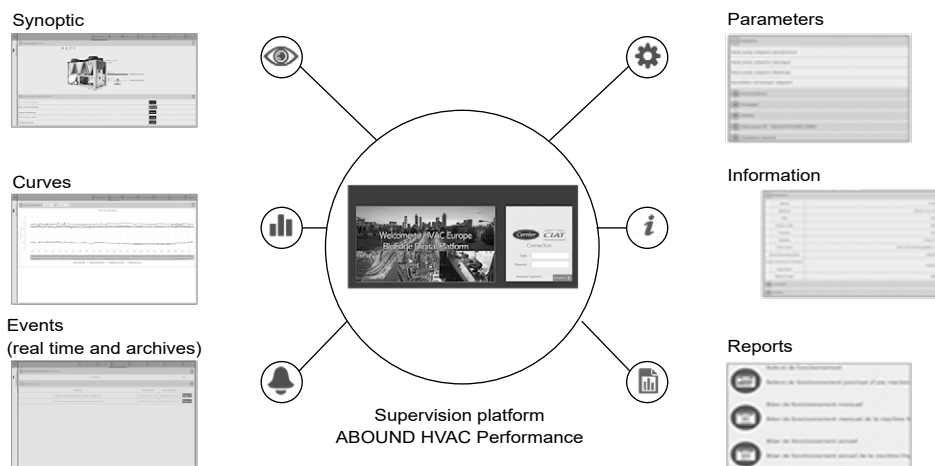

SEASONAL PERFORMANCE IN COOLING MODE



Analyses of installed systems show that the heat load varies from season to season and that a water chiller operates at reduced capacity for the majority of the time.

Part load efficiency is therefore essential when choosing a water chiller. It is with this in mind that the new **AQUACIAT^{POWER}** range was designed. In particular, the entire range uses R-32 refrigerant which, thanks to its thermodynamic performance, makes it possible to obtain much higher seasonal performance levels.

As its compressors are connected in parallel on the refrigerant circuit, the **AQUACIAT^{POWER}** easily and efficiently adjusts the cooling capacity to the system's needs. The self-adjusting Connect Touch control anticipates variations in load and starts only the number of compressors needed. This ensures optimum operation of the compressors and guarantees energy efficiency for the majority of the system's life.

In the high seasonal energy efficiency configuration, the **AQUACIAT^{POWER}** has variable-speed fan motor assemblies. This technology enables the machine's part-load performance to be improved, along with its seasonal performance (SEER, SEPR and SCOP).

The **(Seasonal Energy Efficiency Ratio (SEER))** measures the seasonal energy efficiency of liquid chillers **for comfort applications** by calculating the ratio between the annual cooling demand of the building and the chiller's annual energy demand. It takes into account the energy efficiency for each outdoor temperature weighted by the number of hours observed for each of these temperatures, using actual climate data.

The **SEER** is a new way of measuring the energy efficiency of liquid chillers for **comfort applications** over an entire year. The new indicator provides a more realistic overview of the cooling system's energy efficiency and its actual impact on the environment (Ecodesign regulation 2016/2281).

MEPS ⁽¹⁾ relating to EU ecodesign for chillers with air-cooled condensers		Level 1 (since 01/01/2018)	Level 2 (from 01/01/2021)
SEER for comfort Chillers < 400 kW	kWh/kWh	3,80	4,09
SEER for comfort Chillers > 400 kW	kWh/kWh	4,09	4,55

(1) Minimum energy performance standards set by EU member states to comply with the EU Ecodesign directive.

AQUACIAT^{POWER} LD comply with Ecodesign regulation 2016/2281



The **(Seasonal Energy Performance Ratio) (SEPR)** measures the seasonal energy efficiency of liquid chillers for **process applications** by calculating the ratio between the annual process cooling demand and the chiller's annual energy demand. It takes into account the energy efficiency at each outdoor temperature for the average European climate weighted by the number of hours observed for each of these temperatures.

The **SEPR** is a new way of measuring the energy efficiency of liquid chillers for **process applications** over an entire year. The new indicator provides a more realistic overview of the cooling system's energy efficiency and its actual impact on the environment (Ecodesign regulation 2015/1095 and 2016/2281).

MEPS ⁽¹⁾ relating to EU ECODESIGN for chillers with air-cooled condensers		Level 1 (since 01/07/2016)	Level 2 (since 01/07/2018)
SEPR for kWh/kWh < 300 kW medium temperature chillers	kWh/kWh	2,24	2,58
SEPR for kWh/kWh > 300 kW medium temperature chillers	kWh/kWh	2,80	3,22

MEPS ⁽¹⁾ relating to EU ECODESIGN for chillers with air-cooled condensers		Level 1 (since 01/01/2018)	Level 2 (from 01/01/2021)
SEPR for kWh/kWh < 400 kW process high temperature chillers	kWh/kWh	4,50	5,00
SEPR for kWh/kWh > 400 kW process high temperature chillers	kWh/kWh	5,00	5,50

(1) Minimum Efficiency Performance Standards: performance standards set by EU member states to comply with the EU Ecodesign directive. SCOP for the comfort heat pump (as per EU ecodesign directive)



SEASONAL PERFORMANCE IN HEATING MODE

The **(Seasonal Coefficient Of Performance) (SCOP)** measures the seasonal energy efficiency of heat pumps in heating mode.

The European Ecodesign directive considers the product's environmental impact throughout its entire life cycle. It defines the mandatory energy efficiency requirements for water chillers and heat pumps.

Products that do not meet the energy efficiency requirements set by the new directive will gradually be phased out of the market, forcing manufacturers to develop and offer more efficient products.

Like the SEER relating to water chillers, the new seasonal coefficient of performance (SCOP) resulting from this new European directive is used to evaluate the energy efficiency of heat pumps. Until now, only the COP has been used to measure energy efficiency in heating mode.

The COP was exclusively calculated using a single measuring point, and only took into account operation at full load, which did not represent the efficiency of the heat pump over an entire heating season.

The purpose of the SCOP is to characterise the seasonal efficiency of the heat pump by taking into account the efficiency at part load and full load established for several outdoor temperatures. The SCOP is the ratio between the building's annual heating demand and the annual electricity consumption of the heating system. It is measured in accordance with the EN14825 standard based on an average reference climate that takes into account several reference temperatures between -10 °C and +16 °C

■ Primary energy evaluation

In order to compare the energy efficiency of products using different energy sources, the Ecodesign directive introduced a new seasonal energy efficiency calculation known as η_s (Greek letter eta followed by the letter "s" for seasonal) and expressed as a percentage. For heat pumps, the SCOP (final energy) value is transposed to η_s (primary energy) by taking into account a conversion coefficient of 2.5 which corresponds to the average efficiency of the electrical production and various corrections for the responsiveness of the regulation system ($i = 3$ for air-to-water heat pumps).

$$\eta_s (\%) = \frac{\text{SCOP(kW/kW)} \times 100}{2,5} - \sum i \text{ corrections}$$

The minimum seasonal efficiency requirements to be met by low temperature heat pumps, set by the standard, are as follows:

MEPS ⁽¹⁾ relating to EU ecodesign for air-to-water heat pumps	Level 2 (since 09/2017)	
	Space & Hot Water 47/55 °C	Space Heating 30/35 °C
SCOP for heat pump < 400 kW	kWh/kWh 2,83	3,20
EtasS	110	125

AQUACIAT^{POWER} ILD units comply with Ecodesign regulation 813/2013.

Above 400 kW, AQUACIAT^{POWER} ILD units are subject to and comply with the SEER.

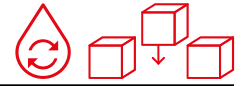

HYDRAULIC MODULE

■ The "ALL IN ONE" solution

The PLUG & COOL solution offered by AQUACIATPOWER

The hydraulic module contains all the hydraulic circuit components needed for the system to operate correctly:

- Buffer tank with 19-mm insulation, 550-litre capacity (option).
- Expansion tank (option):
 - 50 litres for models 602 to 900.
 - 80 litres for models 902 to 3500.
- Wide choice of pumps:
 - Single or dual pumps with operation time balancing and backup.
 - High- or low-pressure pumps.
 - Fixed-speed or variable-speed pumps.
- Water temperature and pressure sensors.
- Water filter.
- Relief valve.
- Drain circuit.
- Air bleed valve.
- Frost protection (option).

The components in the hydraulic system are carefully selected and factory assembled and tested to make the installation of the units simple and economical.

This ensures conditioning times, implementation times and space requirements are kept to a minimum.

■ Hydraulic module

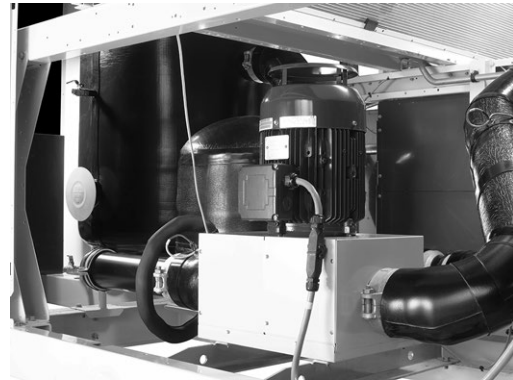

■ AQUACIATPOWER hydraulic module diagram

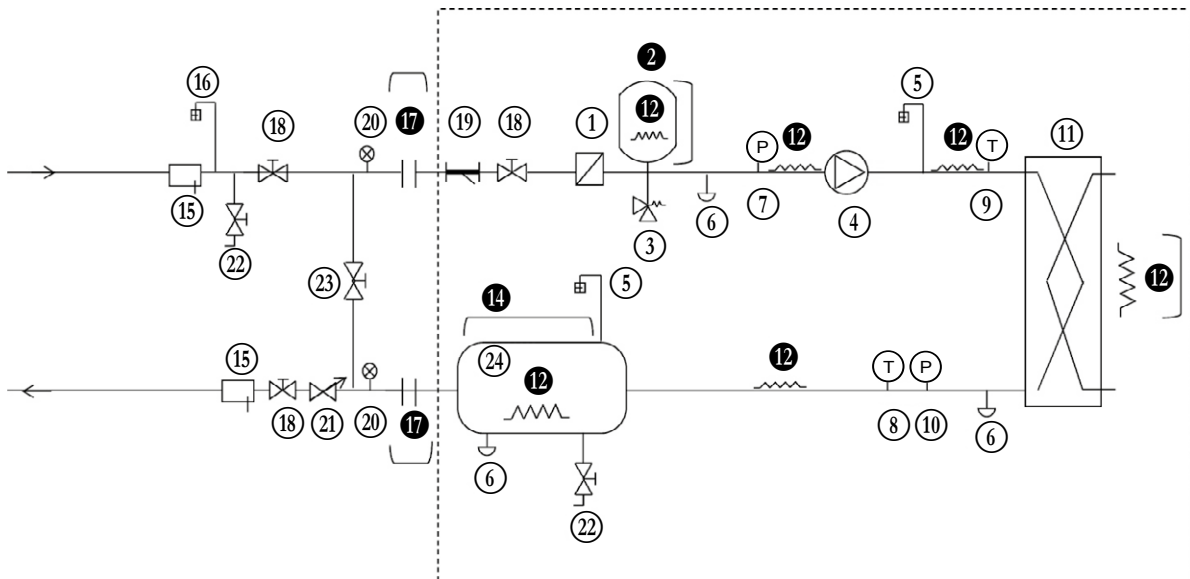

Components of the hydraulic module and the unit

- ① Screen filter
- ② Expansion tank
- ③ Relief valve
- ④ Circulating pump (single or dual)
- ⑤ Air vent
- ⑥ Water drain tap
- ⑦ Pressure sensor
Note: provides pressure information from the pump inlet
- ⑧ Temperature sensor
Note: provides temperature information from the water type heat exchanger outlet
- ⑨ Temperature sensor
Note: provides temperature information from the water type heat exchanger outlet
- ⑩ Pressure sensor
Note: provides pressure information from the water type heat exchanger outlet
- ⑪ Plate heat exchanger
- ⑫ Heater or heat trace cable for frost protection
- ⑬ Water type heat exchanger flow rate sensor
- ⑭ Water buffer tank module
- Option

Installation components

- ⑮ Pocket
 - ⑯ Air vent
 - ⑰ Flexible connection
 - ⑱ Shut-off valve
 - ⑲ 800 µm screen filter (Option - mandatory in the case of a unit without hydraulic module/included on the hydraulic version)
 - ⑳ Pressure gauge
 - ㉑ Water flow control valve
Note: not required if hydraulic module with variable-speed pump
 - ㉒ Charging valve
 - ㉓ Bypass valve for frost protection (if shut-off valves are closed (item 18) during winter)
 - ㉔ Buffer tank (if required)
 - Hydraulic module (unit with hydraulic module option)
- Notes:**
- The installation must be protected against frost.
 - The unit's hydraulic module and the water type heat exchanger may be protected (factory-fitted option) against frost using electric heaters and heat trace cables (12)
 - The pressure sensors are assembled on connections without Schrader. Depressurise and drain the system before any work.



VARIABLE FLOW PUMP

■ Description

The **AQUACIAT^{POWER}** may be equipped with one or two variable-speed pumps which save you energy by adjusting the electrical consumption of one pump to the actual requirements of a hydraulic system, in particular for oversized installations.

■ Simple to use

The "variable-speed pump" option is fully protected and fully built into the machine, which is installed outdoors to avoid the need for machine room work.

The assembly is factory-fitted and pre-set on the unit; it is therefore quick to install and reduces the cost of work, in particular because there is no water flow control valve on the unit's outlet.

The ability to adjust the water flow to your requirements means that the pump pressure can be adapted precisely to the actual pressure drop on the system when it is started up on-site.

■ Operating principle

Full load operation

A regulator, with a direct display of the flow rate and pressure on the Connect Touch screen, enables one pump (pump A in the example below) to be adapted, by lowering its pressure P1 to the requirements of system P2, to obtain the optimal water flow rate setpoint. Electricity bills for the pump consumption are proportionally reduced, guaranteeing a return on investment (ROI) in just a few years, compared to the same fixed-speed pump equipped with a single flow rate control valve.

Operation at part load

Three part load operating modes are available:

1 - Fixed speed

The control ensures the pump continuously runs at a constant speed, based on the capacity of the compressor(s). When the compressor is powered off, the Connect Touch "standby" function manages the electrical power consumed by the pump by reducing its speed to the minimum.

This provides energy savings of around 33%.

2 - Variable flow rate: Constant regulation of the pressure difference

The control continuously acts on the pump speed to ensure a constant pressure difference. This solution is suitable for installations with two-way valves. This control mode is used to ensure a uniform supply in each hydraulic circuit to make sure that each terminal unit operates at a satisfactory pressure

3 - Variable flow rate: Constant regulation of the temperature difference

The regulation maintains a constant temperature difference whatever the load rate of the unit by reducing the flow rate to the minimum acceptable limit. This control mode is suitable for most comfort applications.

This provides energy savings of around 66% for the pump in each of these last two operating modes

■ SOFT START

A SOFT START function prevents any current peaks when the pump is started up to protect the electrical system, thereby limiting the building's electricity use at peak times and ensuring the smooth operation of the pipework

■ STANDBY function

Lowering the speed when the compressors are on standby reduces the water flow rate to ensure the water loop is perfectly homogenised and the control temperature sensors are well irrigated. This reduces the pump's electricity consumption by around 80% during standby periods, which represents a significant proportion of the machine's normal operating time, in particular for air conditioning applications.

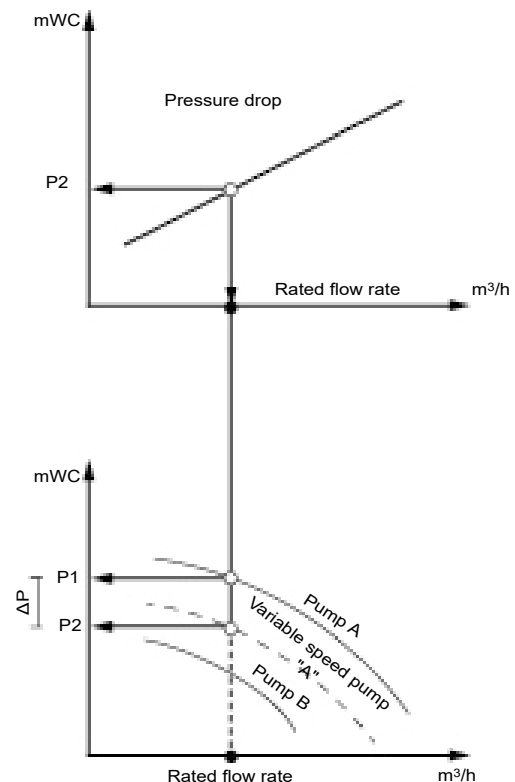

ENVIRONMENTAL RESPONSIBILITY

The **AQUACIAT^{POWER}** contributes to sustainable development via an environmentally responsible approach, aimed at balancing ecological and economic concerns. This enables it to meet the requirements of future European thermal regulations and to protect our environment for future generations.

The impact of an air conditioning system on global warming of the planet is in large part caused by CO₂ emissions released into the atmosphere when the electricity required to power the unit is produced (indirect effect) and in small part by CO₂ emissions linked to uncontrolled emissions of refrigerant with global warming potential into the atmosphere (direct effect).

With the **AQUACIAT^{POWER}**, it's a win-win situation: its low charge of R-32 refrigerant with low GWP reduces the direct environmental impact by 80% while reducing the indirect environmental impact thanks to its high energy performance.

■ 77% reduction in the direct environmental impact (refrigerant)

This performance is the result of the high-quality components used, which have all been rigorously selected:

- R-32 refrigerant with low environmental impact (Ozone depletion potential =0, Global warming potential =675)
- Aluminium micro-channel coil on LD chiller versions with a 40% reduction in refrigerant charge compared to a conventional coil
- New generation of copper tube coil-aluminium fins on ILD heat pump versions with a 30% reduction in refrigerant charge compared to a conventional coil
- Asymmetrical brazed-plate heat exchanger (BPHE) with a reduction in the refrigerant charge compared to a shell and tube heat exchanger
- Systematic tightness check of units in leak detection cabinets at end of line production

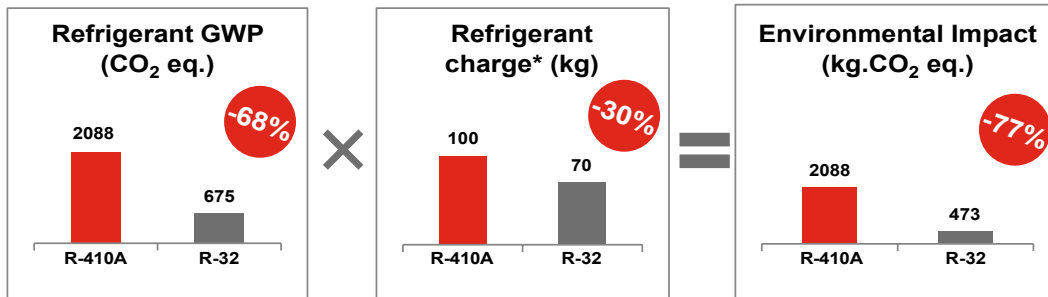

To conclude, the potential direct impact of the **AQUACIAT^{POWER}** on the environment with R-32 refrigerant is reduced by 77% compared to the previous generation R-410A.

■ Reduced indirect environmental impact (Energy)

The high energy performance offered by the **AQUACIAT^{POWER}** R-32 enables energy consumption to be greatly reduced, thereby cutting energy bills for the user whilst reducing the unit's carbon footprint.

The seasonal efficiency of the **AQUACIAT^{POWER}** R-32 in cooling mode is 10% greater than the previous version with R-410A and 6% greater in heating mode.

In addition, the **AQUACIAT^{POWER}** unit with R-32 refrigerant can be equipped with a variable-speed pump with constant or variable water flow control to significantly reduce pumping energy costs.

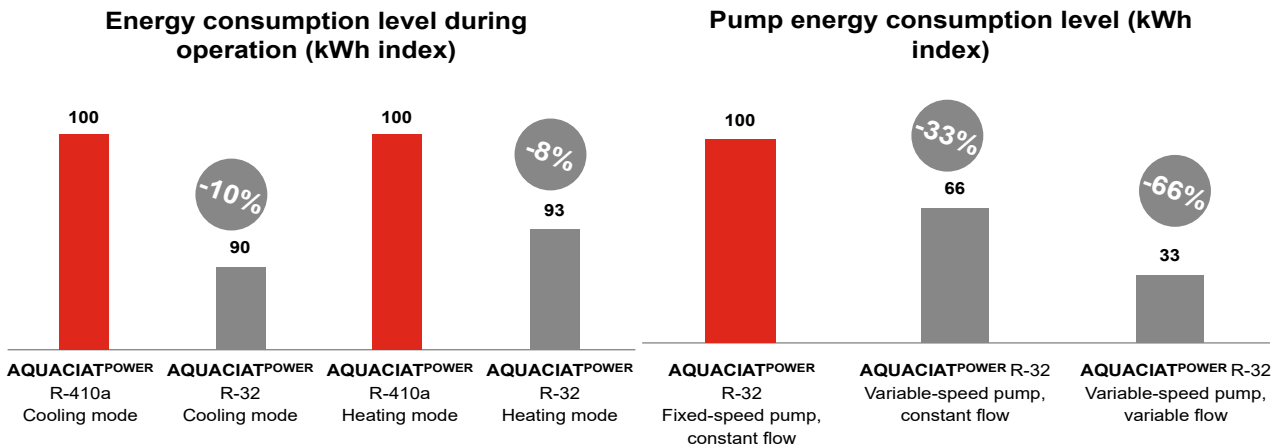

ENVIRONMENTAL RESPONSIBILITY

This performance is the result of the high-quality components used, which have all been rigorously selected:

- R-32 refrigerant with high energy performance,
- New generation of scroll compressors optimised for R-32 refrigerant
- Asymmetrical brazed-plate heat exchanger with extremely low water-side pressure drops enabling a reduction in pump electricity consumption
- Optional variable-speed pump enabling automatic adjustment of the rated water flow rate (disposal of the control valve), during operation and during unit shut down periods.

To conclude, the AQUACIAT^{POWER} unit with R-32 refrigerant and variable-speed pump greatly reduces the indirect environmental impact compared to the previous generation R-410A.

■ EcoPassport®

The PEP ecopassport® programme provides an international reference framework for procedures enabling manufacturers to report the environmental specifications of their products in the form of an environmental claim known as a Product Environmental Profile (PEP).

The PEP ecopassport® programme guarantees that PEPs are correctly drawn up, verified and reported in line with the requirements of the ISO 14025 and IEC/PAS 62545 standards.

The Life Cycle Analysis (LCA) PEP is the environmental identity card for an item of equipment which details the environmental impacts of the product during its life cycle according to eight mandatory indicators:

1. Global Warming Potential
2. Impact on the ozone layer
3. Acidification of soil and water
4. Eutrophication of water
5. Photochemical ozone creation
6. Abiotic resource depletion
7. Fresh water consumption
8. Total use of primary energy during the life cycle

Products with certified environmental profiles are used to support methods to assess building sustainability such as BREEAM, LEED. BREEAM, LEED gives additional recognition for materials with robust environmental product declaration types using manufacturer data.

CIAT is the first HVAC manufacturer to provide the PEP for liquid chillers and heat pumps including not only the 8 mandatory indicators, but all 27 indicators.

The **AQUACIAT^{POWER} LD** PEP can be downloaded from the PEP ecopassport® website: <http://www.pep-ecopassport.org/fr/>



AVAILABLE OPTIONS

Options	Description	Advantages	LD	ILD
Corrosion protection, traditional coils	Fins made of pre-treated aluminium (polyurethane and epoxy)	Improved corrosion resistance, recommended for moderate marine and urban environments	No	•
Low-temperature brine solution	Low temperature chilled water production down to -15 °C with ethylene glycol and down to -12 °C with propylene glycol.	Covers specific applications such as ice storage and industrial processes	•	No
XtraFan	Unit equipped with specific variable-speed fans: XtraFans (See specific chapter for maximum available static pressure according to size), each fan equipped with a connection flange and flexible sleeves	Ducted fan discharge, optimised fan speed control, based on the operating conditions and system characteristics	•	•
Very Low Noise	Acoustic compressor enclosure and low-speed fans	Noise level reduction for sensitive sites	•	•
Ultra Low Noise	Acoustic compressor enclosure, low-speed fans and enhanced sound insulation of main noise sources	Noise level reduction for sensitive sites	•	•
High ambient temperature	Unit equipped with a higher speed fan	Unit operating range extended to higher ambient temperatures	•	•
Protection grilles	Metallic protection grilles	Coil protection against possible impact	•	•
Soft starter per compressor	Electronic starter on each compressor	Reduced start-up current	•	•
Soft starter per circuit	Soft starter on each circuit	Economical solution for reduced start-up current	•	•
All year round cooling operation down to -20°C	Fanspeed control via frequency converter	Stable unit operation when the outdoor air temperature is between 0°C and -20°C	•	•
Water exchanger frost protection	Electric heater on the water type heat exchanger and the water duct	Water type heat exchanger module frost protection for an outdoor air temperature between 0 °C and -20 °C	•	•
Water manifold antifreeze protection	Electric heater and insulation on the water collection vessel pipes	Water collection vessel frost protection down to an outdoor temperature of -20 °C	No	2300R-4000R
Recovery condenser frost protection	Electric heater on the heat recovery exchanger	Heat recovery exchanger frost protection down to an outside temperature of -20 °C	•	No
Frost protection with glycol-free free cooling option	Electric resistance heater on the water type heat exchanger, and the hydraulic module	Water exchanger and hydraulic module frost protection down to -20°C outside temperature	•	No
Frost protection on the evaporator and hydraulic module with the Free Cooling Glycol Free option	Electric resistance heater on the water type heat exchanger and hydraulic module	Water type heat exchanger and hydraulic module frost protection down to -20°C outside temperature	•	No
Exchanger & hydraulic module frost protection	Electrical heaters on the water type heat exchanger, water pipes, hydraulic module and expansion tank	Water type heat exchanger and hydraulic module frost protection down to an outdoor air temperature of -20 °C	•	•
Exchanger & hydraulic frost protection with buffer tank	Electrical heaters on the water type heat exchanger, water pipes, hydraulic module, optional expansion tank and buffer tank	Water type heat exchanger and hydraulic module frost protection down to an outdoor air temperature of -20 °C	•	•
Partial heat recovery	Unit equipped with one desuperheater on each refrigerant circuit	Production of free high-temperature hot water simultaneously with chilled water production (or hot water for heat pump)	•	•
Total heat recovery	Unit equipped with additional heat exchanger in series with the condenser coils.	Production of free hot water, adjustable on demand	•	No
Master/slave operation	Unit equipped with supplementary water outlet temperature sensor kit (to be field installed) allowing master/slave operation of two units connected in parallel	Optimised operation of two units connected in parallel operation with operation time balancing	•	•

• ALL MODELS

Refer to the selection tool to find out which options are not compatible.

AVAILABLE OPTIONS

Options	Description	Advantages	LD	ILD
Compressor suction and discharge valves	Shut-off valves on the common compressor suction and discharge pipes	Simplified maintenance. Possibility to store the refrigerant charge in the cooler or condenser side during servicing	•	•
Evaporator single HP pump	High pressure fixed speed water pump. (optional expansion vessel and built-in hydraulic safety components available)	Quick and easy installation (plug & play)	0602R-1400R	0602R-2000R
Evaporator dual HP pump	Dual high pressure fixed speed water pump. (optional expansion vessel and built-in hydraulic safety components available)	Quick and easy installation (plug & play)	0602R-1400R	0602R-2000R
Evaporator single LP pump	Single low pressure fixed speed water pump. (optional expansion vessel and built-in hydraulic safety components available)	Quick and easy installation (plug & play)	0602R-1400R	0602R-2000R
LP dual-pump hydraulic module	Dual low pressure water pump, fixed speed. (optional expansion vessel and built-in hydraulic safety components available)	Quick and easy installation (plug & play)	0602R-1400R	0602R-2000R
HP single-pump (variable speed)	Single high-pressure water pump, water filter, electronic water flow control, pressure sensors. Multiple variable water flow control options (optional expansion vessel and built-in hydraulic safety components available)	Quick and easy installation (plug & play), significant reduction in pumping energy consumption level (more than two-thirds), precise water flow control, improved system reliability	•	•
Dual HP pump (variable speed)	Dual high pressure water pump with variable speed drive (VSD), pressure transducers. Multiple options for water flow control. For more details, refer to the relevant section	Quick and easy installation (plug & play), significant reduction in pumping energy consumption level (more than two-thirds), precise water flow control, improved system reliability	•	•
High nominal energy efficiency	Higher air flow through the condenser coils improving heat exchange efficiency on the condenser	Energy cost reduction and extended operating envelope (full load operation at higher air temperature)	•	•
High seasonal energy efficiency (VSD)	Unit equipped with variable-speed fans (VSD)	Enhances the unit seasonal energy efficiency performance and reduces the noise emission thanks to a smooth fan speed variation.	•	•
High seasonal energy efficiency (EC)	Variable-speed fans with EC motors	Enhances the unit seasonal energy efficiency performance and reduces the noise emission thanks to a smooth fan speed variation.	•	•
High energy efficiency underfloor heating/cooling application	Optimisation of the refrigerant circuit and control for the underfloor heating/cooling system application	Improvement of performance and reduction of energy costs for the underfloor heating/cooling application	No	•
Lon gateway	Two-directional communication board complying with Lon Talk protocol	Connects the unit by communication bus to a centralised building management system	•	•
Bacnet over IP	Two-directional high-speed communication using BACnet protocol over Ethernet network (IP)	Easy and high-speed connection by Ethernet line to a BMS. Allows access to multiple unit parameters	•	•
Energy management module	EMM Control board with additional inputs/outputs. See Energy Management Module section	Extended remote control capabilities (setpoint reset, ice storage end, demand limits, boiler on/off command...)	•	•
Contact for refrigerant leak detection	0-5 V signal to report any refrigerant leakage in the unit directly (the leak detector itself must be supplied by the customer)	Immediate customer notification of refrigerant losses to the atmosphere, allowing timely corrective actions	•	•
Phase controller	Phase controller on the power supply	Reinforced protection of the unit by monitoring rotation, the absence and asymmetry of the phases, and the over- or under-voltage of the electrical network	•	•
Compliance with Russian regulations	EAC certification	Compliance with Russian regulations	•	•

• ALL MODELS

Refer to the selection tool to find out which options are not compatible.

AVAILABLE OPTIONS

Options	Description	Advantages	LD	ILD
Coil defrost resistance heaters	Electric heaters under the coils and the condensate pans	Prevents frost formation on the coils; compulsory in heating mode if the outdoor temperature is below 0 °C	No	•
Insulation of the evaporator inlet/outlet refrigerant lines	Thermal insulation of the evaporator inlet/outlet refrigerant lines, with UV-resistant flexible connection and insulation	Prevents condensation on the evaporator inlet/outlet refrigerant lines	•	•
Protect2 anti-corrosion protection	Coating applied using a conversion process which modifies the surface of the aluminium producing a coating that is integral to the coil. Complete immersion in a bath to ensure 100% coverage. No heat transfer variation, tested to withstand more than 4000 hours of salt spray as per ASTM B117	Protect2 Improved corrosion resistance of the MCHE coils by 2, recommended for use in moderately corrosive environments	•	No
Anti-corrosion protection on FreeCooling coils	Same anticorrosion treatment as on MCHE condenser coils	Improved corrosion resistance, recommended for use in moderately corrosive environments.	•	No
Protect4 anti-corrosion protection	Extremely durable and flexible epoxy polymer coating applied on micro channel coils by electro coating process, final UV protective topcoat. Minimal heat transfer variation, tested to withstand more than 6000 hours of constant neutral salt spray as per ASTM B117, improved impact resistance as per ASTM D2794	Protect4 Improved corrosion resistance of the MCHE coils by 4, recommended for use in corrosive environments	•	No
Flanged evaporator water connection kit	Victaulic piping connections with flanged joints	Easy installation	•	•
Compressor enclosure	Compressor with enclosure	Improved aesthetics, compressor protection against external elements (dust, sand, water...)	•	•
EMC class. C2, as per EN 61800-3	Additional RFI filters on the unit power line	Reduces electromagnetic interference in accordance with the emission level required by category C2 to allow use in the first environment ("residential environment")	•	•
230 V electrical plug	230 VAC power source provided with plug socket and transformer (180 VA, 0.8 A)	Enables connection of a laptop or an electrical device during system start-up or maintenance	•	•
Expansion tank	6-bar expansion tank built into the hydraulic module (requires hydraulic module option)	Easy and fast installation (plug & play), & protection of closed water systems from excessive pressure	•	•
Electric energy meter	Electric energy meter. Display of energy consumption, instantaneous (U, V, I) and cumulative (kWh) on the machine interface, data available on the communication buses	Enables acquisition, monitoring (remote on CMS/BMS) of energy used.	•	•
Ultra-fast full capacity recovery	Built-in capacity module to allow an ultra-rapid restart whilst maintaining the unit's reliability.	Full capacity recovery in less than 10 minutes 30 seconds after a power failure of less than 10 minutes. Matches requirements of typical critical mission applications. (process, data centres)	•	No
Screwed water connection sleeves for desuperheater	DSH connections with screw connection sleeves	Easy to install. Allows unit connection to a screw connector	•	•
Free cooling (total)	Free cooling hydraulic coils on the two refrigerant circuits	Energy savings for applications which require cooling all year round (e.g.: industrial processes, data centres)	•	No

• ALL MODELS

Refer to the selection tool to find out which options are not compatible.

AVAILABLE OPTIONS

Options	Description	Advantages	LD	ILD
Free cooling (partial)	Free cooling hydraulic coils on a refrigerant circuit	Energy savings for applications with reduced demand for cooling in the winter (e.g. office space with computer room, meeting rooms)	•	No
Free Cooling Glycol Free (Total)	Free cooling hydraulic coils on both refrigerant circuits and decoupling exchanger.	Energy savings for applications which require cooling all year round (e.g.: industrial processes, data centres, etc.) Glycol-free operation	•	No
Water buffer tank module	Built-in water buffer tank module	Avoids short cycle on compressors and ensures stable water in the loop	•	•
Anti-vibration mounts	Elastomer anti-vibration mounts to be placed under the unit (material classified as fire class B2 according to DIN 4102).	Isolate the unit from the building, prevent the transmission of vibrations and associated noise to the building. Must be used in conjunction with a flexible connection on the water side	•	•
Exchangers flexible coupling connection	Flexible connections on the exchanger water side	Easy to install. Limits the transmission of vibrations to the water network	•	•
Exchanger water filter	Water filter	Eliminates dust in the water network	•	•
Free cooling dry cooler management	Control and connections to an Opera or Vextra free cooling dry cooler fitted with optional FC control box	Easy system management, extended control capabilities to a dry cooler used in free cooling mode	•	No
Desuperheater flexible couplings	Flexible connections on the desuperheater water side	Easy to install. Limits the transmission of vibrations to the water network	•	•
Water manifold	Pipe system providing a single hydraulic connection point	Easy installation	No	2300R-4000R
Installation or application process outside Europe	Specific management of option compatibility	Permits non-standard option compatibility for HVAC application in the EU	•	No
Compliance with Moroccan regulations	Specific regulatory documentation	Compliance with Moroccan regulations	•	•
Delivered wrapped in plastic film	Unit wrapped in a plastic cover and strapped onto a wooden pallet.	Protects against dust and external soiling of the unit during storage and transport.	•	•
IT neutral system	Specific earthing to insulate the earth neutral point.	The unit still operates after the first electrical isolation fault to guarantee continuity of operation (industrial processes, data centres, hospitals).	•	•

• ALL MODELS

Refer to the selection tool to find out which options are not compatible.



TECHNICAL SPECIFICATIONS - COOLING ONLY

AQUACIAT ^{POWER} LD			0602R-A	0650R-A	0750R-A	0900R-A	1100R-A	1200R-A	1350R-A	1400R-A	1600R-A	
Cooling												
Standard unit Full load performances*	CA1	Rated capacity	kW	165	180	198	217	256	296	328	361	394
		EER	kW/kW	3,05	3,24	3,04	3,02	2,81	2,96	2,86	2,94	2,86
Seasonal energy efficiency**		SEER_{12/7°C} Comfort low temp.	kWh/kWh	4,49	4,64	4,45	4,47	4,35	4,70	4,67	4,62	4,89
		ηs cool_{12/7°C}	%	169	181	178	176	171	185	183	183	193
		SEER_{23/18°C} Comfort medium temp.	kWh/kWh	5,27	5,52	5,22	5,26	4,99	5,66	5,55	5,43	5,80
		SEPR _{12/7°C} Process high temp.	kWh/kWh	5,27	5,42	5,34	5,19	5,14	5,44	5,47	5,60	5,63
		SEPR_{-2/-8°C} Process medium temp.	kWh/kWh	3,06	3,11	3,08	3,00	3,04	3,09	3,14	3,09	3,16
Part Load Integrated Values		IPLV.SI	kW/kW	5,06	5,16	5,04	5,16	5,08	5,25	5,23	5,21	5,52
Unit + Rated & Seasonal high performance options Full load performances*	CA1	Rated capacity	kW	172	187	206	227	270	311	346	380	416
		EER	kW/kW	3,20	3,36	3,21	3,16	3,03	3,15	3,09	3,14	3,10
Seasonal energy efficiency**		SEER_{12/7°C} Comfort low temp.	kWh/kWh	4,82	5,02	4,84	4,94	4,79	5,25	5,15	5,09	5,11
		ηs cool_{12/7°C}	%	190	198	191	195	189	207	203	201	201
		SEER_{23/18°C} Comfort medium temp.	kWh/kWh	5,98	6,23	5,93	5,99	5,69	6,35	6,17	6,13	6,07
		SEPR _{12/7°C} Process high temp.	kWh/kWh	6,30	6,61	6,42	6,13	5,97	6,30	6,24	6,36	6,30
		SEPR_{-2/-8°C} Process medium temp.	kWh/kWh	3,48	3,60	3,54	3,41	3,41	3,51	3,56	3,50	3,57
Sound levels												
Unit + High temperature option/ Rated high performance												
		Sound power ⁽¹⁾	dB(A)	91,0	91,5	91,5	92,0	92,0	93,0	93,0	93,5	93,5
		Sound pressure at 10 m ⁽²⁾	dB(A)	58,5	59,5	59,5	60,0	60,0	60,5	60,5	61,0	61,5
Standard unit												
		Sound power ⁽¹⁾	dB(A)	88,5	89,0	89,0	89,5	89,5	90,5	90,5	91,0	91,0
		Sound pressure at 10 m ⁽²⁾	dB(A)	56,5	57,0	57,0	57,5	57,5	58,5	58,5	59,0	58,5
Unit + Very Low Noise option												
		Sound power ⁽¹⁾	dB(A)	85,5	85,5	85,5	86,5	86,5	87,5	87,5	88,0	88,0
		Sound pressure at 10 m ⁽²⁾	dB(A)	53,0	53,5	53,5	54,5	54,5	55,5	55,5	55,5	56,0
Unit + Ultra Low Noise option												
		Sound power ⁽¹⁾	dB(A)	83,5	83,5	83,5	84,5	84,5	85,5	85,5	86,0	86,0
		Sound pressure at 10 m ⁽²⁾	dB(A)	51,5	51,5	51,5	52,5	52,5	53,5	53,5	53,5	53,5

* In accordance with EN14511-3:2022.
 ** In accordance with EN14825:2022, average climate conditions
 CA1 Cooling mode conditions: evaporator water inlet/outlet temperature 12 °C/7 °C, outdoor air temperature 35 °C, evaporator fouling factor 0 m². k/W
ηs cool_{12/7°C} & SEER_{12/7°C} Values in bold comply with Ecodesign Regulation (EU) No. 2016/2281 for Comfort applications
SEER_{23/18°C} Values in bold comply with Ecodesign Regulation (EU) No. 2016/2281 for Comfort applications
 SEPR_{12/7°C} Values calculated in accordance with EN 14825:2022
 SEPR_{-2/-8°C} Values calculated in accordance with EN 14825:2022
 IPLV.SI Calculated as per AHRI standard 551-591.
 (1) In dB ref=10⁻¹² W, 'A' weighted. Declared dual-number noise emission value in accordance with ISO 4871 with an uncertainty of +/-3 dB(A). Measured in accordance with ISO 9614-1 and certified by Eurovent.
 (2) In dB ref 20 μPa, (A) weighting. Declared dual-number noise emission value in accordance with ISO 4871 with an uncertainty of +/-3 dB(A). For information, calculated from the sound power Lw(A).



Eurovent certified values



TECHNICAL SPECIFICATIONS - COOLING ONLY

AQUACIATPOWER LD		0602R-A	0650R-A	0750R-A	0900R-A	1100R-A	1200R-A	1350R-A	1400R-A	1600R-A
Dimensions										
Standard unit										
Length	mm	2410	2410	2410	2410	2410	3604	3604	3604	3604
Width	mm	2253	2253	2253	2253	2253	2253	2253	2253	2253
Height	mm	2324	2324	2324	2324	2324	2324	2324	2324	2324
Unit + water buffer tank module option										
Length	mm	3604	3604	3604	3604	3604	4798	4798	4798	4798
Operating weight ⁽³⁾										
Standard unit	kg	1349	1397	1397	1521	1556	1995	2049	2211	2269
Unit + Ultra Low Noise option	kg	1453	1501	1501	1656	1690	2153	2208	2394	2452
Unit + Ultra Low Noise + HP dual-pump hydraulic module option	kg	1588	1636	1636	1791	1837	2302	2403	2589	2646
Unit + Ultra Low Noise + HP dual-pump hydraulic module + Water buffer tank module option	kg	2571	2619	2619	2774	2819	3288	3389	3575	3632
Compressors		Hermetic Scroll 48.3 r/s								
Circuit A		1	1	1	2	2	2	2	3	3
Circuit B		2	2	2	2	2	3	3	3	3
Number of power stages		3	3	3	4	4	5	5	6	6
Unit PED category		III								
Refrigerant⁽³⁾		R-32 / A2L/ GWP= 675 in accordance with ARI4								
Circuit A	kg	6,3	9,4	9,4	11,1	11,5	12,2	13,0	17,7	18,5
	tCO ₂ e	4,2	6,3	6,3	7,5	7,8	8,2	8,8	11,9	12,5
Circuit B	kg	11,1	11,1	11,1	11,1	11,5	17,1	17,9	18,5	19,3
	tCO ₂ e	7,5	7,5	7,5	7,5	7,8	11,5	12,0	12,5	13,0
Oil										
Circuit A	l	6,6	6,6	6,6	13,2	13,2	13,2	13,2	19,8	19,8
Circuit B	l	13,2	13,2	13,2	13,2	13,2	19,8	19,8	19,8	19,8
Capacity control		Connect'Touch								
Minimum capacity	%	33	33	33	25	25	20	20	17	17
Condenser		All-aluminium micro-channel coils (MCHE)								
Fans		Axial with rotating impeller								
Standard unit										
Quantity		3	4	4	4	4	5	5	6	6
Maximum total air flow	l/s	11790	15720	15720	15720	15720	19650	19650	23580	23580
Maximum rotation speed	r/s	12	12	12	12	12	12	12	12	12
Evaporator		Dual-circuit plate heat exchanger								
Water volume	l	15	15	15	19	27	27	35	44	44
Max. water-side operating pressure without hydraulic module	kPa	1000	1000	1000	1000	1000	1000	1000	1000	1000
Hydraulic module (option)		Pump, Victaulic screen filter, relief valve, water and air vent valve, pressure sensors								
Pump		Centrifugal pump, monocell, 48.3 r/s, low- or high-pressure (as required), single or dual (as required)								
Expansion tank volume (Option)	l	50	50	50	50	50	80	80	80	80
Buffer tank volume (optional)	l	550	550	550	550	550	550	550	550	550
Max. water-side operating pressure with hydraulic module	kPa	400	400	400	400	400	400	400	400	400
Water connections with or without hydraulic module		Victaulic® type								
Connections	inches	3	3	3	3	3	4	4	4	4
External diameter	mm	88,9	88,9	88,9	88,9	88,9	114,3	114,3	114,3	114,3
Casing paint colour		Colour code RAL 7035 & 7024								

- (1) In dB ref=10⁻¹² W, 'A' weighted. Declared dual-number noise emission value in accordance with ISO 4871 with an uncertainty of +/-3 dB(A). Measured in accordance with ISO 9614-1 and certified by Eurovent.
- (2) In dB ref 20 µPa, (A) weighting. Declared dual-number noise emission value in accordance with ISO 4871 with an uncertainty of +/-3 dB(A). For information, calculated from the sound power Lw(A).
- (3) Values are guidelines only. Refer to the unit name plate.



TECHNICAL SPECIFICATIONS - COOLING ONLY

AQUACIATPOWER LD			1750R-A	1800R-A	2000R-A	2200R-A	2400R-A	2650R-A	2800R-A	2950R-A	3200R-A	3500R-A	
Cooling													
Standard unit Full load performances*	CA1	Rated capacity	kW	428	458	523	586	645	688	743	765	836	889
		EER	kW/kW	2,94	2,85	2,85	2,94	2,94	2,83	2,85	2,81	2,77	2,66
Seasonal energy efficiency**		SEER_{12/7°C} Comfort low temp.	kWh/kWh	5,08	5,03	4,95	5,08	5,16	5,05	5,17	5,13	4,98	4,86
		η_{s cool} 12/7°C	%	200	198	195	200	204	199	204	202	196	191
		SEER_{23/18°C} Comfort medium temp.	kWh/kWh	5,99	5,91	5,98	6,26	6,44	6,20	6,43	6,34	6,10	5,85
		SEPR _{12/7°C} Process high temp.	kWh/kWh	5,58	5,58	5,54	5,52	5,58	5,44	5,46	5,41	5,36	5,22
		SEPR_{-2/-8°C} Process medium temp.	kWh/kWh	3,13	3,15	3,15	3,54	3,46	3,49	3,44	3,46	3,41	3,44
Part Load integrated values		IPLV.SI	kW/kW	5,68	5,63	5,60	5,75	5,71	5,60	5,74	5,71	5,63	5,51
Unit + Rated & Seasonal high performance options Full load performances*	CA1	Rated capacity	kW	451	484	553	616	677	726	782	807	882	944
		EER	kW/kW	3,15	3,09	3,08	3,16	3,14	3,06	3,07	3,04	3,00	2,92
Seasonal energy efficiency**		SEER_{12/7°C} Comfort low temp.	kWh/kWh	5,28	5,24	5,29	5,32	5,32	5,20	5,33	5,30	5,31	5,18
		η_{s cool} 12/7°C	%	208	207	209	210	210	205	210	209	209	204
		SEER_{23/18°C} Comfort medium temp.	kWh/kWh	6,33	6,23	6,32	6,56	6,51	6,28	6,54	6,47	6,56	6,32
		SEPR _{12/7°C} Process high temp.	kWh/kWh	6,41	6,32	6,27	6,27	6,33	6,14	6,25	6,18	6,07	5,86
		SEPR_{-2/-8°C} Process medium temp.	kWh/kWh	3,55	3,55	3,55	3,91	3,82	3,83	3,79	3,80	3,74	3,74
Sound levels													
Unit + High temperature option/ Rated high performance													
Sound power ⁽¹⁾			dB(A)	94,0	94,0	94,5	97,5	97,5	98,0	98,0	98,5	98,5	99,0
Sound pressure at 10 m ⁽²⁾			dB(A)	61,5	61,5	62,0	65,0	65,0	66,0	65,0	66,0	66,0	66,5
Standard unit													
Sound power ⁽¹⁾			dB(A)	91,5	91,5	92,0	96,5	96,5	97,0	97,0	97,5	97,5	98,0
Sound pressure at 10 m ⁽²⁾			dB(A)	59,5	59,0	60,0	64,0	64,0	64,5	65,0	65,0	65,0	65,5
Unit + Very Low Noise option													
Sound power ⁽¹⁾			dB(A)	88,5	88,5	89,0	92,5	92,5	93,0	93,0	93,5	93,5	94,5
Sound pressure at 10 m ⁽²⁾			dB(A)	56,0	56,5	57,0	60,5	60,0	60,5	60,0	61,0	60,5	61,5
Unit + Ultra Low Noise option													
Sound power ⁽¹⁾			dB(A)	86,5	86,5	87,0	90,0	90,0	90,5	90,5	90,5	90,5	91,0
Sound pressure at 10 m ⁽²⁾			dB(A)	54,5	54,0	55,0	57,5	57,5	58,0	58,0	57,5	58,0	58,5

* In accordance with EN14511-3:2022.
 ** In accordance with EN14825:2022, average climate conditions
 CA1 Cooling mode conditions: evaporator water inlet/outlet temperature 12 °C/7 °C, outdoor air temperature 35 °C, evaporator fouling factor 0 m², k/W
η_{s cool} 12/7°C & SEER_{12/7°C} Values in bold comply with Ecodesign Regulation (EU) No. 2016/2281 for Comfort applications
SEER_{23/18 °C} Values in bold comply with Ecodesign Regulation (EU) No. 2016/2281 for Comfort applications
 SEPR_{12/7 °C} Values calculated in accordance with EN 14825:2022
 SEPR_{-2/-8 °C} Values calculated in accordance with EN 14825:2022
 IPLV.SI Calculated as per AHRI standard 551-591.
 (1) In dB ref=10⁻¹² W, 'A' weighted. Declared dual-number noise emission value in accordance with ISO 4871 with an uncertainty of +/-3 dB(A). Measured in accordance with ISO 9614-1 and certified by Eurovent.
 (2) In dB ref 20 μPa, (A) weighting. Declared dual-number noise emission value in accordance with ISO 4871 with an uncertainty of +/-3 dB(A). For information, calculated from the sound power Lw(A).



Eurovent certified values



TECHNICAL SPECIFICATIONS - COOLING ONLY

AQUACIATPOWER LD		1750R-A	1800R-A	2000R-A	2200R-A	2400R-A	2650R-A	2800R-A	2950R-A	3200R-A	3500R-A
Dimensions											
Standard unit											
Length	mm	4798	4798	4798	5992	5992	5992	7186	7186	7186	7186
Width	mm	2253	2253	2253	2253	2253	2253	2253	2253	2253	2253
Height	mm	2324	2324	2324	2324	2324	2324	2324	2324	2324	2324
Unit + water buffer tank module option											
Length	mm	5992	5992	5992	7186	7186	7186	8380	8380	8380	8380
Operating weight ⁽³⁾											
Standard unit	kg	2697	2722	2927	3265	3511	3511	4042	4042	4291	4291
Unit + Ultra Low Noise option	kg	2904	2930	3158	3434	3703	3703	4260	4260	4535	4535
Unit + Ultra Low Noise + HP dual-pump hydraulic module option	kg	3138	3164	3430	3743	4013	4013	4650	4650	4925	4925
Unit + Ultra Low Noise + HP dual-pump hydraulic module + Water buffer tank module option	kg	4131	4156	4421	4750	5020	5020	5671	5671	5946	5946
Compressors											
Hermetic Scroll 48.3 r/s											
Circuit A		3	3	4	2	3	3	3	3	4	4
Circuit B		4	4	4	3	3	3	4	4	4	4
Number of power stages		7	7	8	5	6	6	7	7	8	8
Unit PED category											
		IV	IV	IV	III	III	III	IV	IV	IV	IV
Refrigerant⁽³⁾											
R-32 / A2L/ GWP= 675 in accordance with ARI4											
Circuit A	kg	18,8	19,1	24,4	23,0	24,5	24,5	27,3	27,3	30,4	30,4
	tCO ₂ e	12,7	12,9	16,5	15,5	16,5	16,5	18,4	18,4	20,5	20,5
Circuit B	kg	24,5	24,9	25,4	24,5	24,5	24,5	30,4	30,4	30,4	30,4
	tCO ₂ e	16,5	16,8	17,1	16,5	16,5	16,5	20,5	20,5	20,5	20,5
Oil											
Circuit A	l	19,8	19,8	26,4	13,2	19,8	19,8	19,8	19,8	26,4	26,4
Circuit B	l	26,4	26,4	26,4	19,8	19,8	19,8	26,4	26,4	26,4	26,4
Capacity control											
Connect'Touch											
Minimum capacity	%	14	14	13	20	17	17	14	14	13	13
Condenser											
All-aluminium micro-channel coils (MCHE)											
Fans											
Axial with rotating impeller											
Standard unit											
Quantity		7	7	8	9	10	10	11	11	12	12
Maximum total air flow	l/s	27510	27510	31440	35370	39300	39300	43230	43230	47160	47160
Maximum rotation speed	r/s	12	12	12	12	12	12	12	12	12	12
Evaporator											
Dual-circuit plate heat exchanger											
Water volume	l	44	47	53	73	73	73	84	84	84	84
Max. water-side operating pressure without hydraulic module	kPa	1000	1000	1000	1000	1000	1000	1000	1000	1000	1000
Hydraulic module (option)											
Pump, Victaulic screen filter, relief valve, water and air vent valve, pressure sensors											
Pump		Centrifugal pump, monocell, 48.3 r/s, low- or high-pressure (as required), single or dual (as required)									
Expansion tank volume (Option)	l	80	80	80	80	80	80	80	80	80	80
Buffer tank volume (optional)	l	550	550	550	550	550	550	550	550	550	550
Max. water-side operating pressure with hydraulic module	kPa	400	400	400	400	400	400	400	400	400	400
Water connections with or without hydraulic module											
Victaulic® type											
Connections	inches	4	4	4	5	5	5	5	5	5	5
External diameter	mm	114,3	114,3	114,3	139,7	139,7	139,7	139,7	139,7	139,7	139,7
Casing paint colour											
Colour code RAL 7035 & 7024											

- (1) In dB ref=10⁻¹² W, 'A' weighted. Declared dual-number noise emission value in accordance with ISO 4871 with an uncertainty of +/-3 dB(A). Measured in accordance with ISO 9614-1 and certified by Eurovent.
- (2) In dB ref 20 µPa, (A) weighting. Declared dual-number noise emission value in accordance with ISO 4871 with an uncertainty of +/-3 dB(A). For information, calculated from the sound power Lw(A).
- (3) Values are guidelines only. Refer to the unit name plate.



TECHNICAL SPECIFICATIONS - REVERSIBLE HEAT PUMP

AQUACIATPOWER ILD	0602R	0700R	0800R	0900R	1000R	1150R
-------------------	-------	-------	-------	-------	-------	-------

Heating

Standard unit Full load performances*	HA1	Rated capacity	kW	178	197	237	256	275	317
		COP	kW/kW	3,88	3,80	3,84	3,84	3,82	3,82
	HA2	Rated capacity	kW	173	192	231	250	269	310
		COP	kW/kW	3,16	3,09	3,14	3,12	3,11	3,10
Energy efficiency efficiency**	HA1	SCOP_{30/35°C}	kWh/kWh	3,44	3,45	3,39	3,47	3,48	3,57
		η_{s heat 30/35°C}	%	135	135	133	136	136	140
		P _{rated}	kW	139	155	186	200	217	250
Unit + Rated & Seasonal high performance options Full load performances*	HA1	Rated capacity	kW	178	197	237	256	275	317
		COP	kW/kW	3,88	3,80	3,84	3,84	3,82	3,82
	HA1	SCOP_{30/35°C}	kWh/kWh	3,67	3,66	3,74	3,77	3,80	3,87
		η_{s heat 30/35°C}	%	144	143	147	148	149	152
	HA1	P _{rated}	kW	138	155	185	200	216	250

Cooling

Standard unit Full load performances*	CA1	Rated capacity	kW	155	171	204	223	239	285
		EER		2,73	2,55	2,73	2,63	2,56	2,66
Energy efficiency efficiency**	CA1	SEER _{12/7°C} Comfort low temp.	kWh/kWh	4,17	4,01	4,18	4,08	4,04	4,48
		SEPR _{12/7°C} Process high temp.	kWh/kWh	4,68	4,51	4,64	4,52	4,50	4,83
Unit + Rated & Seasonal high performance options Full load performances*	CA1	Rated capacity	kW	164	181	215	236	254	302
		EER	kW/kW	2,87	2,72	2,86	2,80	2,76	2,85
Energy efficiency efficiency**	CA1	SEER _{12/7°C} Comfort low temp.	kWh/kWh	4,41	4,23	4,48	4,41	4,34	4,78
		SEPR _{12/7°C} Process high temp.	kWh/kWh	5,47	5,23	5,41	5,23	5,15	5,49

Sound levels

Unit + High temperature option/Rated high performance									
Sound power ⁽¹⁾	dB(A)	90,5	91,0	91,5	92,0	92,0	93,0		
Sound pressure at 10 m ⁽²⁾	dB(A)	58,5	59,0	59,5	60,0	60,0	61,0		
Standard unit									
Sound power ⁽¹⁾	dB(A)	88,0	88,5	89,0	89,5	89,5	90,5		
Sound pressure at 10 m ⁽²⁾	dB(A)	55,5	56,0	56,5	57,0	57,0	58,0		
Unit + Very Low Noise option⁽³⁾									
Sound power ⁽¹⁾	dB(A)	85,0	86,0	86,5	87,0	87,0	88,0		
Sound pressure at 10 m ⁽²⁾	dB(A)	53,0	53,5	54,0	54,5	54,5	55,5		
Unit + Ultra Low Noise option⁽³⁾									
Sound power ⁽¹⁾	dB(A)	83,0	84,0	84,5	85,0	85,0	86,0		
Sound pressure at 10 m ⁽²⁾	dB(A)	51,0	52,0	52,5	53,0	53,0	54,0		

- * In accordance with EN14511-3:2022.
- ** In accordance with EN14825:2022, average climate conditions
- HA1 Heating mode conditions: Water type heat exchanger water inlet/outlet temperature 30 °C/35 °C, outdoor air temperature tdb/twb = 7 °C db/6 °C wb, evaporator fouling factor 0 m². k/W
- HA2 Heating mode conditions: Water type heat exchanger water inlet/outlet temperature 40 °C/45 °C, outdoor air temperature tdb/twb = 7 °C db/6 °C wb, evaporator fouling factor 0 m². k/W
- CA1 Cooling mode conditions: evaporator water inlet/outlet temperature 12 °C/7 °C, outdoor air temperature 35 °C, evaporator fouling factor 0 m². k/W
- η_{s heat 30/35°C} & SCOP_{30/35°C}**
SEER_{12/7°C} & SEPR_{12/7°C}
- Values in bold comply with Ecodesign Regulation (EU) No. 813/2013 for Heating applications**
- Applicable Ecodesign regulation (EU) No. 2016/2281
- (1) In dB ref=10⁻¹² W, 'A' weighted. Declared dual-number noise emission value in accordance with ISO 4871 with an uncertainty of +/-3 dB(A). Measured in accordance with ISO 9614-1 and certified by Eurovent. Cooling mode operation.
- (2) In dB ref 20 μPa, (A) weighting. Declared dual-number noise emission value in accordance with ISO 4871 with an uncertainty of +/-3 dB(A). For information, calculated from the sound power Lw(A).



Eurovent certified values

TECHNICAL SPECIFICATIONS - REVERSIBLE HEAT PUMP

AQUACIATPOWER ILD		0602R	0700R	0800R	0900R	1000R	1150R
Dimensions							
Standard unit							
Length	mm	2410	2410	2410	2410	2410	3604
Width	mm	2253	2253	2253	2253	2253	2253
Height	mm	2324	2324	2324	2324	2324	2324
Unit + water buffer tank module option⁽³⁾							
Length	mm	3604	3604	3604	3604	3604	4798
Operating weight ⁽³⁾							
Standard unit	kg	1569	1575	1784	1811	1817	2394
Unit + Ultra Low Noise option	kg	1672	1678	1918	1946	1952	2552
Unit + Ultra Low Noise + HP dual-pump hydraulic module option	kg	1808	1814	2065	2092	2098	2747
Unit + Ultra Low Noise + HP dual-pump hydraulic module + Water buffer tank module option	kg	2791	2797	3048	3075	3081	3756
Compressors		Hermetic Scroll 48.3 r/s					
Circuit A		1	1	2	2	2	2
Circuit B		2	2	2	2	2	3
Number of power stages		3	3	4	4	4	5
Unit PED category		III					
Refrigerant⁽³⁾		R-32 / A2L/ GWP= 675 in accordance with ARI4					
Circuit A	kg	10,5	10,5	16,0	16,0	16,0	16,0
	tCO ₂ e	7,1	7,1	10,8	10,8	10,8	10,8
Circuit B	kg	16,0	16,0	16,0	16,0	16,0	28,5
	tCO ₂ e	10,8	10,8	10,8	10,8	10,8	19,2
Oil							
Circuit A	l	6,6	6,6	13,2	13,2	13,2	13,2
Circuit B	l	13,2	13,2	13,2	13,2	13,2	19,8
Capacity control		Connect'Touch					
Minimum capacity	%	33	33	25	25	25	20
Condenser		Grooved copper tubes and aluminium fins					
Fans		Axial with rotating impeller					
Standard unit							
Quantity		3	3	4	4	4	5
Maximum total air flow	l/s	11790	11790	15720	15720	15720	19650
Maximum rotation speed	r/s	12	12	12	12	12	12
Maximum total air flow with high rated energy efficiency option	l/s	14460	14460	19280	19280	19280	24100
Maximum rotation speed with high rated energy efficiency option	r/s	16	16	16	16	16	16
Evaporator		Dual-circuit plate heat exchanger					
Water volume	l	16,2	16,2	16,2	20,7	20,7	38,7
Max. water-side operating pressure without hydraulic module	kPa	1000	1000	1000	1000	1000	1000
Hydraulic module (option)		Pump, Victaulic screen filter, relief valve, water and air vent valve, pressure sensors					
Pump		Centrifugal pump, monocell, 48.3 r/s, low- or high-pressure (as required), single or dual (as required)					
Expansion tank volume (Option)	l	50	50	50	50	50	80
Buffer tank volume (optional)	l	550	550	550	550	550	550
Max. water-side operating pressure with hydraulic module	kPa	400	400	400	400	400	400
Water connections with or without hydraulic module		Victaulic® type					
Connections	inches	3	3	3	3	3	4
External diameter	mm	88,5	88,6	88,7	88,8	88,9	114,3
Casing paint colour		Colour code RAL 7035 & 7024					

(3) Values are guidelines only. Refer to the unit name plate.



TECHNICAL SPECIFICATIONS - REVERSIBLE HEAT PUMP

AQUACIATPOWER ILD			1250R	1400R	1500R	1600R	1750R	2000R	
Heating									
Standard unit Full load performances*	HA1	Rated capacity	kW	336	387	406	441	467	537
		COP	kW/kW	3,81	3,82	3,81	3,80	3,73	3,80
	HA2	Rated capacity	kW	329	378	397	431	458	526
		COP	kW/kW	3,09	3,10	3,09	3,10	3,03	3,09
Energy efficiency efficiency**	HA1	SCOP _{30/35°C}	kWh/kWh	3,58	3,55	3,57	3,54	3,53	3,57
		ηs heat _{30/35°C}	%	140	139	140	139	138	140
		P _{rated}	kW	266	305	321	349	371	400
Unit + Rated & Seasonal high performance options Full load performances*	HA1	Rated capacity	kW	336	387	406	441	467	537
		COP	kW/kW	3,81	3,82	3,81	3,80	3,73	3,80
	HA1	SCOP _{30/35°C}	kWh/kWh	3,86	3,90	3,91	3,92	3,89	3,96
ηs heat _{30/35°C}		%	151	153	153	154	153	155	
P _{rated}		kW	265	305	320	348	370	400	
Cooling									
Standard unit Full load performances*	CA1	Rated capacity	kW	305	341	358	389	414	470
		EER		2,59	2,64	2,57	2,64	2,55	2,55
Energy efficiency efficiency**		SEER _{12/7°C} Comfort low temp.	kWh/kWh	4,50	4,46	4,33	4,44	4,38	4,32
		SEPR _{12/7°C} Process high temp.	kWh/kWh	4,76	4,93	4,79	4,94	4,82	4,83
Unit + Rated & Seasonal high performance options Full load performances*	CA1	Rated capacity	kW	324	362	381	413	439	500
		EER	kW/kW	2,80	2,82	2,76	2,81	2,74	2,73
Energy efficiency efficiency**		SEER _{12/7°C} Comfort low temp.	kWh/kWh	4,81	4,88	4,87	4,81	4,75	4,81
		SEPR _{12/7°C} Process high temp.	kWh/kWh	5,34	5,60	5,40	5,60	5,43	5,47
Sound levels									
Unit + High temperature option/Rated high performance									
Sound power ⁽¹⁾			dB(A)	93,5	94,0	94,0	94,5	94,5	95,0
Sound pressure at 10 m ⁽²⁾			dB(A)	61,5	62,0	62,0	62,0	62,0	62,5
Standard unit									
Sound power ⁽¹⁾			dB(A)	91,0	91,5	91,5	92,0	92,5	93,0
Sound pressure at 10 m ⁽²⁾			dB(A)	58,5	59,5	59,5	60,0	60,0	60,5
Unit + Very Low Noise option⁽³⁾									
Sound power ⁽¹⁾			dB(A)	88,0	89,0	89,0	89,5	90,0	90,0
Sound pressure at 10 m ⁽²⁾			dB(A)	55,5	56,5	56,5	57,0	57,5	57,5
Unit + Ultra Low Noise option⁽³⁾									
Sound power ⁽¹⁾			dB(A)	86,0	86,5	87,0	87,5	87,5	88,0
Sound pressure at 10 m ⁽²⁾			dB(A)	54,0	54,5	55,0	55,5	55,5	56,0

* In accordance with EN14511-3:2022.
 ** In accordance with EN14825:2022, average climate conditions
 HA1 Heating mode conditions: Water type heat exchanger water inlet/outlet temperature 30 °C/35 °C, outdoor air temperature tdb/twb = 7 °C db/6 °C wb, evaporator fouling factor 0 m². k/W
 HA2 Heating mode conditions: Water type heat exchanger water inlet/outlet temperature 40 °C/45 °C, outdoor air temperature tdb/twb = 7 °C db/6 °C wb, evaporator fouling factor 0 m². k/W
 CA1 Cooling mode conditions: evaporator water inlet/outlet temperature 12 °C/7 °C, outdoor air temperature 35 °C, evaporator fouling factor 0 m². k/W
ηs heat_{30/35°C} & **SCOP**_{30/35°C} **Values in bold comply with Ecodesign Regulation (EU) No. 813/2013 for Heating applications**
SEER_{12/7 °C} & **SEPR**_{12/7 °C} Applicable Ecodesign regulation (EU) No. 2016/2281
 (1) In dB ref=10⁻¹² W, 'A' weighted. Declared dual-number noise emission value in accordance with ISO 4871 with an uncertainty of +/-3 dB(A). Measured in accordance with ISO 9614-1 and certified by Eurovent. Cooling mode operation.
 (2) In dB ref 20 μPa, (A) weighting. Declared dual-number noise emission value in accordance with ISO 4871 with an uncertainty of +/-3 dB(A). For information, calculated from the sound power Lw(A).
 (3) In dB ref 20 μPa, (A) weighting. Declared dual-number noise emission value in accordance with ISO 4871 with an uncertainty of +/-3 dB(A). For information, calculated from the sound power Lw(A).



Eurovent certified values



TECHNICAL SPECIFICATIONS - REVERSIBLE HEAT PUMP

AQUACIATPOWER ILD		1250R	1400R	1500R	1600R	1750R	2000R	
Dimensions								
Standard unit								
Length	mm	3604	3604	3604	4798	4798	4798	
Width	mm	2253	2253	2253	2253	2253	2253	
Height	mm	2324	2324	2324	2324	2324	2324	
Unit + water buffer tank module option⁽³⁾		mm	4798	4798	4798	5992	5992	
Length	mm	4798	4798	4798	5992	5992	5992	
Operating weight ⁽³⁾								
Standard unit		kg	2452	2672	2678	3154	3180	3430
Unit + Ultra Low Noise option		kg	2611	2855	2861	3361	3387	3661
Unit + Ultra Low Noise + HP dual-pump hydraulic module option		kg	2806	3089	3095	3595	3658	3932
Unit + Ultra Low Noise + HP dual-pump hydraulic module + Water buffer tank module option		kg	3815	4098	4104	4595	4658	4932
Compressors								
Hermetic Scroll 48.3 r/s								
Circuit A/C			2	2	2	3	3	4
Circuit B/D			3	4	4	4	4	4
Number of power stages			5	6	6	7	7	8
Unit PED category			IV	IV	IV	IV	IV	IV
Refrigerant⁽³⁾								
R-32 / A2L/ GWP= 675 in accordance with ARI4								
Circuit A/C		kg	18,0	18,0	18,0	29,0	29,0	35,0
		tCO ₂ e	12,2	12,2	12,2	19,6	19,6	23,6
Circuit B/D		kg	28,5	34,0	34,0	34,5	35,0	35,0
		tCO ₂ e	19,2	23,0	23,0	23,3	23,6	23,6
Oil								
Circuit A/C		l	13,2	13,2	13,2	22,8	22,8	30,4
Circuit B/D		l	19,8	26,4	26,4	30,4	30,4	30,4
Capacity control								
Connect'Touch								
Minimum capacity		%	20	17	17	14	14	13
Condenser								
Grooved copper tubes and aluminium fins								
Fans								
Axial with rotating impeller								
Standard unit								
Quantity			5	6	6	7	7	8
Maximum total air flow		l/s	19650	23580	23580	27510	27510	31440
Maximum rotation speed		r/s	12	12	12	12	12	12
Maximum total air flow with high rated energy efficiency option		l/s	24100	28920	28920	33740	33740	38560
Maximum rotation speed with high rated energy efficiency option		r/s	16	16	16	16	16	16
Evaporator								
Dual-circuit plate heat exchanger								
Water volume		l	48,6	48,6	48,6	48,6	52,2	58,5
Max. water-side operating pressure without hydraulic module		kPa	1000	1000	1000	1000	1000	1000
Hydraulic module (option)								
Pump, Victaulic screen filter, relief valve, water and air vent valve, pressure sensors								
Centrifugal pump, monocell, 48.3 r/s, low- or high-pressure (as required), single or dual (as required)								
Expansion tank volume (Option)		l	80	80	80	80	80	80
Buffer tank volume (optional)		l	550	550	550	550	550	550
Max. water-side operating pressure with hydraulic module		kPa	400	400	400	400	400	400
Water connections with or without hydraulic module								
Victaulic® type								
Module 1/Module 2 connections ^(a)		inches	4	4	4	4	4	4
Module 1/Module 2 external diameter ^(a)		mm	114,4	114,5	114,6	114,7	114,8	114,9
Casing paint colour								
Colour code RAL 7035 & 7024								

(3) Values are guidelines only. Refer to the unit name plate.

(a) Modules 1 and 2 only relate to sizes 2300R to 4000R.



TECHNICAL SPECIFICATIONS - REVERSIBLE HEAT PUMP

AQUACIATPOWER ILD			2300R	2500R	2800R	3000R	3200R	3500R	4000R	
Heating										
Standard unit Full load performances*	HA1	Rated capacity	kW	635	673	774	812	883	935	1075
		COP	kW/kW	3,82	3,81	3,82	3,81	3,80	3,73	3,80
	HA2	Rated capacity	kW	620	658	757	795	863	915	1052
		COP	kW/kW	3,10	3,09	3,10	3,09	3,10	3,03	3,09
Energy efficiency efficiency**	HA1	SCOP_{30/35°C}	kWh/kWh	3,57	3,58	3,55	3,57	3,54	3,53	3,57
		ηs heat_{30/35°C}	%	140	140	139	140	139	138	140
		P _{rated}	kW	499	530	609	641	696	741	800
Unit + Rated & Seasonal high performance options Full load performances*	HA1	Rated capacity	kW	635	673	774	812	883	935	1075
		COP	kW/kW	3,82	3,81	3,82	3,81	3,80	3,73	3,80
Energy efficiency efficiency**	HA1	SCOP_{30/35°C}	kWh/kWh	3,87	3,86	3,90	3,91	3,92	3,89	3,96
		ηs heat_{30/35°C}	%	152	151	153	153	154	153	155
		P _{rated}	kW	499	530	609	641	696	741	800
Cooling										
Standard unit Full load performances*	CA1	Rated capacity	kW	569	610	682	716	778	827	941
		EER		2,67	2,60	2,64	2,57	2,65	2,56	2,55
Energy efficiency efficiency**		SEER _{12/7°C} Comfort low temp.	kWh/kWh	4,48	4,49	4,45	4,32	4,43	4,37	4,30
		SEPR _{12/7°C} Process high temp.	kWh/kWh	4,86	4,76	4,91	4,75	4,90	4,80	4,78
Unit + Rated & Seasonal high performance options Full load performances*	CA1	Rated capacity	kW	604	648	723	761	825	878	999
		EER	kW/kW	2,85	2,80	2,82	2,76	2,81	2,74	2,73
Energy efficiency efficiency**		SEER _{12/7°C} Comfort low temp.	kWh/kWh	4,77	4,81	4,88	4,87	4,81	4,75	4,81
		SEPR _{12/7°C} Process high temp.	kWh/kWh	5,49	5,34	5,60	5,40	5,60	5,43	5,47
Sound levels										
Unit + High temperature option/Rated high performance										
		Sound power ⁽¹⁾	dB(A)	96,0	96,5	97,0	97,0	97,5	97,5	98,0
		Sound pressure at 10 m ⁽²⁾	dB(A)	64,0	64,0	64,5	65,0	65,0	65,0	65,0
Standard unit										
		Sound power ⁽¹⁾	dB(A)	93,5	94,0	94,5	94,5	95,0	95,5	96,0
		Sound pressure at 10 m ⁽²⁾	dB(A)	61,0	61,5	62,5	62,5	63,0	63,0	63,5
Unit + Very Low Noise option⁽³⁾										
		Sound power ⁽¹⁾	dB(A)	91,0	91,0	92,0	92,0	92,5	93,0	93,0
		Sound pressure at 10 m ⁽²⁾	dB(A)	58,5	58,5	59,5	59,5	60,0	60,5	60,5
Unit + Ultra Low Noise option⁽³⁾										
		Sound power ⁽¹⁾	dB(A)	89,0	89,0	89,5	90,0	90,5	90,5	91,0
		Sound pressure at 10 m ⁽²⁾	dB(A)	57,0	57,0	57,5	58,0	58,5	58,5	59,0

* In accordance with EN14511-3:2022.
 ** In accordance with EN14825:2022, average climate conditions
 HA1 Heating mode conditions: Water type heat exchanger water inlet/outlet temperature 30 °C/35 °C, outdoor air temperature tdb/twb = 7 °C db/6 °C wb, evaporator fouling factor 0 m². k/W
 HA2 Heating mode conditions: Water type heat exchanger water inlet/outlet temperature 40 °C/45 °C, outdoor air temperature tdb/twb = 7 °C db/6 °C wb, evaporator fouling factor 0 m². k/W
 CA1 Cooling mode conditions: evaporator water inlet/outlet temperature 12 °C/7 °C, outdoor air temperature 35 °C, evaporator fouling factor 0 m². k/W
ηs heat_{30/35°C} & SCOP_{30/35°C} Values in bold comply with Ecodesign Regulation (EU) No. 813/2013 for Heating applications
SEER_{12/7°C} & SEPR_{12/7°C} Applicable Ecodesign regulation (EU) No. 2016/2281
 (1) In dB ref=10⁻¹² W, 'A' weighted. Declared dual-number noise emission value in accordance with ISO 4871 with an uncertainty of +/-3 dB(A). Measured in accordance with ISO 9614-1 and certified by Eurovent. Cooling mode operation.
 (2) In dB ref 20 μPa, (A) weighting. Declared dual-number noise emission value in accordance with ISO 4871 with an uncertainty of +/-3 dB(A). For information, calculated from the sound power Lw(A).
 (3) In dB ref 20 μPa, (A) weighting. Declared dual-number noise emission value in accordance with ISO 4871 with an uncertainty of +/-3 dB(A). For information, calculated from the sound power Lw(A).



Eurovent certified values

TECHNICAL SPECIFICATIONS - REVERSIBLE HEAT PUMP

AQUACIATPOWER ILD		2300R	2500R	2800R	3000R	3200R	3500R	4000R	
Dimensions									
Standard unit									
Length	mm	7708	7708	7708	7708	10096	10096	10096	
Width	mm	2253	2253	2253	2253	2253	2253	2253	
Height	mm	2324	2324	2324	2324	2324	2324	2324	
Unit + water buffer tank module option⁽³⁾		mm	5992	5992	5992	5992	5992	5992	
Length	mm	-	-	-	-	-	-	-	
Operating weight ⁽³⁾									
Standard unit		kg	4787	4905	5344	5356	6308	6360	6859
Unit + Ultra Low Noise option		kg	5104	5222	5710	5722	6722	6774	7322
Unit + Ultra Low Noise + HP dual-pump hydraulic module option		kg	5494	5611	6178	6190	7191	7317	7865
Unit + Ultra Low Noise + HP dual-pump hydraulic module + Water buffer tank module option		kg	-	-	-	-	-	-	-
Compressors									
Hermetic Scroll 48.3 r/s									
Circuit A/C			2/2	2/2	2/2	2/2	3/3	3/3	4/4
Circuit B/D			3/3	3/3	4/4	4/4	4/4	4/4	4/4
Number of power stages			10	10	12	12	14	14	16
Unit PED category			III	IV	IV	IV	IV	IV	IV
Refrigerant⁽³⁾									
R-32 / A2L/ GWP= 675 in accordance with ARI4									
Circuit A/C		kg	16,0 / 16,0	18,0 / 18,0	18,0 / 18,0	18,0 / 18,0	29,0 / 29,0	29,0 / 29,0	35,0 / 35,0
		tCO ₂ e	10,8 / 10,8	12,2 / 12,2	12,2 / 12,2	12,2 / 12,2	19,6 / 19,6	19,6 / 19,6	23,6 / 23,6
Circuit B/D		kg	28,5 / 28,5	28,5 / 28,5	34,0 / 34,0	34,0 / 34,0	34,5 / 34,5	35,0 / 35,0	35,0 / 35,0
		tCO ₂ e	19,2 / 19,2	19,2 / 19,2	23,0 / 23,0	23,0 / 23,0	23,3 / 23,3	23,6 / 23,6	23,6 / 23,6
Oil									
Circuit A/C		l	13,2 / 13,2	13,2 / 13,2	13,2 / 13,2	13,2 / 13,2	22,8 / 22,8	22,8 / 22,8	30,4 / 30,4
Circuit B/D		l	22,8 / 22,8	22,8 / 22,8	30,4 / 30,4	30,4 / 30,4	30,4 / 30,4	30,4 / 30,4	30,4 / 30,4
Capacity control									
Connect'Touch									
Minimum capacity		%	10	10	8	8	7	7	6
Condenser									
Grooved copper tubes and aluminium fins									
Fans									
Axial with rotating impeller									
Standard unit									
Quantity			10	10	12	12	14	14	16
Maximum total air flow		l/s	39300	39300	47160	47160	55020	55020	62880
Maximum rotation speed		r/s	12	12	12	12	12	12	12
Maximum total air flow with high rated energy efficiency option		l/s	48200	48200	57840	57840	67480	67480	77120
Maximum rotation speed with high rated energy efficiency option		r/s	16	16	16	16	16	16	16
Evaporator									
Dual-circuit plate heat exchanger									
Water volume		l	77,4	97,2	97,2	97,2	97,2	104,4	117
Max. water-side operating pressure without hydraulic module		kPa	1000	1000	1000	1000	1000	1000	1000
Hydraulic module (option)									
Pump, Victaulic screen filter, relief valve, water and air vent valve, pressure sensors									
Pump			Centrifugal pump, monocell, 48.3 r/s, low- or high-pressure (as required), single or dual (as required)						
Expansion tank volume (Option)		l	-	-	-	-	-	-	-
Buffer tank volume (optional)		l	-	-	-	-	-	-	-
Max. water-side operating pressure with hydraulic module		kPa	400	400	400	400	400	400	400
Water connections with or without hydraulic module									
Victaulic® type									
Module 1/Module 2 connections ^(a)		inches	4 / 4	4 / 4	4 / 4	4 / 4	4 / 4	4 / 4	4 / 4
Module 1/Module 2 external diameter ^(a)		mm	114,3 / 114,3	114,3 / 114,3	114,3 / 114,3	114,3 / 114,3	114,3 / 114,3	114,3 / 114,3	114,3 / 114,3
Casing paint colour									
Colour code RAL 7035 & 7024									

(3) Values are guidelines only. Refer to the unit name plate.

(a) Modules 1 and 2 only relate to sizes 2300R to 4000R.

ELECTRICAL SPECIFICATIONS

■ Basic unit (excluding pump)

AQUACIATPOWER LD		0602R	0650R	0750R	0900R	1100R	1200R	1350R	1400R	1600R	1750R
Power circuit supply											
Rated voltage	V-ph-Hz	400-3-50									
Voltage range	V	360-440									
Control circuit supply											
24 V via internal transformer											
Maximum operating input power^{(1) or (2)}											
Circuit A&B	kW	71,6	77,2	86,8	95,4	114,6	128,9	143,3	157,5	171,9	186,2
Power factor at maximum power^{(1) or (2)}											
Displacement Power Factor (Cos Phi), standard unit		0,83	0,83	0,83	0,83	0,83	0,83	0,83	0,83	0,83	0,83
Maximum operating current draw (Un)^{(1) or (2)}											
Standard unit	A	123,9	134,4	151,0	165,2	198,4	223,1	248,0	272,7	297,6	322,3
Maximum current (Un-10%)^{(1) or (2)}											
Standard unit	A	132,6	143,8	161,8	176,8	212,8	239	266	292,2	319,2	345,4
Maximum start-up current (Un)^{(2) + (3)}											
Standard unit	A	300	347	364	341	411	436	461	485	510	535
Unit + Electronic soft starter option	A	257	295	312	298	359	384	409	433	458	483

AQUACIATPOWER LD		1800R	2000R	2200R	2400R	2650R	2800R	2950R	3200R	3500R
Power circuit supply										
Rated voltage	V-ph-Hz	400-3-50								
Voltage range	V	360-440								
Control circuit supply										
24 V via internal transformer										
Maximum operating input power^{(1) or (2)}										
Circuit A&B	kW	200,6	229,2	246,7	271,9	295,3	316,7	328,4	361,4	392,6
Power factor at maximum power^{(1) or (2)}										
Displacement Power Factor (Cos Phi), standard unit		0,83	0,83	0,83	0,83	0,83	0,83	0,83	0,83	0,83
Maximum operating current draw (Un)^{(1) or (2)}										
Standard unit	A	347,2	396,8	432,3	478,0	517,0	556,2	575,7	634,4	686,4
Maximum current (Un-10%)^{(1) or (2)}										
Standard unit	A	372,4	425,6	464,8	514	556	598,2	619,2	682,4	738,4
Maximum start-up current (Un)^{(2) + (3)}										
Standard unit	A	560	609	763	815	848	893	906	971	1017
Unit + Electronic soft starter option	A	508	557	680	732	765	811	824	889	934

(1) Values at the unit's permanent maximum operating condition (as shown on the unit's nameplate).

(2) Values at the unit's maximum operating condition (as shown on the unit's nameplate).

(3) Maximum operating current of the smallest compressor(s) + fan current + locked rotor current of the largest compressor.

ELECTRICAL SPECIFICATIONS

AQUACIAT ^{POWER} ILD		0602R	0700R	0800R	0900R	1000R	1150R	1250R	1400R	1500R	1600R
Power circuit supply											
Rated voltage	V-ph-Hz	400-3-50									
Voltage range	V	360-440									
Control circuit supply											
24 V via internal transformer											
Maximum operating input power^{(1) or (2)}											
Circuit A&B (Module 1/Module 2) ^(a)	kW	71,6	81,2	95,4	105,0	114,6	133,7	143,3	162,3	171,9	186,2
Power factor at maximum power^{(1) or (2)}											
Displacement Power Factor (Cos Phi), standard unit		0,83	0,83	0,83	0,83	0,83	0,83	0,83	0,83	0,83	0,83
Maximum operating current draw (Un)^{(1) or (2)}											
Standard unit (Module 1/Module 2) ^(a)	A	123,9	140,5	165,2	181,8	198,4	231,4	248,0	281,0	297,6	322,3
Maximum current (Un-10%)^{(1) or (2)}											
Standard unit (Module 1/Module 2) ^(a)	A	135,6	151,6	180,8	196,8	212,8	250,0	266,0	303,2	319,2	348,4
Maximum start-up current (Un) ^{(2) + (3)}											
Standard unit (Module 1/Module 2) ^(a)	A	299,8	355,3	341,1	394,4	411	444	460,6	493,6	510,2	534,9
Unit + Electronic soft starter option (Module 1/Module 2) ^(a)	A	256,8	303	298	342	359	392	409	442	458	483

AQUACIAT ^{POWER} ILD		1750R	2000R	2300R	2500R	2800R	3000R	3200R	3500R	4000R
Power circuit supply										
Rated voltage	V-ph-Hz	400-3-50								
Voltage range	V	360-440								
Control circuit supply										
24 V via internal transformer										
Maximum operating input power^{(1) or (2)}										
Circuit A&B (Module 1/Module 2) ^(a)	kW	200,6	229,2	139,2 / 139,2	148,7 / 148,7	169,0 / 169,0	178,6 / 178,6	193,7 / 193,7	208,1 / 208,1	237,8 / 237,8
Power factor at maximum power^{(1) or (2)}										
Displacement Power Factor (Cos Phi), standard unit		0,83	0,83	0,85	0,85	0,85	0,85	0,85	0,85	0,85
Maximum operating current draw (Un)^{(1) or (2)}										
Standard unit (Module 1/Module 2) ^(a)	A	347,2	396,8	235,4 / 235,4	252 / 252	285,8 / 285,8	302,4 / 302,4	327,9 / 327,9	352,8 / 352,8	403,2 / 403,2
Maximum current (Un-10%)^{(1) or (2)}										
Standard unit (Module 1/Module 2) ^(a)	A	372,4	425,6	254 / 254	270 / 270	308 / 308	324 / 324	354 / 354	378 / 378	432 / 432
Maximum start-up current (Un) ^{(2) + (3)}										
Standard unit (Module 1/Module 2) ^(a)	A	559,8	609,4	448 / 448	465 / 465	498 / 498	515 / 515	541 / 541	565 / 565	616 / 616
Unit + Soft Starter option (Module 1/Module 2) ^(a)	A	508	557	396 / 396	413 / 413	446 / 446	463 / 463	489 / 489	513 / 513	564 / 564

(1) Values at the unit's permanent maximum operating condition (as shown on the unit's nameplate).

(2) Values at the unit's maximum operating condition (as shown on the unit's nameplate).

(3) Maximum operating current of the smallest compressor(s) + fan current + locked rotor current of the largest compressor.

(a) Modules 1 and 2 only relate to sizes 2300R to 4000R.

ELECTRICAL SPECIFICATIONS

■ Short circuit current withstand capability (TN system⁽¹⁾)

AQUACIAT ^{POWER} LD	0602R	0650R	0750R	0900R	1100R	1200R	1350R	1400R	1600R
Rated short-circuit withstand currents									
Rated short time (1s) current - I _{cw} kA eff	8,5	8,5	8,5	8,5	8,5	20	20	20	20
Rated peak current - I _{pk} kA pk	330	330	330	330	330	330	330	330	330
Value with upstream protection ⁽¹⁾									
Rated conditional short circuit current I _{cc} kA eff	50	50	50	50	50	50	50	50	50
Associated protection - type	INS250	INS250	INS250	INS250	INS250	INS400	INS400	INS400	INS400
Associated protection - rating/reference	TM160D / LV430840	TM200D / LV431831	TM200D / LV431831	TM250D / LV431831	TM250D / LV431831	TM250D / LV431831	Micrologic 2.3 400 A / LV432693	Micrologic 2.3 400 A / LV432693	Micrologic 2.3 400 A / LV432693

AQUACIAT ^{POWER} LD	1750R	1800R	2000R	2200R	2400R	2650R	2800R	2950R	3200R	3500R
Rated short-circuit withstand currents										
Rated short time (1s) current - I _{cw} kA eff	20	20	20	20	20	20	35	35	35	35
Rated peak current - I _{pk} kA pk	330	330	330	330	330	330	330	330	330	330
Value with upstream protection ⁽¹⁾										
Rated conditional short circuit current I _{cc} kA eff	50	50	50	50	50	50	50	50	50	50
Associated protection - type	INS400	INS500	INS500	INS630	INS630	INS630	INS800	INS800	INS800	INS800
Associated protection - rating/reference	Micrologic 2.3 400 A / LV432693	Micrologic 2.3 630 A / LV432893	Micrologic 2.3 630 A / LV432893	Micrologic 2.3 630 A / LV432893	Micrologic 2.3 630 A / LV432893	Micrologic 2.3 630 A / LV432893	Micrologic 5.0 800 A / /34426	Micrologic 5.0 800 A / /34426	Micrologic 5.0 800 A / /34426	Micrologic 5.0 800 A / /34426

(1) If another current limitation protection device is used, its time-current and thermal constraint (I²t) trip characteristics must be at least equivalent to those of the recommended protection.

Note: The short-circuit withstand current capability values above have been established for the TN system.

ELECTRICAL SPECIFICATIONS

■ Short circuit current withstand capability (TN system⁽¹⁾)

AQUACIAT ^{POWER} ILD	0602R	0700R	0800R	0900R	1000R	1150R	1250R	1400R	1500R	1600R	
Rated short-circuit withstand currents											
Rated short time (1s) current - I _{cw} (Module 1 / Module 2) ^(a) kA eff	8,5	8,5	8,5	8,5	8,5	20	20	20	20	20	
Allowable rated peak current - I _{pk} (Module 1 / Module 2) ^(a) kA pk	330	330	330	330	330	330	330	330	330	330	
Value with upstream protection ⁽¹⁾											
Rated conditional short circuit current I _{cc} (Module 1 / Module 2) ^(a) kA eff	50	50	50	50	50	50	50	50	50	50	
Associated protection - type (Module 1/Module 2) ^(a)	INS250	INS250	INS250	INS250	INS250	INS400	INS400	INS400	INS400	INS400	
Associated protection (rating/ reference)	Module 1 ^(a)	TM160D / LV430840	TM200D / LV431831	TM250D / LV431831	TM250D / LV431831	TM250D / LV431831	Micrologic 2.3 400 A / LV432693	Micrologic 2.3 400 A / LV432693	Micrologic 2.3 400 A / LV432693	Micrologic 2.3 400 A / LV432693	Micrologic 2.3 400 A / LV432693
	Module 2 ^(a)	-	-	-	-	-	-	-	-	-	

AQUACIAT ^{POWER} ILD	1750R	2000R	2300R	2500R	2800R	3000R	3200R	3500R	4000R	
Rated short-circuit withstand currents										
Rated short time (1s) current - I _{cw} (Module 1 / Module 2) ^(a) kA eff	20	20	20 / 20	20 / 20	20 / 20	20 / 20	20 / 20	20 / 20	20 / 20	
Allowable rated peak current - I _{pk} (Module 1 / Module 2) ^(a) kA pk	330	330	330 / 330	330 / 330	330 / 330	330 / 330	330 / 330	330 / 330	330 / 330	
Value with upstream protection ⁽¹⁾										
Rated conditional short circuit current I _{cc} (Module 1 / Module 2) ^(a) kA eff	50	50	50 / 50	50 / 50	50 / 50	50 / 50	50 / 50	50 / 50	50 / 50	
Associated protection - type (Module 1/Module 2) ^(a)	INS500	INS500	INS400 / INS400	INS400 / INS400	INS400 / INS400	INS400 / INS400	INS400 / INS400	INS500 / INS500	INS500 / INS500	
Associated protection (rating/ reference)	Module 1 ^(a)	Micrologic 2.3 630 A / LV432893	Micrologic 2.3 630 A / LV432893	Micrologic 2.3 400 A / LV432693	Micrologic 2.3 400 A / LV432693	Micrologic 2.3 400 A / LV432693	Micrologic 2.3 400 A / LV432693	Micrologic 2.3 400 A / LV432693	Micrologic 2.3 630 A / LV432893	Micrologic 2.3 630 A / LV432893
	Module 2 ^(a)	-	-	Micrologic 2.3 400 A / LV432693	Micrologic 2.3 400 A / LV432693	Micrologic 2.3 400 A / LV432693	Micrologic 2.3 400 A / LV432693	Micrologic 2.3 400 A / LV432693	Micrologic 2.3 630 A / LV432893	Micrologic 2.3 630 A / LV432893

(1) If another current limitation protection device is used, its time-current and thermal constraint (I²t) trip characteristics must be at least equivalent to those of the recommended protection.

(a) Modules 1 and 2 only relate to sizes 2300R to 4000R.

Note: The short-circuit withstand current capability values above have been established for the TN system.



PARTIAL RECOVERY WITH DESUPERHEATER

The **AQUACIAT^{POWER}** range may be equipped as an option with an energy recovery function using a desuperheater.

Heat from gases released by the compressors is recovered directly by a type of heat exchanger called a desuperheater located on the unit to produce free, additional hot water.

This optional configuration requires assembly in our factories and is by order only.

■ Refrigeration circuit diagram

This refrigeration diagram illustrates a unit with a desuperheater on each refrigerating circuit. For heat recovery to be possible, the unit must be operating. For the same cooling capacity, the desuperheater provides a source of free hot water and lowers the unit's electrical power consumption.

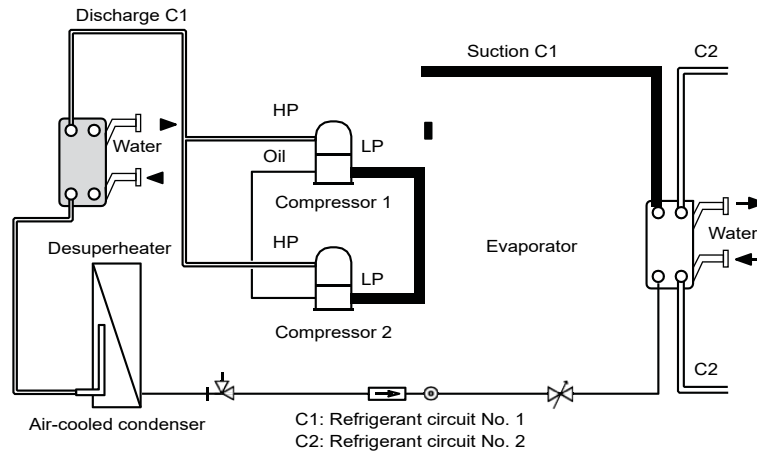

■ Hydraulic connections: configuration and precautions

The hydraulic supply for each desuperheater is delivered in parallel. In order to ensure that the unit can start and operate under the correct conditions, the desuperheater circuit water loop must be as short as possible and be able to increase quickly in temperature. The minimum desuperheater water inlet temperature is 30 °C. It may require the use of a three-way valve with its controller and a sensor controlling the minimum water inlet temperature.

Note: The water loop for the desuperheater circuit must include an expansion tank and a valve. Special attention should be paid when selecting the expansion tank as the recovery water circuit can reach 120°C if the pump is turned off or if no hot water is consumed

■ Operating limits

LD units

Desuperheater		Minimum	Maximum
Water inlet temperature at start-up	°C	30 (1)	75
Water outlet temperature during operation	°C	45	80
Water inlet temperature on shut-down	°C	3	75

ILD units

Desuperheater		Minimum	Maximum
Water inlet temperature at start-up	°C	30 (1)	60
Water outlet temperature during operation	°C	45	80
Water inlet temperature on shut-down	°C	3	60

Note: Do not exceed the maximum operating temperature.

(1) On start-up, the water inlet temperature must not be below 25 °C. On lower temperature installations, a 3-way valve is required until the desuperheater water outlet reaches 45 °C.



PARTIAL RECOVERY WITH DESUPERHEATER

Cooling mode operating range

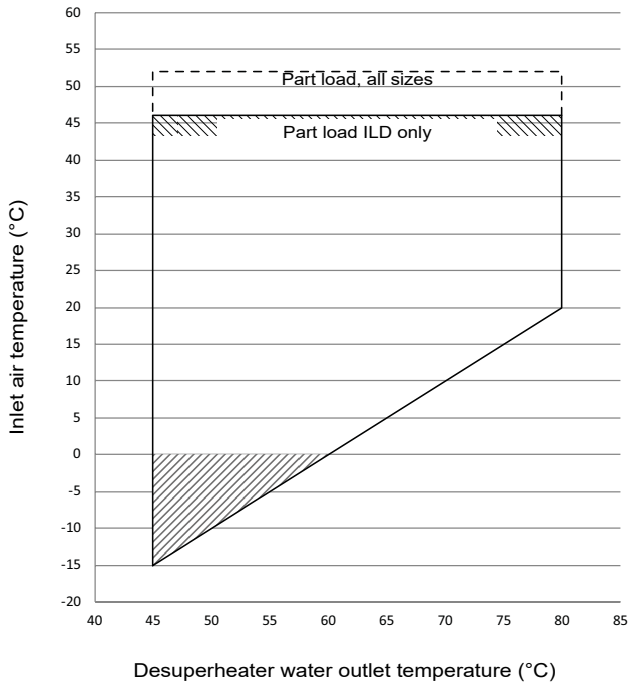

Heating mode operating range

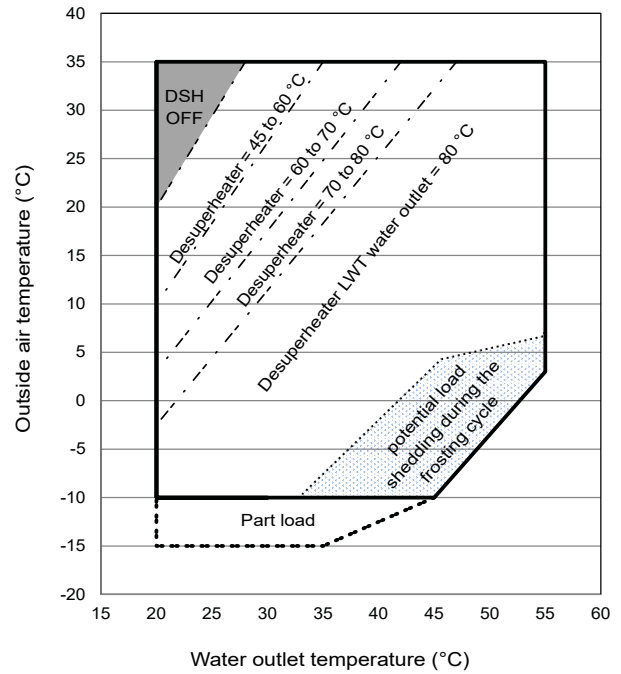

Notes

1. Desuperheater water type heat exchanger $\Delta T = 10K$.
2. The water type heat exchanger is protected against frost down to -20 °C (with Water exchanger frost protection option or water type heat exchanger and hydraulic module frost protection option (if present) or water loop protected by antifreeze solution for outdoor temperatures $< 0\text{ °C}$)
The water loop on the desuperheater water type heat exchanger must be protected by the customer for outdoor temperatures below 0 °C
3. These ranges are guidelines only. Verify the operating range with the electronic catalogue.

Key

- Operating range at full load
- Extension of the operating range, LD 602 to 1400 unit: frost protection required (see note 2).
- Heating mode: Part load at inlet air temperature between -10 and -15 °C .
Cooling mode: Part load above 46 °C of inlet air temperature.
- Limited desuperheater power.
- operating range at part load for ILD only with limited desuperheater power.
- Potential load shedding during the defrosting cycle at low outdoor temperatures (see operating range for ILD 602R - 2000R)
- Limited desuperheater power. Please refer to the selection in the electronic catalogue.
- Desuperheater not operational
- Limited desuperheater water outlet temperature



PARTIAL RECOVERY WITH DESUPERHEATER

■ Technical specifications

AQUACIATPOWER LD		0602R	0650R	0750R	0900R	1100R	1200R	1350R	1400R	1600R	1750R
Desuperheater in circuits A/B		Brazed-plate heat exchanger									
Water volume circuits A/B	l	2 / 3,75	2 / 3,75	3,75 / 3,75	3,75 / 3,75	3,75 / 3,75	3,75 / 5,5	3,75 / 5,5	5,5 / 5,5	5,5 / 5,5	5,5 / 7,5
Maximum operating pressure, water side	kPa	1000	1000	1000	1000	1000	1000	1000	1000	1000	1000
Hydraulic connections		Victaulic									
Connection	in	2"	2"	2"	2"	2"	2"	2"	2"	2"	2"
External diameter	mm	60,3	60,3	60,3	60,3	60,3	60,3	60,3	60,3	60,3	60,3
Operating weight ⁽¹⁾											
Standard unit + desuperheater option	kg	1409	1457	1457	1581	1616	2055	2109	2271	2329	2757
Unit + Ultra Low Noise + desuperheater option	kg	1492	1540	1540	1690	1725	2182	2236	2416	2474	2920
Unit + Ultra Low Noise + HP dual-pump hydraulic module + desuperheater option	kg	1627	1675	1675	1825	1871	2331	2431	2611	2669	3154
Unit + Ultra Low Noise + HP dual-pump hydraulic module + Water buffer tank module + desuperheater option	kg	2610	2658	2658	2808	2854	3318	3417	3597	3654	4146

AQUACIATPOWER LD		1800R	2000R	2200R	2400R	2650R	2800R	2950R	3200R	3500R
Desuperheater in circuits A/B		Brazed-plate heat exchanger								
Water volume circuits A/B	l	5,5 / 7,5	7,5 / 7,5	7,5 / 11	11 / 11	11 / 11	11 / 15	11 / 15	15 / 15	15 / 15
Maximum operating pressure, water side	kPa	1000	1000	1000	1000	1000	1000	1000	1000	1000
Hydraulic connections		Victaulic								
Connection	in	2"	2"	2"	2"	2"	2"	2"	2"	2"
External diameter	mm	60,3	60,3	60,3	60,3	60,3	60,3	60,3	60,3	60,3
Operating weight ⁽¹⁾										
Standard unit + desuperheater option	kg	2782	2987	3325	3571	3571	4102	4102	4351	4351
Unit + Ultra Low Noise + desuperheater option	kg	2945	3168	3458	3724	3724	4276	4276	4545	4545
Unit + Ultra Low Noise + HP dual-pump hydraulic module + desuperheater option	kg	3179	3439	3768	4034	4034	4665	4665	4934	4934
Unit + Ultra Low Noise + HP dual-pump hydraulic module + Water buffer tank module + desuperheater option	kg	4171	4431	4775	5041	5041	5686	5686	5955	5955

(1) Weights are guidelines only. Refer to the unit name plate.



PARTIAL RECOVERY WITH DESUPERHEATER

■ Technical specifications

AQUACIATPOWER ILD		0602R	0700R	0800R	0900R	1000R	1150R	1250R	1400R	1500R	1600R
Desuperheater on circuits A and C / B and D ^(a)		Brazed-plate heat exchanger									
Water volume of circuits A and C / B and D ^(a)	l	2 / 3,75	2 / 3,75	3,75 / 3,75	3,75 / 3,75	3,75 / 3,75	3,75 / 5,5	3,75 / 5,5	3,75 / 7,5	3,75 / 7,5	5,5 / 7,5
Maximum operating pressure, water side	kPa	1000	1000	1000	1000	1000	1000	1000	1000	1000	1000
Hydraulic connections		Victaulic									
Connection	in	2"	2"	2"	2"	2"	2"	2"	2"	2"	2"
External diameter	mm	60,3	60,3	60,3	60,3	60,3	60,3	60,3	60,3	60,3	60,3
Operating weight ⁽¹⁾											
Standard unit + desuperheater option	kg	1651	1657	1873	1900	1906	2500	2558	2785	2791	3283
Unit + Ultra Low Noise + desuperheater option	kg	1735	1741	1981	2009	2015	2626	2685	2930	2936	3446
Unit + Ultra Low Noise + HP dual-pump hydraulic module + desuperheater option	kg	1870	1876	2128	2156	2162	2821	2880	3164	3170	3681
Unit + Ultra Low Noise + HP dual-pump hydraulic module + Water buffer tank module + desuperheater option	kg	2853	2859	3111	3138	3144	3831	3889	4173	4179	4680

AQUACIATPOWER ILD		1750R	2000R	2300R	2500R	2800R	3000R	3200R	3500R	4000R
Desuperheater on circuits A and C / B and D ^(a)		Brazed-plate heat exchanger								
Water volume of circuits A and C / B and D ^(a)	l	5,5 / 7,5	7,5 / 7,5	3,75 / 5,5	3,75 / 5,5	3,75 / 7,5	3,75 / 7,5	5,5 / 7,5	5,5 / 7,5	7,5 / 7,5
Maximum operating pressure, water side	kPa	1000	1000	1000	1000	1000	1000	1000	1000	1000
Hydraulic connections		Victaulic								
Connection	in	2"	2"	2"	2"	2"	2"	2"	2"	2"
External diameter	mm	60,3	60,3	60,3	60,3	60,3	60,3	60,3	60,3	60,3
Operating weight ⁽¹⁾										
Standard unit + desuperheater option	kg	3309	3565	4999	5117	5570	5582	6567	6619	7130
Unit + Ultra Low Noise + desuperheater option	kg	3472	3746	5253	5370	5860	5872	6893	6945	7493
Unit + Ultra Low Noise + HP dual-pump hydraulic module + desuperheater option	kg	3744	4018	5642	5760	6328	6340	7361	7487	8035
Unit + Ultra Low Noise + HP dual-pump hydraulic module + Water buffer tank module + desuperheater option	kg	4743	5017	-	-	-	-	-	-	-

(1) Values are guidelines only. Refer to the unit name plate.

(a) Circuits C and D only relate to sizes 2300R to 4000R. These sizes are composed of 2 modules.



TOTAL HEAT RECOVERY

The **AQUACIAT^{POWER}** range can be equipped with a total heat recovery function as an option

The principle consists of producing free additional hot water at a high temperature of up to 65°C by adding a dual-circuit water-cooled condenser which allows all the heat released by the machine to be recovered.

This optional configuration requires assembly in our factories and is by order only.

Operating principle

If hot water production is required, the compressor discharge gases are directed towards the heat recovery condenser. The refrigerant releases its heat to the hot water that leaves the condenser at a temperature of up to 65°C. In this way, 100% of the heat rejected by the liquid chiller can be used to produce hot water. When the demand for heat is satisfied, the hot gas is again directed towards the air condenser where the heat is rejected to the outside air by the fans.

The hot water temperature is controlled by the machine's Connect Touch control unit.

Note: Heat recovery is only possible if the machine produces cold water at the same time.

■ Operating limits

LD units

Total recovery exchanger		Min.	Max.
Water inlet temperature at start-up	°C	25 ⁽¹⁾	60
Water outlet temperature during operation	°C	30	65
Water inlet temperature on shut-down	°C	3	70

Note: Do not exceed the maximum operating temperature.

(1) On start-up, the water inlet temperature must not be below 25 °C. For installations with a lower temperature, a three-way valve is necessary.

Operating range in cooling mode

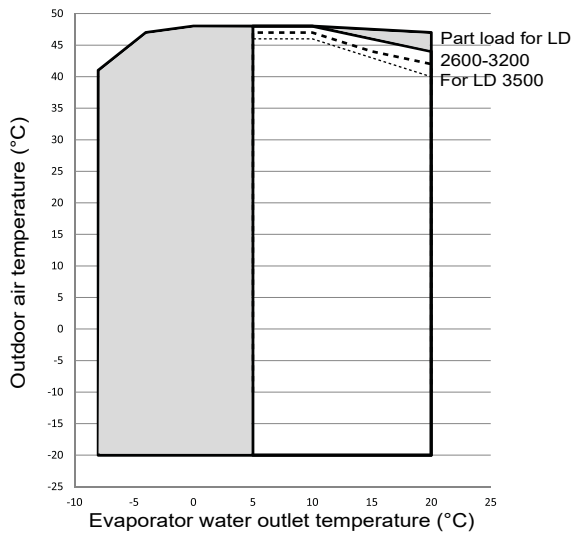

Key

- Full load
- Low temperature brine solution option
- Part load for LD 2600-3200
- Part load for LD 3500

Notes

1. Evaporator $\Delta T = 5K$
2. The unit must be either equipped with frost protection options for the water type heat exchangers (evaporator and heat recovery) and the hydraulic module (if used), or the water loop must be protected against freezing by the installer with an antifreeze solution
3. These ranges are guidelines only. Verify the operating range with the electronic catalogue.

Operating range in heat recovery mode

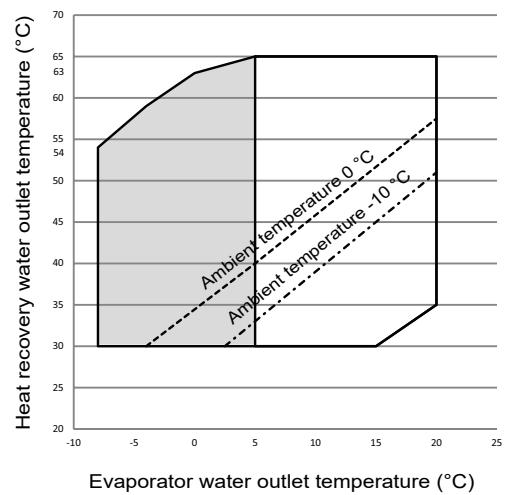

Key

- Full load
- Low temperature brine solution option
- Limitation to a part load of 50% below an ambient air temperature of -10 °C
- Limitation to a part load of 50% below an ambient air temperature of 0 °C

Notes

- Evaporator $\Delta T = 5K$
- Condenser $\Delta T = 5K$ up to 30RBP550 and 8K for sizes 610R to 950R
- These ranges are guidelines only. Verify the operating range with the electronic catalogue.



TOTAL HEAT RECOVERY

■ Technical specifications

AQUACIATPOWER LD	0602R	0650R	0750R	0900R	1100R	1200R	1350R	1400R	1600R	1750R
Total recovery exchanger	Brazed-plate heat exchanger									
Water volume circuits A/B	l	20	24	24	29	29	31	31	31	44
Maximum operating pressure, water side	kPa	600	600	600	600	600	600	600	600	600
Hydraulic connections	Victaulic									
Connection	in	3"	3"	3"	3"	3"	4"	4"	4"	4"
External diameter	mm	88,9	88,9	88,9	88,9	88,9	114,3	114,3	114,3	114,3
Operating weight ⁽¹⁾										
Standard unit + total recovery	kg	1490	1580	1580	1740	1775	2300	2354	4561	3084
Unit + Ultra Low Noise + total recovery option	kg	1573	1663	1663	1849	1884	2427	2481	4706	3247

AQUACIATPOWER LD	1800R	2000R	2200R	2400R	2650R	2800R	2950R	3200R	3500R
Total recovery exchanger	Brazed-plate heat exchanger								
Water volume circuits A/B	l	44	44	61	61	61	61	61	61
Maximum operating pressure, water side	kPa	600	600	600	600	600	600	600	600
Hydraulic connections	Victaulic								
Connection	in	4"	4"	5"	5"	5"	5"	5"	5"
External diameter	mm	114,3	114,3	139,7	139,7	139,7	139,7	139,7	139,7
Operating weight ⁽¹⁾									
Standard unit + total recovery	kg	3110	3315	3848	4093	4093	4627	4627	4876
Unit + Ultra Low Noise + total recovery option	kg	3273	3496	3981	4246	4246	4801	4801	5070

(1) Weights are guidelines only. Refer to the unit name plate.



FREE COOLING SYSTEM

Reducing operating costs and protecting the environment have become the key concerns, both for air conditioning applications, and for industrial processes and cooling data centres.

The free cooling option allows significant energy savings to be made in all applications that require cooling throughout the year, particularly when used in colder climates. In these regions, free cooling can be used to fulfil a large proportion of the cooling requirements both economically and in a way that respects the environment

In free cooling mode, the compressors are stopped, and only the fans are in operation. The Connect Touch control automatically switches from compressor cooling mode to free cooling mode depending on the cooler heat load and the temperature differential between the chilled water outlet and the ambient air.

Important: to optimise cooler performance, you are recommended to use the leaving water temperature setpoint offset function.

Operating principle

The unit's Connect Touch control maximises the use of the free cooling based on the needs of the application and the climate conditions. Once the chilled water/ambient air temperature differential exceeds the threshold value by 1K (2K on the Glycol Free version), the Connect Touch control activates Free Cooling and adjusts the air flow rate to optimise the unit's energy performance. If the operating conditions permit the free cooling to operate on its own to meet the requirements, the compressors are stopped. Two motorised valves direct the chilled water to the free cooling coils.

Three operating modes are possible:

Summer (warm weather season): Mechanical cooling mode

The liquid chiller meets the needs traditionally using the refrigerant circuit. The fluid bypasses the free cooling coils and is cooled by the evaporator.

Mid-season: Combination mode

It is possible to operate in combination Free Cooling and mechanical cooling mode. This helps optimise Free Cooling operations while covering the system's cooling requirements. The fluid is pre-cooled by the free cooling coils positioned in series with the refrigerant circuit evaporator which finalises cooling of the fluid.

Winter (cold weather season): Free cooling mode

Depending on the capacity requested and the setpoint, all of the requirements may be fulfilled by the Free Cooling in this operating mode without the fans running, thereby ensuring optimum energy efficiency.

Adaptations to requirements

The **AQUACIAT^{POWER}** LD Free Cooling is available with different performance levels depending on the user's needs:

- Total hydraulic free cooling on the 2 circuits, specifically designed for installations which have major cooling requirements all year round (industrial processes, data centres)
- Total hydraulic free cooling, Glycol Free version, enables the use of pure water in the cooling circuit.
- Partial hydraulic free cooling on 1 circuit, designed for installations which have limited cooling requirements during the winter (offices, hospitals, etc.)

Advantages of the built-in free cooling system

- The free cooling function is independent of the refrigerant circuit, which increases reliability and facilitates maintenance compared to free cooling built into the refrigerant circuit (DX FC).
- The Hydraulic Free Cooling design is intended to expand the scope of application compared to the Free Cooling refrigerant concept (DX FC) by enabling Free Cooling mode to be activated by a higher outdoor temperature, thereby allowing for greater energy savings.
- The built-in Hydraulic Free Cooling version developed based on the **AQUACIAT^{POWER}** range offers all of the advantages of a Free Cooling solution combined with the compact design of the base units.

Advantage of the Free Cooling Glycol Free system

- In applications or countries in which the use of glycol is strictly regulated or banned, the Free Cooling Glycol Free option is equipped with a separation heat exchanger, and only the circuit inside the unit contains glycol, while the user circuit contains pure water.
- This solution with an intermediate exchanger shifts the Free Cooling mode activation thresholds by a few degrees, and the heat exchangers selected by CIAT help to minimise this shift.



FREE COOLING SYSTEM

Physical characteristics of AQUACIATPOWER LD units with Free Cooling option

AQUACIATPOWER LD			0602R	0650R	0750R	0900R	1100R	1200R	1350R	1400R	1600R	
Cooling												
Unit + High energy efficiency option Full load performances*	CA1	Maximum rated capacity	kW	181	198	220	239	288	328	366	401	440
		EER	kW/kW	3,28	3,46	3,31	3,25	3,12	3,23	3,16	3,21	3,16
FREE COOLING												
Total free cooling option	CFC1	Maximum rated capacity	kW	182	243	243	243	243	303	303	364	364
		Free cooling EER	kW/kW	25,9	25,4	25,4	25,4	25,8	25,8	25,9	25,6	25,7
		Rate of coverage by free cooling	%	101%	122%	110%	102%	84%	93%	83%	91%	83%
		Outdoor temperature for 100% coverage by free cooling	°C	0,1	2,3	1,2	0,2	-2,3	-1,0	-2,6	-1,3	-2,6
		Pressure drops	kPa	94	112	112	112	102	107	101	117	112
		Sound power ⁽¹⁾	dB(A)	88,0	89,0	89,0	89,0	89,0	90,0	90,0	90,5	91,0
		Sound pressure at 10 m ⁽²⁾	dB(A)	69,0	70,5	70,5	70,5	70,5	70,5	70,5	71,0	71,5
Partial free cooling option	CFC1	Maximum rated capacity	kW	121	121	121	121	121	121	121	145	145
		Free cooling EER	kW/kW	25,8	25,8	25,8	25,8	25,9	26,0	26,0	19,2	19,1
		Rate of coverage by free cooling	%	67%	61%	55%	51%	42%	37%	33%	36%	33%
		Pressure drops	kPa	80	80	80	80	77	75	74	81	79
		Sound power ⁽¹⁾	dB(A)	86,0	86,0	86,0	86,0	86,0	86,0	86,0	87,5	88,0
		Sound pressure at 10 m ⁽²⁾	dB(A)	67,5	67,5	67,5	67,5	67,5	66,5	66,5	68,0	68,5
Unit + ultra low noise level option Full load performances*	CA1	Maximum rated capacity	kW	171	189	208	226	270	309	343	377	413
		EER	kW/kW	3,06	3,29	3,08	3,03	2,82	2,96	2,85	2,94	2,86
FREE COOLING												
Total free cooling option	CFC1	Maximum rated capacity	kW	148	197	197	197	197	247	247	296	296
		Free cooling EER	kW/kW	39,9	39,8	39,8	39,8	40,3	40,6	41,0	40,1	40,5
		Rate of coverage by free cooling	%	87%	104%	95%	87%	73%	80%	72%	79%	72%
		Outdoor temperature for 100% coverage by free cooling	°C	-2,0	0,5	-0,8	-1,9	-4,8	-3,3	-5,1	-3,6	-5,1
		Pressure drops	kPa	65	77	77	77	71	73	70	80	77
		Sound power ⁽¹⁾	dB(A)	79,5	80,5	80,5	80,5	81,0	82,0	82,0	82,0	82,5
		Sound pressure at 10 m ⁽²⁾	dB(A)	60,5	62,0	62,0	62,0	62,5	63,0	63,0	62,5	63,0
Partial free cooling option	CFC1	Maximum rated capacity	kW	98	98	98	98	99	99	99	118	118
		Free cooling EER	kW/kW	42,4	42,4	42,4	42,4	42,7	43,1	43,2	30,4	30,5
		Rate of coverage by free cooling	%	58%	52%	47%	44%	37%	32%	29%	31%	29%
		Pressure drops	kPa	55	55	55	55	54	52	51	56	55
		Sound power ⁽¹⁾	dB(A)	77,5	77,5	77,5	77,5	78,0	78,0	78,0	79,0	79,5
		Sound pressure at 10 m ⁽²⁾	dB(A)	59,0	59,0	59,0	59,0	59,5	59,0	59,0	59,5	60,0

* In accordance with EN14511-3:2022.

CA1 Cooling mode conditions: evaporator water inlet/outlet temperature 17 °C/10 °C, outdoor air temperature at 35 °C, 30% Mono-Ethylene-Glycol, evaporator fouling factor 0 m². kW/W

CFC1 Free cooling mode conditions: evaporator water inlet/outlet temperature 17 °C/10 °C, outdoor air temperature at 0 °C, 30% Mono-Ethylene-Glycol, evaporator fouling factor 0 m². kW/W

(1) In dB ref=10⁻¹² W, 'A' weighted. Declared dual-number noise emission value in accordance with ISO 4871 with an uncertainty of +/-3 dB(A). Measured in accordance with ISO 9614-1 and certified by Eurotest.

(2) In dB ref 20 µPa, (A) weighting. Declared dual-number noise emission value in accordance with ISO 4871 with an uncertainty of +/-3 dB(A). For information, calculated from the sound power Lw(A).



FREE COOLING SYSTEM

AQUACIATPOWER LD	0602R	0650R	0750R	0900R	1100R	1200R	1350R	1400R	1600R
Total free cooling									
Free cooling coil	All-aluminium micro-channel coils (MCHE)								
Quantity	3	4	4	4	4	5	5	6	6
Hydraulic connection									
Connection	in	3"	3"	3"	3"	3"	4"	4"	4"
External diameter	mm	88,9	88,9	88,9	88,9	88,9	114,3	114,3	114,3
Additional water volume	l	60	72	72	72	72	113	113	126
Weight ⁽³⁾									
Additional weight (without water)	kg	262	316	316	316	316	444	447	496
Additional weight (during operation)	kg	324	391	391	391	391	562	565	627
Operation									
Max. operating pressure, water side (without pump)	kPa	600	600	600	600	600	600	600	600
Max. operating pressure, water side (with pump)	kPa	400	400	400	400	400	400	400	400
Partial free cooling									
Free cooling coil	All-aluminium micro-channel coils (MCHE)								
Quantity	2	2	2	2	2	2	2	3	3
Hydraulic connection									
Connection	in	3"	3"	3"	3"	3"	4"	4"	4"
External diameter	mm	88,9	88,9	88,9	88,9	88,9	114,3	114,3	114,3
Additional water volume	l	48	48	48	48	48	58	58	75
Weight ⁽³⁾									
Additional weight (without water)	kg	204	204	204	204	205	260	261	310
Additional weight (during operation)	kg	253	253	253	253	254	321	322	388
Operation									
Max. operating pressure, water side (without pump)	kPa	600	600	600	600	600	600	600	600
Max. operating pressure, water side (with pump)	kPa	400	400	400	400	400	400	400	400

(3) Values are guidelines only. Refer to the unit name plate.



FREE COOLING SYSTEM

AQUACIATPOWER LD			1750R	1800R	2000R	2200R	2400R	2650R	2800R	2950R	3200R	3500R	
Cooling													
Unit + High energy efficiency option Full load performances*	CA1	Maximum rated capacity	kW	475	512	585	652	718	767	827	852	932	994
		EER	kW/kW	3,22	3,16	3,15	3,23	3,22	3,12	3,14	3,10	3,06	2,96
FREE COOLING													
Total free cooling option	CFC1	Maximum rated capacity	kW	425	425	485	546	607	607	667	667	728	728
		Free cooling EER	kW/kW	26,1	26,1	26,0	26,0	25,8	25,8	25,7	25,7	25,4	25,4
		Rate of coverage by free cooling	%	89%	83%	83%	84%	84%	79%	81%	78%	78%	73%
		Outdoor temperature for 100% coverage by free cooling	°C	-1,5	-2,6	-2,6	-2,4	-2,3	-3,3	-3,0	-3,5	-3,5	-4,6
		Pressure drops	kPa	103	102	110	111	120	120	126	126	136	136
		Sound power ⁽¹⁾	dB(A)	91,0	91,0	91,5	92,5	93,0	93,0	93,0	93,0	93,5	94,0
		Sound pressure at 10 m ⁽²⁾	dB(A)	71,0	71,0	71,5	72,0	72,5	72,5	72,0	72,0	72,5	73,0
Partial free cooling option	CFC1	Maximum rated capacity	kW	182	182	242	204	262	262	303	303	364	364
		Free cooling EER	kW/kW	26,5	26,5	26,6	20,4	20,9	20,9	26,7	26,7	26,6	26,6
		Rate of coverage by free cooling	%	38%	35%	41%	31%	36%	34%	37%	36%	39%	37%
		Pressure drops	kPa	75	75	79	77	82	82	80	80	86	86
		Sound power ⁽¹⁾	dB(A)	87,5	87,5	88,5	89,0	90,0	90,0	89,5	89,5	90,5	91,0
		Sound pressure at 10 m ⁽²⁾	dB(A)	67,5	67,5	68,5	68,5	69,5	69,5	68,5	68,5	69,5	70,0
Unit + ultra low noise level option Full load performances*	CA1	Maximum rated capacity	kW	447	481	549	613	677	719	777	798	873	925
		EER	kW/kW	2,94	2,85	2,85	2,94	2,94	2,82	2,84	2,79	2,76	2,63
FREE COOLING													
Total free cooling option	CFC1	Maximum rated capacity	kW	345	345	395	444	493	493	543	543	592	592
		Free cooling EER	kW/kW	41,4	41,5	41,1	41,2	40,7	40,7	40,5	40,5	39,9	39,9
		Rate of coverage by free cooling	%	77%	72%	72%	72%	73%	69%	70%	68%	68%	64%
		Outdoor temperature for 100% coverage by free cooling	°C	-3,8	-5,1	-5,1	-5,0	-4,8	-5,9	-5,6	-6,1	-6,2	-7,3
		Pressure drops	kPa	71	70	75	76	82	82	86	86	93	93
		Sound power ⁽¹⁾	dB(A)	82,5	83,0	83,5	85,0	85,0	85,0	85,5	84,5	85,5	86,0
		Sound pressure at 10 m ⁽²⁾	dB(A)	62,5	63,0	63,5	64,0	64,5	64,5	64,5	63,5	64,5	65,0
Partial free cooling option	CFC1	Maximum rated capacity	kW	148	148	197	166	213	213	247	247	296	296
		Free cooling EER	kW/kW	43,2	43,2	43,6	32,8	34,0	34,0	44,2	44,2	44,3	44,3
		Rate of coverage by free cooling	%	33%	31%	36%	27%	31%	30%	32%	31%	34%	32%
		Pressure drops	kPa	52	52	55	53	56	56	56	56	59	59
		Sound power ⁽¹⁾	dB(A)	79,0	79,5	80,5	81,0	82,0	82,0	82,0	81,0	82,5	83,0
		Sound pressure at 10 m ⁽²⁾	dB(A)	59,0	59,5	60,5	60,5	61,5	61,5	61,0	60,0	61,5	62,0

* In accordance with EN14511-3:2022.

CA1 Cooling mode conditions: evaporator water inlet/outlet temperature 17 °C/10 °C, outdoor air temperature at 35 °C, 30% Mono-Ethylene-Glycol, evaporator fouling factor 0 m². k/W

CFC1 Free cooling mode conditions: evaporator water inlet/outlet temperature 17 °C/10 °C, outdoor air temperature at 0 °C, 30% Mono-Ethylene-Glycol, evaporator fouling factor 0 m². k/W

(1) In dB ref=10⁻¹² W, 'A' weighted. Declared dual-number noise emission value in accordance with ISO 4871 with an uncertainty of +/-3 dB(A). Measured in accordance with ISO 9614-1 and certified by Eurovent.

(2) In dB ref 20 µPa, (A) weighting. Declared dual-number noise emission value in accordance with ISO 4871 with an uncertainty of +/-3 dB(A). For information, calculated from the sound power Lw(A).



FREE COOLING SYSTEM

AQUACIATPOWER LD	1750R	1800R	2000R	2200R	2400R	2650R	2800R	2950R	3200R	3500R
Total free cooling										
Free cooling coil	All-aluminium micro-channel coils (MCHE)									
Quantity	7	7	8	9	10	10	11	11	12	12
Hydraulic connection										
Connection	in	4"	4"	4"	5"	5"	5"	5"	5"	5"
External diameter	mm	114,3	114,3	114,3	139,7	139,7	139,7	139,7	139,7	139,7
Additional water volume	l	200	200	213	298	310	310	351	351	364
Weight ⁽³⁾										
Additional weight (without water)	kg	652	652	704	861	911	911	1044	1044	1093
Additional weight (during operation)	kg	861	861	926	1171	1234	1234	1410	1410	1472
Operation										
Max. operating pressure, water side (without pump)	kPa	600	600	600	600	600	600	600	600	600
Max. operating pressure, water side (with pump)	kPa	400	400	400	400	400	400	400	400	400
Partial free cooling										
Free cooling coil	All-aluminium micro-channel coils (MCHE)									
Quantity	3	3	4	4	5	5	5	5	6	6
Hydraulic connection										
Connection	in	4"	4"	4"	5"	5"	5"	5"	5"	5"
External diameter	mm	114,3	114,3	114,3	139,7	139,7	139,7	139,7	139,7	139,7
Additional water volume	l	101	101	120	186	198	198	205	205	224
Weight ⁽³⁾										
Additional weight (without water)	kg	380	380	432	527	577	577	636	636	686
Additional weight (during operation)	kg	485	485	557	721	784	784	850	850	920
Operation										
Max. operating pressure, water side (without pump)	kPa	600	600	600	600	600	600	600	600	600
Max. operating pressure, water side (with pump)	kPa	400	400	400	400	400	400	400	400	400

(3) Values are guidelines only. Refer to the unit name plate.



FREE COOLING SYSTEM GLYCOL FREE

Physical characteristics of AQUACIATPOWER LD units with Free Cooling option - Glycol Free

AQUACIATPOWER LD			0602R	0650R	0750R	0900R	1100R	1200R	1350R	1400R	1600R	
Cooling												
Standard unit Full load performances*	CA2	Maximum rated capacity	kW	226	247	277	298	364	409	461	502	553
		EER	kW/kW	3,65	3,87	3,64	3,60	3,35	3,52	3,39	3,49	3,38
FREE COOLING												
Glycol-free total free cooling option	CFC2	Maximum rated capacity	kW	264	342	342	342	342	440	440	516	516
		Free cooling EER	kW/kW	25,8	25,0	25,0	25,0	25,6	24,9	25,2	24,7	25,0
		Rate of coverage by free cooling	%	117%	139%	123%	115%	94%	108%	96%	103%	93%
		Outdoor temperature for 100% coverage by free cooling	°C	3,30	6,40	4,40	3,00	-1,50	1,60	-1,00	0,70	-1,60
		Pressure drops	kPa	87,2	141,2	141,2	141,2	121,6	113,5	102,0	140,8	130,7
		Sound power ⁽¹⁾	dB(A)	88,0	89,0	89,0	89,0	89,0	90,0	90,0	90,5	91,0
		Sound pressure at 10 m ⁽²⁾	dB(A)	69,5	70,5	70,5	70,5	70,5	70,5	70,5	71,0	71,5
Unit + ultra low noise level option Full load performances*	CA2	Maximum rated capacity	kW	205	227	253	270	328	370	415	454	500
		EER	kW/kW	3,12	3,43	3,13	3,08	2,76	2,96	2,79	2,92	2,78
FREE COOLING												
Glycol-free total free cooling option	CFC2	Maximum rated capacity	kW	216	282	282	282	282	359	359	424	424
		Free cooling EER	kW/kW	27,6	28,1	28,1	28,1	29,0	26,4	26,8	27,2	27,6
		Rate of coverage by free cooling	%	105%	124%	111%	104%	86%	97%	86%	93%	85%
		Outdoor temperature for 100% coverage by free cooling	°C	1,10	4,50	2,30	0,90	-3,90	-0,70	-3,60	-1,70	-4,20
		Pressure drops	kPa	59,8	98,4	98,4	98,4	84,6	77,2	69,3	96,9	89,9
		Sound power ⁽¹⁾	dB(A)	80,0	81,0	81,0	81,0	81,5	82,5	82,5	82,5	83,0
		Sound pressure at 10 m ⁽²⁾	dB(A)	61,0	62,5	62,5	62,5	63,0	63,0	63,0	62,5	63,0
Total glycol-free free cooling												
Free cooling coil			All-aluminium micro-channel coils (MCHE)									
Coil quantity			3	4	4	4	4	5	5	6	6	
Volume of brine in the intermediate loop	l		87	101	101	101	101	137	137	151	151	
Hydraulic connection												
Connection	in		3"	3"	3"	3"	3"	3"	3"	3"	3"	
External diameter	mm		88,9	88,9	88,9	88,9	88,9	88,9	88,9	88,9	88,9	
Additional water volume	l		51	51	51	51	51	82	82	80	80	
Dimensions												
Additional length	mm		1194	1194	1194	1194	1194	1194	1194	1194	1194	
Weight ⁽³⁾												
Additional weight (without water)	kg		750	804	804	804	804	945	945	995	993	
Additional weight (during operation)	kg		905	972	972	972	977	1192	1201	1260	1268	
Operation												
Pression max. de fonctionnement côté eau (sans pompe)	kPa		1000	1000	1000	1000	1000	1000	1000	1000	1000	
Pression max. de fonctionnement côté eau (avec pompe)	kPa		400	400	400	400	400	400	400	400	400	

* In accordance with EN14511-3:2022.

CA2 Cooling mode conditions: evaporator water inlet/outlet temperature 26°C/20°C, outdoor air temperature at 35 °C, 30%, evaporator fouling factor 0 m². kW

CFC2 Free cooling mode conditions: evaporator water inlet/outlet temperature 26°C/20°C, outdoor air temperature at 0 °C, evaporator fouling factor 0 m². kW

(1) In dB ref=10⁻¹² W, 'A' weighted. Declared dual-number noise emission value in accordance with ISO 4871 with an uncertainty of +/-3 dB(A). Measured in accordance with ISO 9614-1 and certified by Eurovent.

(2) In dB ref 20 µPa, (A) weighting. Declared dual-number noise emission value in accordance with ISO 4871 with an uncertainty of +/-3 dB(A). For information, calculated from the sound power Lw(A).

(3) Values are guidelines only. Refer to the unit name plate.

FREE COOLING SYSTEM GLYCOL FREE

AQUACIATPOWER LD			1750R	1800R	2000R	2200R	2400R	2650R	2800R	2950R	3200R	3500R	
Cooling													
Standard unit Full load performances*	CA2	Maximum rated capacity	kW	598	646	738	798	883	935	1013	1040	1136	1204
		EER	kW/kW	3,52	3,41	3,40	3,41	3,42	3,26	3,28	3,22	3,16	3,00
FREE COOLING													
Glycol-free total free cooling option	CFC2	Maximum rated capacity	kW	634	634	716	800	878	878	968	968	1046	1046
		Free cooling EER	kW/kW	26,2	26,3	26,4	24,9	24,8	24,8	23,1	23,1	22,9	22,9
		Rate of coverage by free cooling	%	106%	98%	97%	100%	99%	94%	96%	93%	92%	87%
		Outdoor temperature for 100% coverage by free cooling	°C	1,30	-0,40	-0,70	0,00	-0,10	-1,50	-1,00	-1,70	-1,90	-3,40
		Pressure drops	kPa	93,1	90,2	108,5	109,3	130,6	130,6	148,8	148,8	172,4	172,4
		Sound power ⁽¹⁾	dB(A)	91,0	91,0	92,0	93,0	93,5	93,5	93,5	93,5	93,5	94,0
		Sound pressure at 10 m ⁽²⁾	dB(A)	71,0	71,0	71,5	72,0	72,5	72,5	72,0	72,0	72,5	73,0
Unit + ultra low noise level option Full load performances*	CA2	Maximum rated capacity	kW	541	583	666	719	797	840	826	924	850	900
		EER	kW/kW	2,93	2,80	2,79	2,84	2,86	2,70	3,06	2,69	3,28	3,09
FREE COOLING													
Glycol-free total free cooling option	CFC2	Maximum rated capacity	kW	514	514	583	650	717	717	788	788	854	854
		Free cooling EER	kW/kW	27,6	27,7	28,6	26,0	26,5	26,5	23,7	23,7	24,0	24,0
		Rate of coverage by free cooling	%	95%	88%	87%	90%	90%	85%	95%	85%	100%	95%
		Outdoor temperature for 100% coverage by free cooling	°C	-1,20	-3,00	-3,30	-2,40	-2,60	-4,00	-1,10	-3,90	0,10	-1,20
		Pressure drops	kPa	62,4	60,4	73,2	73,9	88,8	88,8	100,5	100,5	117,1	117,1
		Sound power ⁽¹⁾	dB(A)	83,0	83,5	84,0	85,5	86,0	86,0	87,0	86,0	87,0	87,5
		Sound pressure at 10 m ⁽²⁾	dB(A)	63,0	63,5	64,0	65,0	65,5	65,5	66,0	65,0	66,0	66,5
Total glycol-free free cooling													
Free cooling coil			All-aluminium micro-channel coils (MCHE)										
Coil quantity			7	7	8	9	10	10	11	11	12	12	
Volume of brine in the intermediate loop	l		229	229	244	293	302	302	348	348	362	362	
Hydraulic connection													
Connection	in		4"	4"	4"	5"	5"	5"	5"	5"	5"	5"	
External diameter	mm		114,3	114,3	114,3	139,7	139,7	139,7	139,7	139,7	139,7	139,7	
Additional water volume	l		135	135	133	172	172	172	199	199	199	199	
Dimensions													
Additional length	mm		1194	1194	1194	1194	1194	1194	1194	1194	1194	1194	
Weight ⁽³⁾													
Additional weight (without water)	kg		1223	1224	1277	1430	1480	1480	1599	1599	1650	1650	
Additional weight (during operation)	kg		1655	1660	1731	1977	2037	2037	2230	2230	2295	2295	
Operation													
Pression max. de fonctionnement côté eau (sans pompe)	kPa		1000	1000	1000	1000	1000	1000	1000	1000	1000	1000	
Pression max. de fonctionnement côté eau (avec pompe)	kPa		400	400	400	400	400	400	400	400	400	400	

* In accordance with EN14511-3:2022.

CA2 Cooling mode conditions: evaporator water inlet/outlet temperature 26°C/20°C, outdoor air temperature at 35 °C, 30%, evaporator fouling factor 0 m². kW

CFC2 Free cooling mode conditions: evaporator water inlet/outlet temperature 26°C/20°C, outdoor air temperature at 0 °C, evaporator fouling factor 0 m². kW

(1) In dB ref=10⁻¹² W, 'A' weighted. Declared dual-number noise emission value in accordance with ISO 4871 with an uncertainty of +/-3 dB(A). Measured in accordance with ISO 9614-1 and certified by Eurovent.

(2) In dB ref 20 µPa, (A) weighting. Declared dual-number noise emission value in accordance with ISO 4871 with an uncertainty of +/-3 dB(A). For information, calculated from the sound power L_w(A).

(3) Values are guidelines only. Refer to the unit name plate.



FREE COOLING SYSTEM

Free cooling operating limits

LD 602R to 3500R units

Water type heat exchanger		Minimum	Maximum
Water inlet temperature at start-up	°C	8	40
Water outlet temperature during operation	°C	5	20
Air-cooled exchanger		Minimum	Maximum
Outdoor ambient operating temperature			
LD units - Full load	°C	-20	47
LD units - Part load	°C	-20	52 ⁽¹⁾

(1) Part load operation permitted above an outdoor air temperature of 47 °C. Contact the manufacturer to select a unit using the electronic catalogue.

All the free cooling units must be protected against freezing with 30% ethylene glycol in the cooling loop circuit (recommended value).

XTRA FAN OPERATING PRESSURE VENTILATION

The **AQUACIAT^{POWER}** range can be equipped as an option with XTRAFAN operating pressure ventilation.

■ Functions

The XTRAFAN offers a wide range of functions, making a whole host of flexible installation conditions possible, such as:

- The option of installation in a confined space, for example on a terrace surrounded by walls, where only an air supply with static pressure of between 100 and 200 pascals within a duct enables use without recirculation or mixing of air at the condenser intake,
- Installation in an urban area in which noise is a particular issue, where operation is only possible by adapting a sound trap to the supply air,
- A self-adjusting variable speed function which allows "all-season" cooling, fully secured for industrial processes, including during harsh winter conditions with an external temperature of -20 °C,
- The freedom to precisely adjust the ventilation speed on-site to what is "strictly necessary" to obtain the optimum air supply pressure, or the maximum acceptable noise level for the site on which the unit is located,
- An improvement in the EER and electrical consumption for the unit, in direct proportion to the load required by the installation.

The various performances (cooling capacity, heating capacity, input power, energy efficiency) depend on the rotation speed of the fans, and therefore on the desired operating pressure in the duct:

- At an operating pressure of between 0 and 100 Pa, the machine performances are barely affected
- At an operating pressure of between 100 and 200 Pa, the machine performances may be significantly affected, particularly according to the air and water temperature conditions.

The sound level at the duct outlet and the level radiated around the machine depend on the operating pressure.

Refer to the selection tool to evaluate the estimated impact of the ducting system on the machine's operating conditions.

■ Precautions for installation

On-site installation of a packaged reversible air-to-water unit requires some safety measures to be taken, particularly if it is installed in a machine room. For example, draining of condensates specific to these units, including at very low outdoor temperatures.

During defrosting cycles, reversible units are liable to discharge a large amount of water onto the ground, which must be drained, as well as steam from the fan discharge which can damage the air discharge ducts. The ground supporting the unit must be perfectly watertight and capable of collecting and draining the defrosted water, including during freezing periods. It is recommended that the unit is raised by approximately 300 mm.

If an air discharge duct is installed on site, its weight must not be supported by the roof of the unit. Each fan must be connected independently.

The duct must be connected to the unit using a flexible supply air sleeve, included in the option

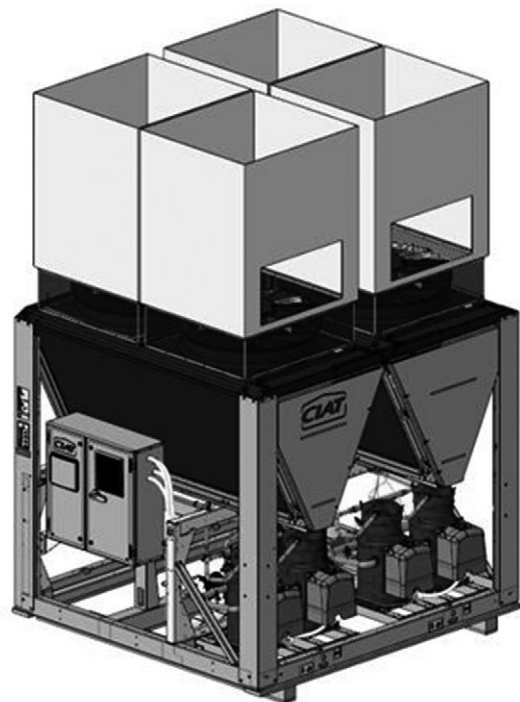



INTELLIGENTLY DESIGNED ACOUSTICS

To comply with the various restrictions on integration, the **AQUACIAT^{POWER}** has two sound finish levels, enabling it to be easily integrated into a number of zones without causing disruption to users or their neighbours.

■ Basic version

The distinguishing feature of the **AQUACIAT^{POWER}** range is its rigorous design incorporating "noiseless" assembly techniques to reduce vibrations and sources of noise:

- New-generation scroll compressors with a continuous scrolling motion to lessen vibrations
- Compressor structure separated from the unit by anti-vibration mounts
- Pipes separated from the unit structure
- Fans made from a synthetic material, with aerodynamic blades offering an optimised profile. Optimised coil-fan combination, the result of many hours of study of the thermal and acoustic properties in our Research and Innovation Centre, to ensure a linear flow of air without turbulence, to limit noise to an acceptable acoustic spectrum.
- Even with the basic version, the fans rotate at low speed to guarantee maximum comfort
- The Connect Touch controller automatically adjusts the fan air flow rate according to the outdoor air temperature and the unit's load rate which enables the sound level to be significantly reduced, particularly at night, mid-season, morning and evening, which totals more than 75% of the time the unit is used

■ Very Low Noise option

In this version, the compressors are fitted inside an insulated soundproof box, and the rotation speed of the fans is kept to a minimum, but the output power and thermal performance remains the same as the basic version.

VERY LOW NOISE

)))
-3 to -4 dB(A)
 Thanks to the compressor enclosure

■ Ultra Low Noise option

In this version, the compressor soundproof box and all sources of vibration which generate noise have had a special coating applied, and the rotation speed of the fans is kept to a minimum, but the output power and thermal performance remains the same as the basic version.

ULTRA LOW NOISE

)))
-5 to -6 dB(A)
 Thanks to a specific soundproof box and an acoustic and vibration treatment on the structure

■ Night mode

The **AQUACIAT^{POWER}** has a Night Mode function enabling the sound level to be limited at night or when the building is unoccupied (according to the user programming) by controlling the fan rotation speed and output.

NIGHT MODE

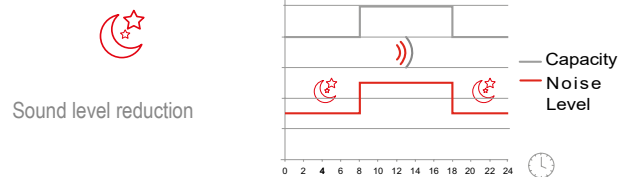

■ Acoustic signature

As important as the sound power level, the acoustic signature reflects the noise disturbance generated by the unit.

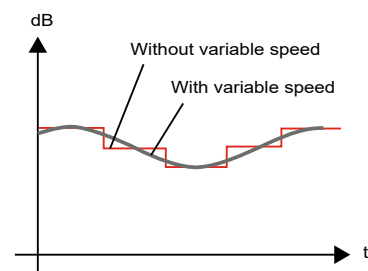
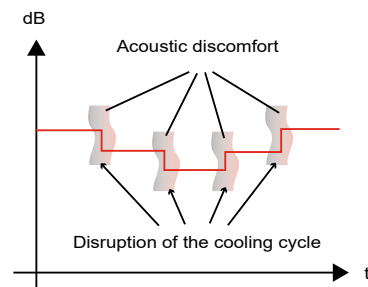

The **AQUACIAT^{POWER}** can be equipped as an option with a variable-speed motor, enabling soft starting of the fan (all-season operation).

It avoids the increases in noise linked to the on/off sequences, thereby improving the unit's acoustic signature.

Installing a variable-speed pump also reduces the noise level of the pumping function by adjusting the pump speed to the exact requirements. The soft start improves the signature and reduces nuisance noise.

With all these benefits and its three acoustic finish levels, the **AQUACIAT^{POWER}** range can be integrated into any site, ensuring any constraints in terms of the sound environment can be met while guaranteeing optimal comfort for both users and their neighbours, allowing customers in the hotel industry to enjoy their rest, and promoting rest and recovery for users in the hospital sector.



SOUND LEVELS - COOLING ONLY

Standard unit

■ Sound power level (LW)

AQUACIATPOWER LD Standard unit	Power level spectrum ⁽¹⁾									Global sound power level ⁽²⁾	
		63 Hz	125 Hz	250 Hz	500 Hz	1 kHz	2 kHz	4 kHz	8 kHz		
0602R	dB	83,0	77,0	81,0	86,0	85,0	81,0	73,0	70,0	dB(A)	88,5
0650R	dB	85,0	80,5	83,0	86,5	84,5	82,5	73,0	70,5	dB(A)	89,0
0750R	dB	85,0	80,5	83,0	86,5	84,5	82,5	73,0	70,5	dB(A)	89,0
0900R	dB	83,5	77,5	82,0	86,5	85,5	82,0	74,0	70,5	dB(A)	89,5
1100R	dB	84,5	81,0	84,0	87,0	85,0	83,0	73,5	71,0	dB(A)	89,5
1200R	dB	85,5	81,5	85,0	88,0	86,0	84,0	74,5	72,0	dB(A)	90,5
1350R	dB	85,5	81,5	85,0	88,0	86,0	84,0	74,5	72,0	dB(A)	90,5
1400R	dB	85,5	79,5	84,0	88,5	87,5	83,5	75,5	72,5	dB(A)	91,0
1600R	dB	86,0	82,0	85,0	88,0	86,5	84,5	74,5	72,5	dB(A)	91,0
1750R	dB	86,0	80,0	84,5	89,0	88,0	84,5	76,5	73,0	dB(A)	91,5
1800R	dB	86,5	82,5	86,0	88,5	87,0	85,0	75,5	73,0	dB(A)	91,5
2000R	dB	87,0	83,5	86,5	89,5	87,5	85,5	76,0	73,5	dB(A)	92,0
2200R	dB	97,0	99,5	98,0	90,5	87,0	92,0	83,5	77,5	dB(A)	96,5
2400R	dB	90,5	85,5	88,5	92,5	89,0	93,0	82,0	79,5	dB(A)	96,5
2650R	dB	97,5	100,0	98,5	90,5	87,0	92,5	83,5	77,5	dB(A)	97,0
2800R	dB	91,0	86,5	89,5	93,5	89,5	93,5	82,5	80,0	dB(A)	97,0
2950R	dB	98,0	100,5	99,0	91,0	87,5	93,0	84,5	78,5	dB(A)	97,5
3200R	dB	91,0	86,5	89,5	93,5	89,5	93,5	82,5	80,0	dB(A)	97,5
3500R	dB	91,5	87,0	90,0	94,0	90,0	94,0	83,0	80,5	dB(A)	98,0

(1) In dB ref=10⁻¹² W, as a guideline. Measured in accordance with ISO 9614-1.

(2) In dB ref=10⁻¹² W, (A) weighting, with an uncertainty of +/-3 dB. Measured in accordance with ISO 9614-1 and certified by Eurovent.

■ Sound pressure level (Lp)

Measurement conditions: Free field, 10 metres from machine, 1.5 metres above floor level, directivity 2

Note: the sound pressure levels depend on the installation conditions of each system. As such, the levels listed here are given for information only. Only the sound power levels are comparable and certified.

AQUACIATPOWER LD Standard unit	Sound pressure spectrum ⁽¹⁾									Global sound pressure spectrum ⁽²⁾	
		63 Hz	125 Hz	250 Hz	500 Hz	1 kHz	2 kHz	4 kHz	8 kHz		
0602R	dB	51,0	45,0	49,0	54,0	53,0	49,0	41,0	38,0	dB(A)	56,5
0650R	dB	53,0	48,5	51,0	54,5	52,5	50,5	41,0	38,5	dB(A)	57,0
0750R	dB	53,0	48,5	51,0	54,5	52,5	50,5	41,0	38,5	dB(A)	57,0
0900R	dB	51,5	45,5	50,0	54,5	53,5	50,0	42,0	38,5	dB(A)	57,5
1100R	dB	52,5	49,0	52,0	55,0	53,0	51,0	41,5	39,0	dB(A)	57,5
1200R	dB	53,5	49,5	53,0	56,0	54,0	52,0	42,5	40,0	dB(A)	58,5
1350R	dB	53,5	49,5	53,0	56,0	54,0	52,0	42,5	40,0	dB(A)	58,5
1400R	dB	53,5	47,5	52,0	56,5	55,5	51,5	43,5	40,5	dB(A)	59,0
1600R	dB	54,0	50,0	53,0	56,0	54,5	52,5	42,5	40,5	dB(A)	58,5
1750R	dB	53,5	47,5	52,0	56,5	55,5	52,0	44,0	40,5	dB(A)	59,5
1800R	dB	54,0	50,0	53,5	56,0	54,5	52,5	43,0	40,5	dB(A)	59,0
2000R	dB	54,5	51,0	54,0	57,0	55,0	53,0	43,5	41,0	dB(A)	60,0
2200R	dB	64,5	67,0	65,5	58,0	54,5	59,5	51,0	45,0	dB(A)	64,0
2400R	dB	58,0	53,0	56,0	60,0	56,5	60,5	49,5	47,0	dB(A)	64,0
2650R	dB	65,0	67,5	66,0	58,0	54,5	60,0	51,0	45,0	dB(A)	64,5
2800R	dB	58,5	54,0	57,0	61,0	57,0	61,0	50,0	47,5	dB(A)	65,0
2950R	dB	65,5	68,0	66,5	58,5	55,0	60,5	52,0	46,0	dB(A)	65,0
3200R	dB	58,5	54,0	57,0	61,0	57,0	61,0	50,0	47,5	dB(A)	65,0
3500R	dB	59,0	54,5	57,5	61,5	57,5	61,5	50,5	48,0	dB(A)	65,5

(1) In dB ref=2x10⁻⁵ Pa, as a guideline.

(2) In dB ref=2x10⁻⁵ Pa, (A) weighting with an uncertainty of +/-3 dB.

SOUND LEVELS - COOLING ONLY

Unit + High temperature option/Rated high performance

■ Sound power level (LW)

AQUACIATPOWER LD Unit + High temperature option/Rated high performance	Power level spectrum ⁽¹⁾									Global sound power level ⁽²⁾	
		63 Hz	125 Hz	250 Hz	500 Hz	1 kHz	2 kHz	4 kHz	8 kHz		
0602R	dB	82,5	83,5	83,5	87,0	87,5	83,0	75,5	73,5	dB(A)	91,0
0650R	dB	84,0	85,0	85,0	87,5	88,0	84,0	75,5	74,0	dB(A)	90,5
0750R	dB	84,0	85,0	85,0	87,5	88,0	84,0	75,5	74,0	dB(A)	90,5
0900R	dB	83,5	84,5	85,0	88,5	89,0	84,5	76,5	74,5	dB(A)	92,0
1100R	dB	84,0	85,0	85,5	88,0	88,5	85,0	76,0	74,5	dB(A)	92,0
1200R	dB	85,0	86,0	86,5	89,0	89,5	85,5	77,0	75,5	dB(A)	93,0
1350R	dB	85,0	86,0	86,5	89,0	89,5	85,5	77,0	75,5	dB(A)	93,0
1400R	dB	85,0	86,0	86,0	89,5	90,0	85,5	78,0	76,0	dB(A)	93,5
1600R	dB	86,0	87,0	87,5	90,0	90,0	86,5	77,5	76,0	dB(A)	93,5
1750R	dB	85,5	86,5	87,0	90,0	91,0	86,0	78,5	76,5	dB(A)	94,0
1800R	dB	86,0	87,0	87,5	90,0	90,5	86,5	78,0	76,5	dB(A)	94,0
2000R	dB	86,5	87,5	88,0	90,5	91,0	87,5	78,5	77,0	dB(A)	94,5
2200R	dB	96,5	99,5	98,0	92,0	91,5	92,0	84,0	79,5	dB(A)	97,5
2400R	dB	90,0	89,5	90,0	93,5	92,5	93,0	83,0	81,0	dB(A)	97,5
2650R	dB	97,5	100,5	98,5	92,5	92,0	93,0	84,5	80,0	dB(A)	98,0
2800R	dB	90,0	89,5	90,0	93,5	92,5	93,0	83,0	81,0	dB(A)	98,0
2950R	dB	97,5	100,5	99,0	92,5	92,0	93,0	84,5	80,0	dB(A)	98,5
3200R	dB	90,5	90,0	90,5	94,0	93,0	94,0	83,5	81,5	dB(A)	98,5
3500R	dB	91,0	90,5	91,0	94,5	93,5	94,5	84,0	82,0	dB(A)	99,0

(1) In dB ref=10⁻¹² W, as a guideline. Measured in accordance with ISO 9614-1.

(2) In dB ref=10⁻¹² W, (A) weighting, with an uncertainty of +/-3 dB. Measured in accordance with ISO 9614-1 and certified by Eurovent.

■ Sound pressure level (Lp)

Measurement conditions: Free field, 10 metres from machine, 1.5 metres above floor level, directivity 2

Note: the sound pressure levels depend on the installation conditions of each system. As such, the levels listed here are given for information only. Only the sound power levels are comparable and certified.

AQUACIATPOWER LD Unit + High temperature option/Rated high performance	Sound pressure spectrum ⁽¹⁾									Global sound pressure spectrum ⁽²⁾	
		63 Hz	125 Hz	250 Hz	500 Hz	1 kHz	2 kHz	4 kHz	8 kHz		
0602R	dB	50,5	51,5	51,5	55,0	55,5	51,0	43,5	41,5	dB(A)	58,5
0650R	dB	52,0	53,0	53,0	55,5	56,0	52,0	43,5	42,0	dB(A)	59,5
0750R	dB	52,0	53,0	53,0	55,5	56,0	52,0	43,5	42,0	dB(A)	59,5
0900R	dB	51,5	52,5	53,0	56,5	57,0	52,5	44,5	42,5	dB(A)	60,0
1100R	dB	52,0	53,0	53,5	56,0	56,5	53,0	44,0	42,5	dB(A)	60,0
1200R	dB	53,0	54,0	54,5	57,0	57,5	53,5	45,0	43,5	dB(A)	60,5
1350R	dB	53,0	54,0	54,5	57,0	57,5	53,5	45,0	43,5	dB(A)	60,5
1400R	dB	53,0	54,0	54,0	57,5	58,0	53,5	46,0	44,0	dB(A)	61,0
1600R	dB	54,0	55,0	55,5	58,0	58,0	54,5	45,5	44,0	dB(A)	61,5
1750R	dB	53,0	54,0	54,5	57,5	58,5	53,5	46,0	44,0	dB(A)	61,5
1800R	dB	53,5	54,5	55,0	57,5	58,0	54,0	45,5	44,0	dB(A)	61,5
2000R	dB	54,0	55,0	55,5	58,0	58,5	55,0	46,0	44,5	dB(A)	62,0
2200R	dB	64,0	67,0	65,5	59,5	59,0	59,5	51,5	47,0	dB(A)	65,0
2400R	dB	57,5	57,0	57,5	61,0	60,0	60,5	50,5	48,5	dB(A)	65,0
2650R	dB	65,0	68,0	66,0	60,0	59,5	60,5	52,0	47,5	dB(A)	66,0
2800R	dB	57,5	57,0	57,5	61,0	60,0	60,5	50,5	48,5	dB(A)	65,0
2950R	dB	65,0	68,0	66,5	60,0	59,5	60,5	52,0	47,5	dB(A)	66,0
3200R	dB	58,0	57,5	58,0	61,5	60,5	61,5	51,0	49,0	dB(A)	66,0
3500R	dB	58,5	58,0	58,5	62,0	61,0	62,0	51,5	49,5	dB(A)	66,5

(1) In dB ref=2x10⁻⁵ Pa, as a guideline.

(2) In dB ref=2x10⁻⁵ Pa, (A) weighting with an uncertainty of +/-3 dB.

SOUND LEVELS - COOLING ONLY

Unit + Very Low Noise option

■ Sound power level (LW)

AQUACIATPOWER LD Unit + Very Low Noise option	Power level spectrum ⁽¹⁾									Global sound power level ⁽²⁾	
		63 Hz	125 Hz	250 Hz	500 Hz	1 kHz	2 kHz	4 kHz	8 kHz		
0602R	dB	75,5	80	83	85	80	75	69	74	dB(A)	85,0
0700R	dB	76,5	81	84	86	81	76	70	75	dB(A)	86,0
0800R	dB	77	82	85	86	82	77	71	75	dB(A)	86,5
0900R	dB	77,5	82	85	87	82	77	71	76	dB(A)	87,0
1000R	dB	78	82	85	87	81	78	71	75	dB(A)	87,0
1150R	dB	78,5	83	86	88	83	79	72	77	dB(A)	88,0
1250R	dB	79	83	86	88	82	79	72	76	dB(A)	88,0
1400R	dB	79,5	84	87	89	84	79	73	78	dB(A)	89,0
1500R	dB	80	84	87	89	83	80	73	77	dB(A)	89,0
1600R	dB	80	85	87	89	84	80	73	78	dB(A)	89,5
1750R	dB	81	85	88	90	84	81	74	78	dB(A)	90,0
2000R	dB	81	85	88	90	84	81	74	78	dB(A)	90,0
2200R	dB	104,0	98,0	95,5	88,0	83,0	86,0	79,5	73,5	dB(A)	92,5
2400R	dB	95,0	88,0	86,5	90,5	85,5	87,5	78,5	76,0	dB(A)	92,5
2650R	dB	104,5	98,0	95,5	88,0	83,0	86,5	79,5	74,0	dB(A)	93,0
2800R	dB	95,0	88,0	86,5	91,0	85,5	87,5	78,5	76,0	dB(A)	93,0
2950R	dB	105,0	99,0	96,5	88,5	83,5	87,0	80,5	74,5	dB(A)	93,5
3200R	dB	95,5	88,5	87,0	91,5	86,0	88,0	79,0	77,0	dB(A)	93,5
3500R	dB	96,5	89,5	88,0	92,5	87,0	89,0	80,0	78,0	dB(A)	94,5

(1) In dB ref=10⁻¹² W, as a guideline. Measured in accordance with ISO 9614-1.

(2) In dB ref=10⁻¹² W, (A) weighting, with an uncertainty of +/-3 dB. Measured in accordance with ISO 9614-1 and certified by Eurovent.

■ Sound pressure level (Lp)

Measurement conditions: Free field, 10 metres from machine, 1.5 metres above floor level, directivity 2

Note: the sound pressure levels depend on the installation conditions of each system. As such, the levels listed here are given for information only. Only the sound power levels are comparable and certified.

AQUACIATPOWER LD Unit + Very Low Noise option	Sound pressure spectrum ⁽¹⁾									Global sound pressure spectrum ⁽²⁾	
		63 Hz	125 Hz	250 Hz	500 Hz	1 kHz	2 kHz	4 kHz	8 kHz		
0602R	dB	53,0	45,5	47,5	52,5	48,5	44,0	37,5	33,5	dB(A)	53,0
0650R	dB	54,0	48,0	49,0	52,5	48,5	45,0	37,0	34,0	dB(A)	53,5
0750R	dB	54,0	48,0	49,0	52,5	48,5	45,0	37,0	34,0	dB(A)	53,5
0900R	dB	54,5	47,0	48,5	54,0	50,0	45,0	38,5	35,0	dB(A)	54,5
1100R	dB	55,5	49,5	50,5	54,0	49,5	46,5	38,5	35,5	dB(A)	54,5
1200R	dB	56,5	50,5	51,5	55,0	50,5	47,5	39,5	36,5	dB(A)	55,5
1350R	dB	56,5	50,5	51,5	55,0	50,5	47,5	39,5	36,5	dB(A)	55,5
1400R	dB	55,5	48,0	50,0	55,0	51,0	46,5	40,0	36,0	dB(A)	55,5
1600R	dB	56,5	50,5	51,5	55,0	51,0	48,0	40,0	36,5	dB(A)	56,0
1750R	dB	56,0	48,5	50,0	55,5	51,5	46,5	40,0	36,0	dB(A)	56,0
1800R	dB	57,0	51,0	52,0	55,5	51,0	48,0	40,0	37,0	dB(A)	56,5
2000R	dB	57,5	51,5	52,5	56,0	51,5	48,5	40,5	37,5	dB(A)	57,0
2200R	dB	71,5	65,5	63,0	55,5	50,5	53,5	47,0	41,0	dB(A)	60,5
2400R	dB	62,5	55,5	54,0	58,0	53,0	55,0	46,0	43,5	dB(A)	60,0
2650R	dB	72,0	65,5	63,0	55,5	50,5	54,0	47,0	41,5	dB(A)	60,5
2800R	dB	62,5	55,5	54,0	58,5	53,0	55,0	46,0	43,5	dB(A)	60,0
2950R	dB	72,5	66,5	64,0	56,0	51,0	54,5	48,0	42,0	dB(A)	61,0
3200R	dB	63,0	56,0	54,5	59,0	53,5	55,5	46,5	44,5	dB(A)	60,5
3500R	dB	64,0	57,0	55,5	60,0	54,5	56,5	47,5	45,5	dB(A)	61,5

(1) In dB ref=2x10⁻⁵ Pa, as a guideline.

(2) In dB ref=2x10⁻⁵ Pa, (A) weighting with an uncertainty of +/-3 dB.

SOUND LEVELS - COOLING ONLY

Unit + Ultra Low Noise option

■ Sound power level (LW)

AQUACIAT ^{POWER} LD Unit + Ultra Low Noise option	Power level spectrum ⁽¹⁾									Global sound power level ⁽²⁾	
		63 Hz	125 Hz	250 Hz	500 Hz	1 kHz	2 kHz	4 kHz	8 kHz		
0602R	dB	82,5	76,5	77,5	81,5	80,0	74,0	66,5	63,0	dB(A)	83,5
0650R	dB	83,0	79,5	80,0	82,5	79,0	74,5	67,0	63,5	dB(A)	83,5
0750R	dB	83,0	79,5	80,0	82,5	79,0	74,5	67,0	63,5	dB(A)	83,5
0900R	dB	83,5	78,0	79,0	83,0	81,5	75,5	67,5	64,0	dB(A)	84,5
1100R	dB	83,5	80,5	81,5	83,5	80,0	76,0	68,5	65,0	dB(A)	84,5
1200R	dB	84,5	81,5	82,5	84,5	81,0	77,0	69,5	66,0	dB(A)	85,5
1350R	dB	84,5	81,5	82,5	84,5	81,0	77,0	69,5	66,0	dB(A)	85,5
1400R	dB	85,0	79,0	80,0	84,0	82,5	76,5	69,0	65,5	dB(A)	86,0
1600R	dB	84,5	82,0	82,5	85,0	81,0	77,0	70,0	66,5	dB(A)	86,0
1750R	dB	85,5	80,0	80,5	85,0	83,5	77,0	69,5	66,0	dB(A)	86,5
1800R	dB	85,5	82,5	83,5	85,5	82,0	78,0	70,5	67,0	dB(A)	86,5
2000R	dB	86,0	83,0	84,0	86,0	82,5	78,5	71,0	67,5	dB(A)	87,0
2200R	dB	87,0	84,0	84,5	86,0	84,5	83,5	81,0	76,0	dB(A)	90,0
2400R	dB	90,0	85,0	87,5	87,5	85,0	82,0	75,5	73,5	dB(A)	90,0
2650R	dB	87,5	84,5	85,0	87,0	85,0	84,0	82,0	77,0	dB(A)	90,5
2800R	dB	91,0	85,5	88,0	88,0	85,5	82,5	76,0	74,0	dB(A)	90,5
2950R	dB	87,0	84,0	84,5	86,5	84,5	83,5	81,5	76,5	dB(A)	90,5
3200R	dB	91,0	86,0	88,0	88,0	85,5	82,5	76,5	74,0	dB(A)	90,5
3500R	dB	91,5	86,5	88,5	88,5	86,0	83,0	77,0	74,5	dB(A)	91,0

(1) In dB ref=10⁻¹² W, as a guideline. Measured in accordance with ISO 9614-1.

(2) In dB ref=10⁻¹² W, (A) weighting, with an uncertainty of +/-3 dB. Measured in accordance with ISO 9614-1 and certified by Eurovent.

■ Sound pressure level (Lp)

Measurement conditions: Free field, 10 metres from machine, 1.5 metres above floor level, directivity 2

Note: the sound pressure levels depend on the installation conditions of each system. As such, the levels listed here are given for information only. Only the sound power levels are comparable and certified.

AQUACIAT ^{POWER} LD Unit + Ultra Low Noise option	Sound pressure spectrum ⁽¹⁾									Global sound pressure spectrum ⁽²⁾	
		63 Hz	125 Hz	250 Hz	500 Hz	1 kHz	2 kHz	4 kHz	8 kHz		
0602R	dB	50,5	44,5	45,5	49,5	48,0	42,0	34,5	31,0	dB(A)	51,5
0650R	dB	51,0	47,5	48,0	50,5	47,0	42,5	35,0	31,5	dB(A)	51,5
0750R	dB	51,0	47,5	48,0	50,5	47,0	42,5	35,0	31,5	dB(A)	51,5
0900R	dB	51,5	46,0	47,0	51,0	49,5	43,5	35,5	32,0	dB(A)	52,5
1100R	dB	51,5	48,5	49,5	51,5	48,0	44,0	36,5	33,0	dB(A)	52,5
1200R	dB	52,5	49,5	50,5	52,5	49,0	45,0	37,5	34,0	dB(A)	53,5
1350R	dB	52,5	49,5	50,5	52,5	49,0	45,0	37,5	34,0	dB(A)	53,5
1400R	dB	53,0	47,0	48,0	52,0	50,5	44,5	37,0	33,5	dB(A)	53,5
1600R	dB	52,5	50,0	50,5	53,0	49,0	45,0	38,0	34,5	dB(A)	53,5
1750R	dB	53,0	47,5	48,0	52,5	51,0	44,5	37,0	33,5	dB(A)	54,5
1800R	dB	53,0	50,0	51,0	53,0	49,5	45,5	38,0	34,5	dB(A)	54,0
2000R	dB	53,5	50,5	51,5	53,5	50,0	46,0	38,5	35,0	dB(A)	55,0
2200R	dB	54,5	51,5	52,0	53,5	52,0	51,0	48,5	43,5	dB(A)	57,5
2400R	dB	57,5	52,5	55,0	55,0	52,5	49,5	43,0	41,0	dB(A)	57,5
2650R	dB	55,0	52,0	52,5	54,5	52,5	51,5	49,5	44,5	dB(A)	58,0
2800R	dB	58,5	53,0	55,5	55,5	53,0	50,0	43,5	41,5	dB(A)	58,0
2950R	dB	54,5	51,5	52,0	54,0	52,0	51,0	49,0	44,0	dB(A)	57,5
3200R	dB	58,5	53,5	55,5	55,5	53,0	50,0	44,0	41,5	dB(A)	58,0
3500R	dB	59,0	54,0	56,0	56,0	53,5	50,5	44,5	42,0	dB(A)	58,5

(1) In dB ref=2x10⁻⁵ Pa, as a guideline.

(2) In dB ref=2x10⁻⁵ Pa, (A) weighting with an uncertainty of +/-3 dB.

SOUND LEVELS - REVERSIBLE HEAT PUMP

Standard unit

■ Sound power level (LW) - Cooling mode

AQUACIATPOWER ILD Standard unit	Power level spectrum ⁽¹⁾									Global sound power level ⁽²⁾	
		63 Hz	125 Hz	250 Hz	500 Hz	1 kHz	2 kHz	4 kHz	8 kHz		
0602R	dB	75	81	84	86	85	81	72	76	dB(A)	88,0
0700R	dB	75	82	84	87	84	81	73	76	dB(A)	88,5
0800R	dB	76	82	85	87	85	81	73	76	dB(A)	89,0
0900R	dB	76	83	85	88	86	82	74	77	dB(A)	89,5
1000R	dB	76	82	85	88	85	82	73	77	dB(A)	89,5
1150R	dB	77	84	86	89	86	83	75	78	dB(A)	90,5
1250R	dB	77	84	86	90	87	84	75	78	dB(A)	91,0
1400R	dB	78	85	87	90	87	84	76	79	dB(A)	91,5
1500R	dB	78	84	87	90	87	84	75	79	dB(A)	91,5
1600R	dB	78	85	88	90	88	85	76	79	dB(A)	92,0
1750R	dB	79	85	88	91	88	85	76	79	dB(A)	92,5
2000R	dB	79	86	88	91	89	86	77	80	dB(A)	93,0
2300R	dB	80	87	89	92	89	86	78	81	dB(A)	93,5
2500R	dB	80	87	89	93	90	87	78	81	dB(A)	94,0
2800R	dB	81	88	90	93	90	87	79	82	dB(A)	94,5
3000R	dB	81	87	90	93	90	87	78	82	dB(A)	94,5
3200R	dB	81	88	91	93	91	88	79	82	dB(A)	95,0
3500R	dB	82	88	91	94	91	88	79	82	dB(A)	95,5
4000R	dB	82	89	91	94	92	89	80	83	dB(A)	96,0

(1) In dB ref=10⁻¹² W, as a guideline. Measured in accordance with ISO 9614-1.

(2) In dB ref=10⁻¹² W, (A) weighting, with an uncertainty of +/-3 dB. Measured in accordance with ISO 9614-1 and certified by Eurovent.

■ Sound pressure level (Lp) - Cooling mode

Measurement conditions: Free field, 10 metres from machine, 1.5 metres above floor level, directivity 2

Note: the sound pressure levels depend on the installation conditions of each system. As such, the levels listed here are given for information only. Only the sound power levels are comparable and certified.

AQUACIATPOWER ILD Standard unit	Sound pressure spectrum ⁽¹⁾									Global sound pressure spectrum ⁽²⁾	
		63 Hz	125 Hz	250 Hz	500 Hz	1 kHz	2 kHz	4 kHz	8 kHz		
0602R	dB	43	49	52	54	53	49	40	44	dB(A)	56,0
0700R	dB	43	50	52	55	52	49	41	44	dB(A)	56,5
0800R	dB	44	50	53	55	53	49	41	44	dB(A)	57,0
0900R	dB	44	51	53	56	54	50	42	45	dB(A)	57,5
1000R	dB	44	50	53	56	53	50	41	45	dB(A)	57,5
1150R	dB	45	52	54	57	54	51	43	46	dB(A)	58,5
1250R	dB	45	52	54	58	55	52	43	46	dB(A)	59,0
1400R	dB	46	53	55	58	55	52	44	47	dB(A)	59,5
1500R	dB	46	52	55	58	55	52	43	47	dB(A)	59,5
1600R	dB	46	52	55	58	55	52	44	47	dB(A)	60,0
1750R	dB	46	53	55	58	56	53	44	47	dB(A)	60,0
2000R	dB	47	53	56	59	56	53	44	47	dB(A)	60,5
2300R	dB	48	55	57	60	57	54	46	49	dB(A)	61,5
2500R	dB	48	55	57	61	58	55	46	49	dB(A)	62,0
2800R	dB	49	56	58	61	58	55	47	50	dB(A)	62,5
3000R	dB	49	55	58	61	58	55	46	50	dB(A)	62,5
3200R	dB	49	55	58	61	58	55	47	50	dB(A)	63,0
3500R	dB	49	56	58	61	59	56	47	50	dB(A)	63,0
4000R	dB	50	56	59	62	59	56	47	50	dB(A)	63,5

(1) In dB ref=2x10⁻⁵ Pa, as a guideline.

(2) In dB ref=2x10⁻⁵ Pa, (A) weighting with an uncertainty of +/-3 dB.

SOUND LEVELS - REVERSIBLE HEAT PUMP

Unit + High temperature option/Rated high performance

■ Sound power level (LW) - Cooling mode

AQUACIAT ^{POWER} ILD Unit + High temperature option/Rated high performance	Power level spectrum ⁽¹⁾									Global sound power level ⁽²⁾	
		63 Hz	125 Hz	250 Hz	500 Hz	1 kHz	2 kHz	4 kHz	8 kHz		
0602R	dB	81	88	92	88	86	82	74	75	dB(A)	90,5
0650R	dB	81	88	92	89	87	83	75	75	dB(A)	91,0
0800R	dB	82	88	93	89	87	83	75	75	dB(A)	91,5
0900R	dB	83	89	93	90	88	84	76	76	dB(A)	92,0
1000R	dB	82	89	93	90	87	84	76	76	dB(A)	92,0
1150R	dB	84	90	94	91	89	85	77	77	dB(A)	93,0
1250R	dB	84	90	94	92	89	86	77	78	dB(A)	93,5
1350R	dB	84	91	95	92	90	86	78	78	dB(A)	94,0
1500R	dB	84	91	95	92	89	86	78	78	dB(A)	94,0
1750R	dB	85	91	95	92	90	86	78	78	dB(A)	94,5
1800R	dB	85	91	95	93	90	87	78	78	dB(A)	94,5
2000R	dB	85	91	96	93	90	87	79	79	dB(A)	95,0
2300R	dB	87	93	97	94	92	88	80	80	dB(A)	96,0
2500R	dB	87	93	97	95	92	89	80	81	dB(A)	96,5
2800R	dB	87	94	98	95	93	89	81	81	dB(A)	97,0
3000R	dB	87	94	98	95	92	89	81	81	dB(A)	97,0
3200R	dB	88	94	98	95	93	89	81	81	dB(A)	97,5
3500R	dB	88	94	98	96	93	90	81	81	dB(A)	97,5
4000R	dB	88	94	99	96	93	90	82	82	dB(A)	98,0

(1) In dB ref=10⁻¹² W, as a guideline. Measured in accordance with ISO 9614-1.

(2) In dB ref=10⁻¹² W, (A) weighting, with an uncertainty of +/-3 dB. Measured in accordance with ISO 9614-1 and certified by Eurovent.

■ Sound pressure level (Lp) - Cooling mode

Measurement conditions: Free field, 10 metres from machine, 1.5 metres above floor level, directivity 2

Note: the sound pressure levels depend on the installation conditions of each system. As such, the levels listed here are given for information only. Only the sound power levels are comparable and certified.

AQUACIAT ^{POWER} ILD Unit + High temperature option/Rated high performance	Sound pressure spectrum ⁽¹⁾									Global sound pressure spectrum ⁽²⁾	
		63 Hz	125 Hz	250 Hz	500 Hz	1 kHz	2 kHz	4 kHz	8 kHz		
0602R	dB	49	56	60	56	54	50	42	43	dB(A)	58,5
0700R	dB	49	56	60	57	55	51	43	43	dB(A)	59,0
0800R	dB	50	56	61	57	55	51	43	43	dB(A)	59,5
0900R	dB	51	57	61	58	56	52	44	44	dB(A)	60,0
1000R	dB	50	57	61	58	55	52	44	44	dB(A)	60,0
1150R	dB	52	58	62	59	57	53	45	45	dB(A)	61,0
1250R	dB	52	58	62	60	57	54	45	46	dB(A)	61,5
1400R	dB	52	59	63	60	58	54	46	46	dB(A)	62,0
1500R	dB	52	59	63	60	57	54	46	46	dB(A)	62,0
1600R	dB	52	59	63	60	57	54	46	46	dB(A)	62,0
1750R	dB	52	59	63	60	57	54	46	46	dB(A)	62,5
2000R	dB	53	59	63	61	58	55	46	46	dB(A)	63,0
2300R	dB	55	61	65	62	60	56	48	48	dB(A)	64,0
2500R	dB	55	61	65	63	60	57	48	49	dB(A)	64,5
2800R	dB	55	62	66	63	61	57	49	49	dB(A)	65,0
3000R	dB	55	62	66	63	60	57	49	49	dB(A)	65,0
3200R	dB	55	62	66	63	60	57	49	49	dB(A)	65,0
3500R	dB	55	62	66	63	60	57	49	49	dB(A)	65,5
4000R	dB	56	62	66	64	61	58	49	49	dB(A)	66,0

(1) In dB ref=2x10⁻⁵ Pa, as a guideline.

(2) In dB ref=2x10⁻⁵ Pa, (A) weighting with an uncertainty of +/-3 dB.

SOUND LEVELS - REVERSIBLE HEAT PUMP

Unit + Very Low Noise option

■ Sound power level (LW) - Cooling mode

AQUACIAT ^{POWER} ILD Unit + Very Low Noise option	Power level spectrum ⁽¹⁾									Global sound power level ⁽²⁾	
		63 Hz	125 Hz	250 Hz	500 Hz	1 kHz	2 kHz	4 kHz	8 kHz		
0602R	dB	76	80	83	85	80	75	69	74	dB(A)	85,0
0700R	dB	77	81	84	86	81	76	70	75	dB(A)	86,0
0800R	dB	77	82	85	86	82	77	71	75	dB(A)	86,5
0900R	dB	78	82	85	87	82	77	71	76	dB(A)	87,0
1000R	dB	78	82	85	87	81	78	71	75	dB(A)	87,0
1150R	dB	79	83	86	88	83	79	72	77	dB(A)	88,0
1250R	dB	79	83	86	88	82	79	72	76	dB(A)	88,0
1400R	dB	80	84	87	89	84	79	73	78	dB(A)	89,0
1500R	dB	80	84	87	89	83	80	73	77	dB(A)	89,0
1600R	dB	80	85	87	89	84	80	73	78	dB(A)	89,5
1750R	dB	81	85	88	90	84	81	74	78	dB(A)	90,0
2000R	dB	81	85	88	90	84	81	74	78	dB(A)	90,0
2300R	dB	82	86	89	91	86	82	75	80	dB(A)	91,0
2500R	dB	82	86	89	91	85	82	75	79	dB(A)	91,0
2800R	dB	83	87	90	92	87	82	76	81	dB(A)	92,0
3000R	dB	83	87	90	92	86	83	76	80	dB(A)	92,0
3200R	dB	83	88	90	92	87	83	76	81	dB(A)	92,5
3500R	dB	84	88	91	93	87	84	77	81	dB(A)	93,0
4000R	dB	84	88	91	93	87	84	77	81	dB(A)	93,0

(1) In dB ref=10⁻¹² W, as a guideline. Measured in accordance with ISO 9614-1.

(2) In dB ref=10⁻¹² W, (A) weighting, with an uncertainty of +/-3 dB. Measured in accordance with ISO 9614-1 and certified by Eurovent.

■ Sound pressure level (Lp) - Cooling mode

Measurement conditions: Free field, 10 metres from machine, 1.5 metres above floor level, directivity 2

Note: the sound pressure levels depend on the installation conditions of each system. As such, the levels listed here are given for information only. Only the sound power levels are comparable and certified.

AQUACIAT ^{POWER} ILD Unit + Very Low Noise option	Sound pressure spectrum ⁽¹⁾									Global sound pressure spectrum ⁽²⁾	
		63 Hz	125 Hz	250 Hz	500 Hz	1 kHz	2 kHz	4 kHz	8 kHz		
0602R	dB	44	48	51	53	48	43	37	42	dB(A)	53,0
0700R	dB	45	49	52	54	49	44	38	43	dB(A)	54,0
0800R	dB	45	50	53	54	50	45	39	43	dB(A)	54,5
0900R	dB	46	50	53	55	50	45	39	44	dB(A)	55,0
1000R	dB	46	50	53	55	49	46	39	43	dB(A)	55,0
1150R	dB	47	51	54	56	51	47	40	45	dB(A)	56,0
1250R	dB	47	51	54	56	50	47	40	44	dB(A)	56,0
1400R	dB	48	52	55	57	52	47	41	46	dB(A)	57,0
1500R	dB	48	52	55	57	51	48	41	45	dB(A)	57,0
1600R	dB	48	52	55	57	52	47	41	46	dB(A)	57,0
1750R	dB	49	53	55	58	52	48	41	46	dB(A)	57,5
2000R	dB	49	53	55	58	52	48	41	46	dB(A)	57,5
2300R	dB	50	54	57	59	54	50	43	48	dB(A)	59,0
2500R	dB	50	54	57	59	53	50	43	47	dB(A)	59,0
2800R	dB	51	55	58	60	55	50	44	49	dB(A)	60,0
3000R	dB	51	55	58	60	54	51	44	48	dB(A)	60,0
3200R	dB	51	55	58	60	55	50	44	49	dB(A)	60,0
3500R	dB	52	56	58	61	55	51	44	49	dB(A)	60,5
4000R	dB	52	56	58	61	55	51	44	49	dB(A)	60,5

(1) In dB ref=2x10⁻⁵ Pa, as a guideline.

(2) In dB ref=2x10⁻⁵ Pa, (A) weighting with an uncertainty of +/-3 dB.

SOUND LEVELS - REVERSIBLE HEAT PUMP

Unit + Ultra Low Noise option

■ Sound power level (LW) - Cooling mode

AQUACIAT ^{POWER} ILD Unit + Ultra Low Noise option	Power level spectrum ⁽¹⁾									Global sound power level ⁽²⁾	
		63 Hz	125 Hz	250 Hz	500 Hz	1 kHz	2 kHz	4 kHz	8 kHz		
0602R	dB	79	80	83	81	78	73	67	74	dB(A)	83,0
0700R	dB	80	82	84	83	79	74	69	75	dB(A)	84,0
0800R	dB	80	82	85	83	80	74	69	76	dB(A)	84,5
0900R	dB	81	83	85	84	80	75	70	76	dB(A)	85,0
1000R	dB	81	82	85	84	80	75	70	76	dB(A)	85,0
1150R	dB	82	84	86	85	81	76	71	77	dB(A)	86,0
1250R	dB	82	83	86	85	81	76	71	77	dB(A)	86,0
1400R	dB	82	84	87	85	81	77	71	78	dB(A)	86,5
1500R	dB	83	84	87	86	82	77	72	78	dB(A)	87,0
1600R	dB	83	85	88	86	83	78	72	79	dB(A)	87,5
1750R	dB	83	85	88	86	82	78	72	79	dB(A)	87,5
2000R	dB	84	85	88	87	83	78	73	79	dB(A)	88,0
2300R	dB	85	87	89	88	84	79	74	80	dB(A)	89,0
2500R	dB	85	86	89	88	84	79	74	80	dB(A)	89,0
2800R	dB	85	87	90	88	84	80	74	81	dB(A)	89,5
3000R	dB	86	87	90	89	85	80	75	81	dB(A)	90,0
3200R	dB	86	88	91	89	86	81	75	82	dB(A)	90,5
3500R	dB	86	88	91	89	85	81	75	82	dB(A)	90,5
4000R	dB	87	88	91	90	86	81	76	82	dB(A)	91,0

(1) In dB ref=10⁻¹² W, as a guideline. Measured in accordance with ISO 9614-1.

(2) In dB ref=10⁻¹² W, (A) weighting, with an uncertainty of +/-3 dB. Measured in accordance with ISO 9614-1 and certified by Eurovent.

■ Sound pressure level (Lp) - Cooling mode

Measurement conditions: Free field, 10 metres from machine, 1.5 metres above floor level, directivity 2

Note: the sound pressure levels depend on the installation conditions of each system. As such, the levels listed here are given for information only. Only the sound power levels are comparable and certified.

AQUACIAT ^{POWER} ILD Unit + Ultra Low Noise option	Sound pressure spectrum ⁽¹⁾									Global sound pressure spectrum ⁽²⁾	
		63 Hz	125 Hz	250 Hz	500 Hz	1 kHz	2 kHz	4 kHz	8 kHz		
0602R	dB	47	48	51	49	46	41	35	42	dB(A)	51,0
0700R	dB	48	50	52	51	47	42	37	43	dB(A)	52,0
0800R	dB	48	50	53	51	48	42	37	44	dB(A)	52,5
0900R	dB	49	51	53	52	48	43	38	44	dB(A)	53,0
1000R	dB	49	50	53	52	48	43	38	44	dB(A)	53,0
1150R	dB	50	52	54	53	49	44	39	45	dB(A)	54,0
1250R	dB	50	51	54	53	49	44	39	45	dB(A)	54,0
1400R	dB	50	52	55	53	49	45	39	46	dB(A)	54,5
1500R	dB	51	52	55	54	50	45	40	46	dB(A)	55,0
1600R	dB	51	53	55	54	50	45	40	46	dB(A)	55,5
1750R	dB	51	52	55	54	50	45	40	46	dB(A)	55,5
2000R	dB	51	53	56	54	50	46	40	47	dB(A)	56,0
2300R	dB	53	55	57	56	52	47	42	48	dB(A)	57,0
2500R	dB	53	54	57	56	52	47	42	48	dB(A)	57,0
2800R	dB	53	55	58	56	52	48	42	49	dB(A)	57,5
3000R	dB	54	55	58	57	53	48	43	49	dB(A)	58,0
3200R	dB	54	56	58	57	53	48	43	49	dB(A)	58,5
3500R	dB	54	55	58	57	53	48	43	49	dB(A)	58,5
4000R	dB	54	56	59	57	53	49	43	50	dB(A)	59,0

(1) In dB ref=2x10⁻⁵ Pa, as a guideline.

(2) In dB ref=2x10⁻⁵ Pa, (A) weighting with an uncertainty of +/-3 dB.

INSTALLATION WATER VOLUME - EXCHANGER WATER FLOW RATE

The Connect Touch control is equipped with anticipation logic making it highly flexible in adjusting operation to parameter drift, particularly on hydraulic systems with low water volumes. By adjusting compressor running times, it prevents short-cycle protection cycles from starting and, in most cases, eliminates the need for a buffer tank.

Note: The minimum volumes of chilled water are calculated for EUROVENT rated conditions:

Cooling mode

- Chilled water temperature = 12 °C/7 °C
- Outdoor air temperature = 35 °C

Heating mode

- Hot water temperature = 40 °C/45 °C
- Outdoor air temperature = 7 °C

This value is applicable for most air conditioning applications (unit with fan coil units).

Note:

For installations running with a low volume of water (assembly with air handling unit) or for industrial processes, the buffer tank is a required component.

AQUACIATPOWER LD		0602R	0650R	0750R	0900R	1100R	1200R	1350R	1400R	1600R
Minimum system water volume, air conditioning application	(litres)	431	468	516	568	676	777	864	949	1039
Minimum system water volume, industrial process application	(litres)	1121	1217	1342	1476	1758	2021	2247	2467	2702
Water type heat exchanger flow rate without hydraulic module Min ⁽¹⁾ /Max ⁽²⁾	(l/s)	2,7 / 17,5	2,7 / 17,5	3,3 / 17,5	2,8 / 17,5	3,4 / 21,8	2,8 / 29,8	3,5 / 35,2	3,3 / 33,8	3,9 / 38,9
Water type heat exchanger flow rate with low-pressure hydraulic module	Single min ⁽³⁾ /Max (l/s)	2,7 / 12,0	2,7 / 12,0	3,3 / 12,0	2,8 / 12,0	3,4 / 14,7	2,8 / 19,3	3,5 / 20,1	3,3 / 19,9	3,9 / 28,2
	Dual min ⁽³⁾ /Max (l/s)	2,7 / 10,5	2,7 / 10,5	3,3 / 12,2	2,8 / 12,2	3,4 / 14,7	2,8 / 19,1	3,5 / 20,0	3,3 / 19,8	3,9 / 23,3
Water type heat exchanger with high-pressure hydraulic module	Single min ⁽³⁾ /Max (l/s)	2,7 / 14,1	2,7 / 14,1	3,3 / 14,1	2,8 / 14,1	3,4 / 16,0	2,8 / 17,5	3,5 / 25,0	3,3 / 24,8	3,9 / 25,4
	Dual min ⁽³⁾ /Max (l/s)	2,7 / 13,7	2,7 / 13,7	3,3 / 13,7	2,8 / 13,7	3,4 / 16,6	2,8 / 18,5	3,5 / 24,4	3,3 / 24,1	3,9 / 24,9

AQUACIATPOWER LD		1750R	1800R	2000R	2200R	2400R	2650R	2800R	2950R	3200R	3500R
Minimum system water volume, air conditioning application	(litres)	1126	1209	1381	1542	1694	1816	1955	2017	2204	2359
Minimum system water volume, industrial process application	(litres)	2928	3144	3590	4009	4405	4723	5083	5245	5730	6132
Water type heat exchanger flow rate without hydraulic module Min ⁽¹⁾ /Max ⁽²⁾	(l/s)	4,2 / 40,4	4,7 / 41,6	5,2 / 43,4	6,1 / 57,3	5,8 / 57,3	6,3 / 57,3	6 / 62,7	6,3 / 62,7	5,8 / 62,7	6,2 / 62,7
Water type heat exchanger flow rate with low-pressure hydraulic module	Single min ⁽³⁾ /Max (l/s)	4,2 / 28,8	4,7 / 29,4	5,2 / 27,0	- / -	- / -	- / -	- / -	- / -	- / -	- / -
	Dual min ⁽³⁾ /Max (l/s)	4,2 / 27,8	4,7 / 28,5	5,2 / 27,0	- / -	- / -	- / -	- / -	- / -	- / -	- / -
Water type heat exchanger with high-pressure hydraulic module	Single min ⁽³⁾ /Max (l/s)	4,2 / 28,5	4,7 / 28,6	5,2 / 28,8	6,1 / 42,4	5,8 / 42,4	6,3 / 42,4	6 / 50,4	6,3 / 50,4	5,8 / 50,4	6,2 / 50,4
	Dual min ⁽³⁾ /Max (l/s)	4,2 / 28,2	4,7 / 28,4	5,2 / 33,7	6,1 / 42,4	5,8 / 42,4	6,3 / 42,4	6 / 50,4	6,3 / 50,4	5,8 / 50,4	6,2 / 50,4

(1) Minimum flow rate for maximum permitted water temperature difference conditions (10° C)

(2) Maximum flow rate for a pressure drop of 100 kPa in the plate heat exchanger

(3) Minimum factory flow rate setting according to the type of pump

INSTALLATION WATER VOLUME - EXCHANGER WATER FLOW RATE

AQUACIATPOWER ILD		0602R	0700R	0800R	0900R	1000R	1150R	1250R	1400R	1500R	1600R
Minimum system water volume, air conditioning application - cooling	(litres)	388	425	488	550	588	700	763	863	900	975
Minimum system water volume, air conditioning application - heating	(litres)	1360	1520	1840	2000	2080	2480	2640	2960	3120	3400
Minimum system water volume, industrial process application	(litres)	1008	1105	1268	1430	1528	1820	1983	2243	2340	2535
Water type heat exchanger flow rate without hydraulic module	Min ⁽¹⁾	2,7 /	2,7 /	2,8 /	3,4 /	3,4 /	3,5 /	4,2 /	4,2 /	4,2 /	4,2 /
	Max ⁽²⁾	18	18	18	22	22	35	40	40	40	40
Water type heat exchanger flow rate with low-pressure hydraulic module	Single min ⁽³⁾ /Max (l/s)	2,7 / 12,0	2,7 / 12,0	2,8 / 13,6	3,4 / 14,7	3,4 / 14,7	3,5 / 20,1	4,2 / 28,8	4,2 / 28,8	4,2 / 28,8	4,2 / 28,8
	Dual min ⁽³⁾ /Max (l/s)	2,7 / 10,5	2,7 / 13,2	2,8 / 13,9	3,4 / 14,7	3,4 / 14,7	3,5 / 20,0	4,2 / 27,8	4,2 / 27,8	4,2 / 27,8	4,2 / 27,8
Water type heat exchanger with high-pressure hydraulic module	Single min ⁽³⁾ /Max (l/s)	2,7 / 14,1	2,7 / 14,1	2,8 / 15,2	3,4 / 16,0	3,4 / 16,0	3,5 / 25,0	4,2 / 25,5	4,2 / 25,5	4,2 / 25,5	4,2 / 28,5
	Dual min ⁽³⁾ /Max (l/s)	2,7 / 13,7	2,7 / 13,7	2,8 / 15,6	3,4 / 16,6	3,4 / 16,6	3,5 / 24,4	4,2 / 25,0	4,2 / 28,2	4,2 / 28,2	4,2 / 28,2

AQUACIATPOWER ILD		1750R	2000R	2300R	2500R	2800R	3000R	3200R	3500R	4000R
Minimum system water volume, air conditioning application - cooling	(litres)	1050	1213	1400	1525	1725	1800	1950	2100	2425
Minimum system water volume, air conditioning application - heating	(litres)	3600	4160	4960	5280	5920	6240	6800	7200	8320
Minimum system water volume, industrial process application	(litres)	2730	3153	3640	3965	4485	4680	5070	5460	6305
Flow rate of water type heat exchanger without hydraulic module	Min ⁽¹⁾	4,7 /	5,2 /	7 /	8,4 /	8,4 /	8,4 /	8,4 /	9,4 /	10,4 /
	Max ⁽²⁾	42	43	70,4	80,8	80,8	80,8	80,8	83,2	86,8
Water type heat exchanger flow rate with low-pressure hydraulic module	Single min ⁽³⁾ /Max (l/s)	4,7 / 29,7	5,2 / 30,1	- / -	- / -	- / -	- / -	- / -	- / -	- / -
	Dual min ⁽³⁾ /Max (l/s)	4,7 / 26,8	5,2 / 29,3	- / -	- / -	- / -	- / -	- / -	- / -	- / -
Water type heat exchanger with high-pressure hydraulic module	Single min ⁽³⁾ /Max (l/s)	4,7 / 28,6	5,2 / 34,9	7 / 50,0	8,4 / 51,0	8,4 / 51,0	8,4 / 51,0	8,4 / 51,0	9,4 / 57,2	10,4 / 69,8
	Dual min ⁽³⁾ /Max (l/s)	4,7 / 33,3	5,2 / 33,7	7 / 48,8	8,4 / 50,0	8,4 / 56,4	8,4 / 56,4	8,4 / 56,4	9,4 / 66,6	10,4 / 67,4

(1) Minimum flow rate for maximum permitted water temperature difference conditions (10° C)

(2) Maximum flow rate for a pressure drop of 100 kPa in the plate heat exchanger

(3) Minimum factory flow rate setting according to the type of pump

OPERATING RANGE

AQUACIAT^{POWER} devices have a broad field of application, enabling them to meet a range of heating and cooling requirements in the most varied of climates.

Multi-climate:

Cooling mode from -20 °C to +44 °C (option +48 °C)

The **AQUACIAT^{POWER}** is equipped as standard with all the management devices and algorithms to enable all-season operation in all climates. The **AQUACIAT^{POWER}** equipped with optional all-season operation and/or variable-speed fans is able to operate in conditions ranging from the heat of the Mediterranean basin to the cold of Scandinavia, the humid Atlantic coast to the dry climate of Central Europe.

Heating mode from -10 °C to +35 °C

The design of the **AQUACIAT^{POWER}** makes it suitable for the majority of heating and air conditioning applications, regardless of the climate. Water heating to +45 °C is guaranteed, even for outdoor temperatures of -10 °C.

Multi-application: air conditioning, industrial processes

The **AQUACIAT^{POWER}** can be used for all traditional air conditioning applications in sectors as varied as collective housing, hotels, shopping centres and offices.

LD 602R - 3500R units

Operating range
Options: Rated high performance or Extended application range

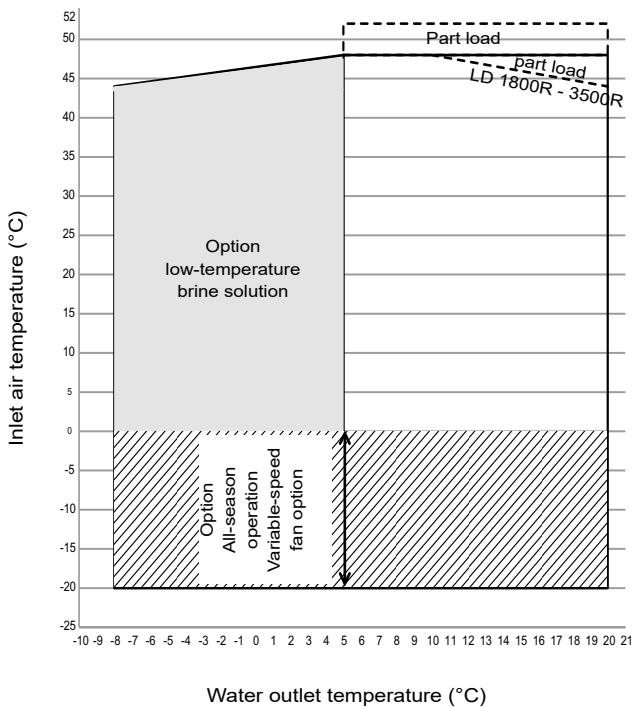

Operating range
Standard unit Basic version VLN/ULN acoustic version

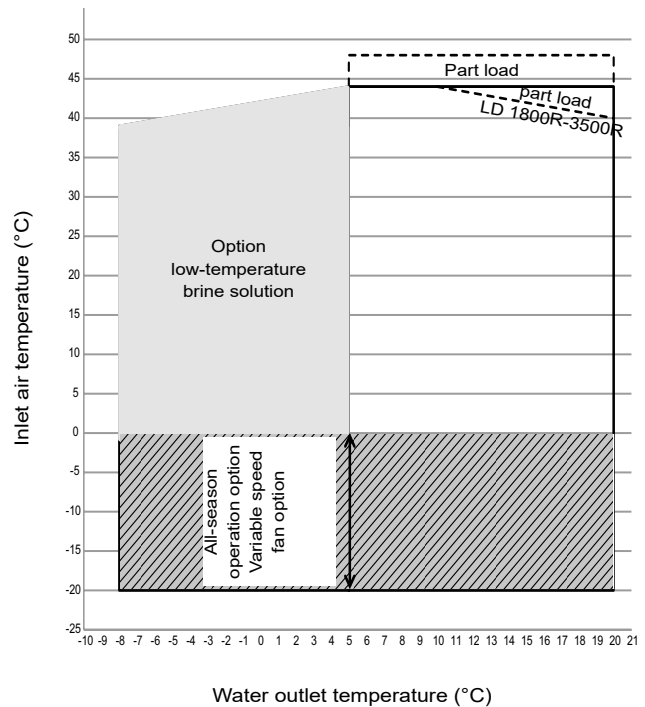

1. Water type heat exchanger $\Delta T = 5K$
2. The water type heat exchanger is protected against frost down to -20 °C (with Water exchanger frost protection option or water type heat exchanger and hydraulic module frost protection option (if present) or water loop protected by antifreeze solution for outdoor temperatures < 0 °C)
3. These ranges are guidelines only. The operating range must be checked with the Selection software.

Key

- Full load
- All-season operation option or variable-speed fans option for units LD 602 to 1400 (see note 2)
- Part load
- Extension of the operating range for units with low-temperature brine solution option

OPERATING RANGE

ILD 602R - 2000R units

Cooling mode ❄️

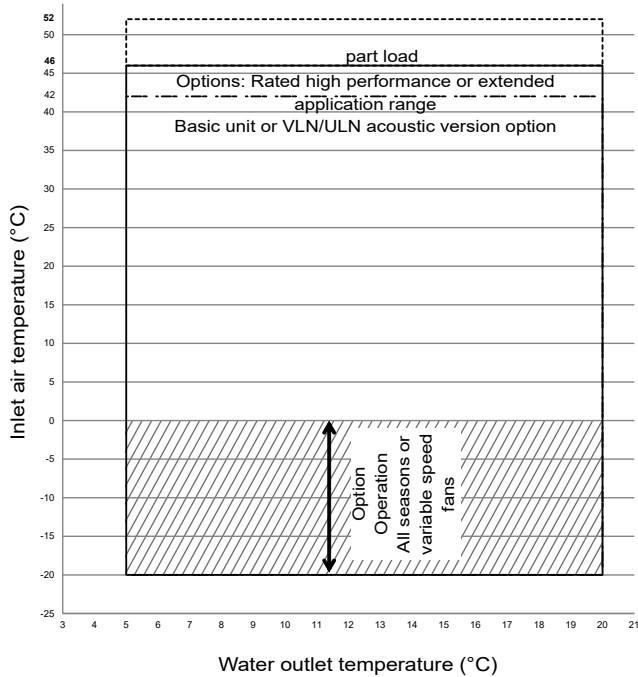

Heating mode ☀️

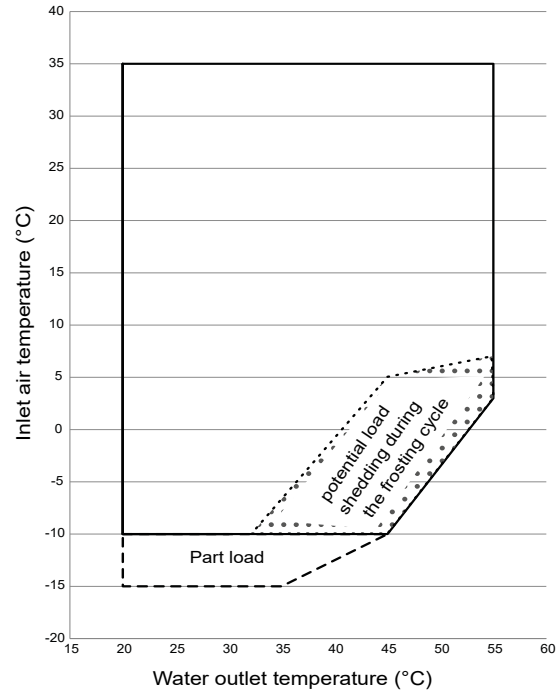

- Full load operating range for AQUACIATPOWERILD units with Rated High performance or Extended application range options
- Extended operating range in cooling mode: ILD unit with Winter operation option for outdoor air temperatures down to -20 °C. The water type heat exchanger must be protected against freezing.
- Part load or potential load shedding during the frosting cycle depending on the humidity conditions. Refer to the manufacturer's electronic catalogue.
- Heating mode: Part load at inlet air temperature between -10 and -15 °C
- Cooling mode: Part load above 46 °C of inlet air temperature.
- Part load operation outside of an inlet air temperature of 42 °C for Basic ILD units or units with the Low noise level option

For operation in pure water at an inlet air temperature below 0 °C, the frost protection option must be provided

HYDRAULIC SPECIFICATIONS

■ Water pressure drop in the evaporator

Data applicable for pure water at 20 °C.

LD 602R - 1400R

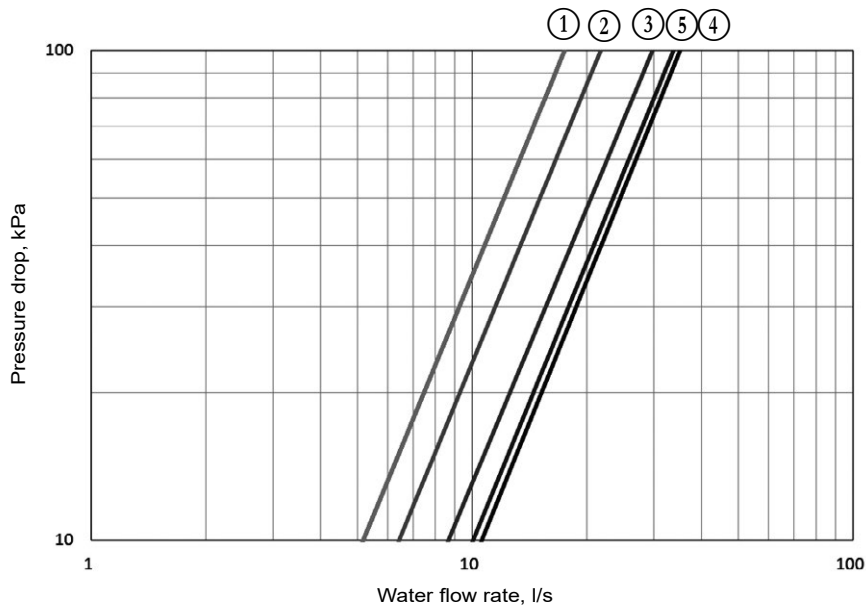

- ① LD 602R - 900R
- ② LD 1100R
- ③ LD 1200R
- ④ LD 1350R
- ⑤ LD 1400R

LD 1600R - 3500R

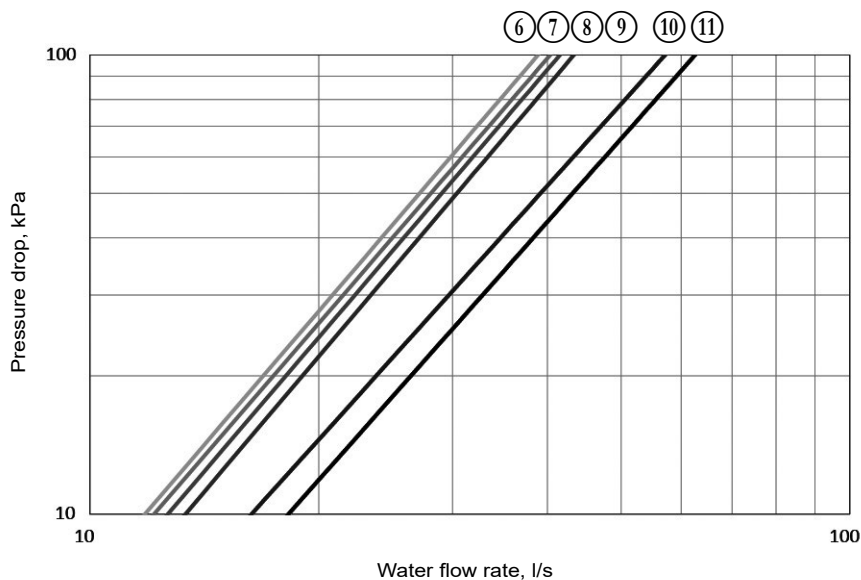

- ⑥ LD 1600R
- ⑦ LD 1750R
- ⑧ LD 1800R
- ⑨ LD 2000R
- ⑩ LD 2200R - 2650R
- ⑪ LD 2800R - 3500R

HYDRAULIC SPECIFICATIONS

ILD 602R-1400R

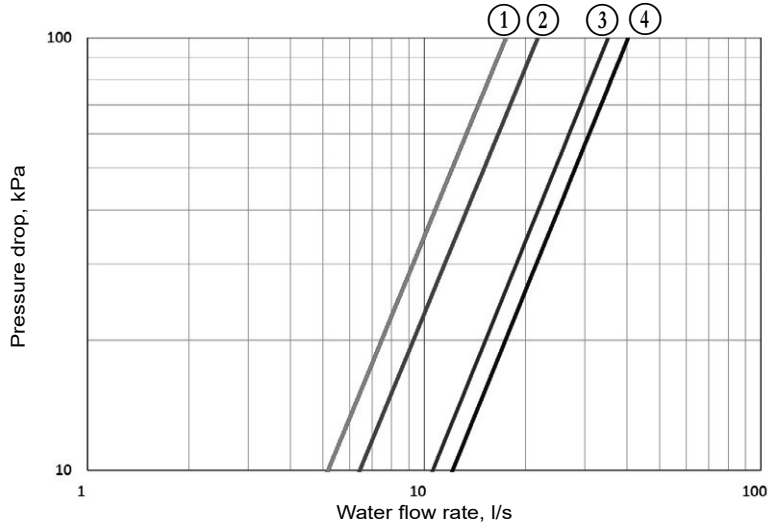

- ① ILD 602R - 800R
- ② ILD 900R - 1000R
- ③ ILD 1150R - 1250R
- ④ ILD 1400R

ILD 1500R-2000R

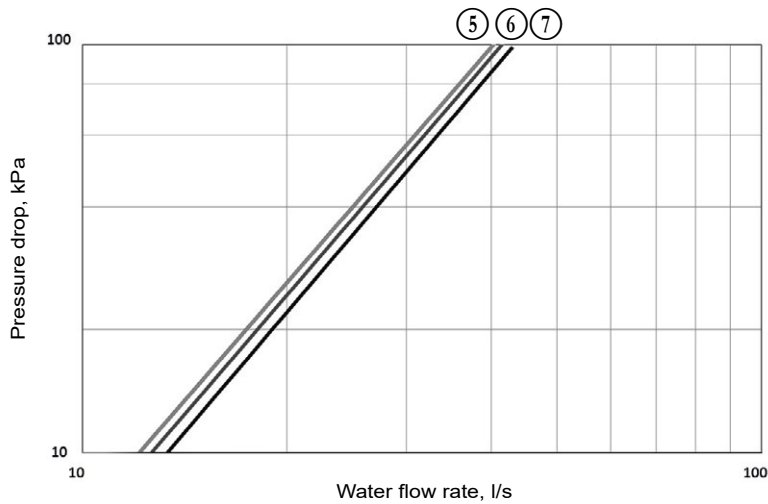

- ⑤ ILD 1500R - 1600R
- ⑥ ILD 1750R
- ⑦ ILD 2000R

ILD 2300R - 4000R

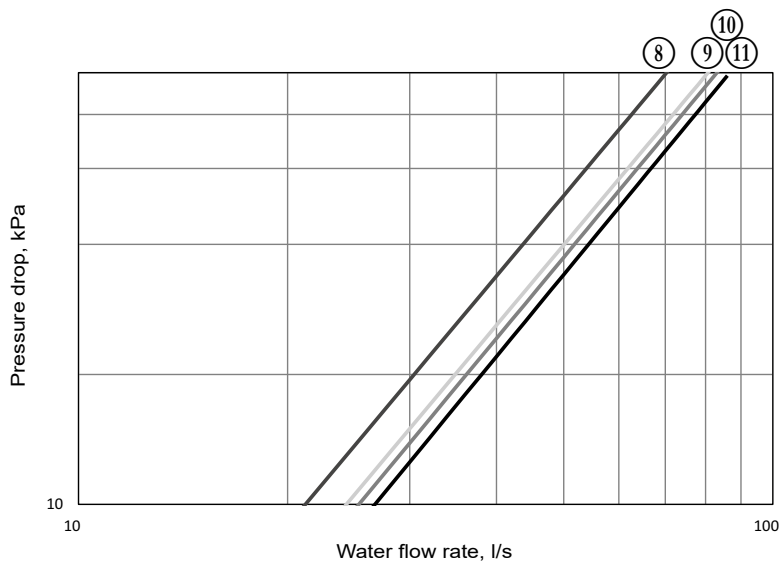

- ⑧ ILD2300R
- ⑨ ILD2500R - 3200R
- ⑩ ILD3500R
- ⑪ ILD4000R

HYDRAULIC SPECIFICATIONS

■ Water pressure drop in the filter

Screen filter (800 µm)

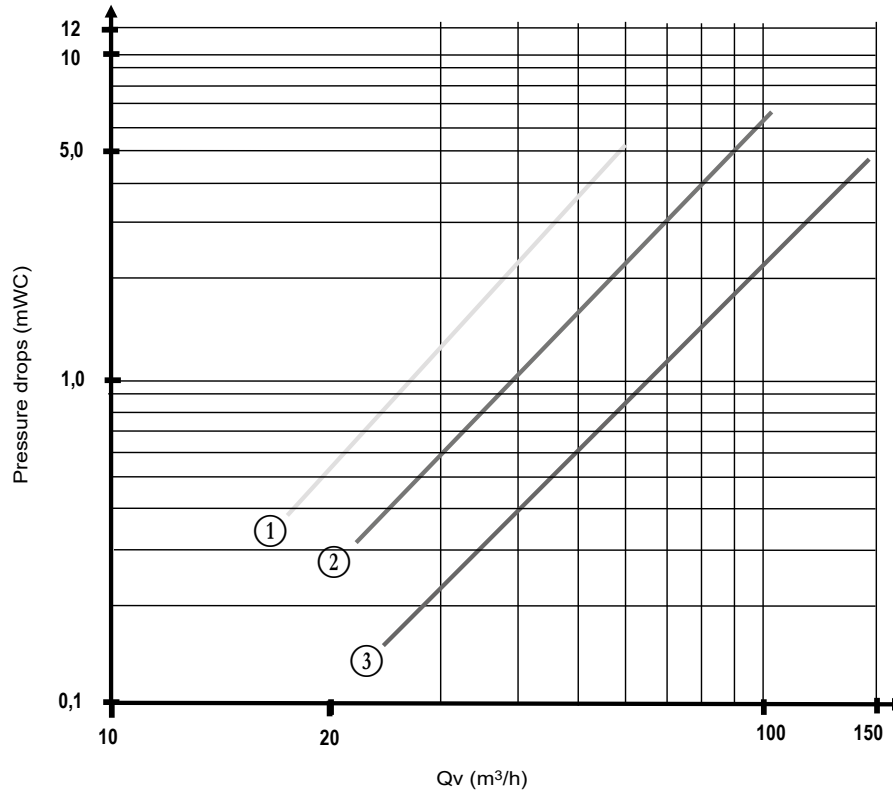

- ① LD 602R - 650R and ILD 602R - 700R (DN80 filter)
- ② LD 750R - 1200R and ILD 800R - 1250R (DN100 filter)
- ③ LD 1350R - 3500R and ILD 1400R - 2000R (DN125 filter)

HYDRAULIC SPECIFICATIONS

■ Available static system pressure

Data applicable for:

- Pure water at 20 °C
- Refer to the section "Exchanger water flow rate" for the minimum and maximum water flow rate values
- If a brine solution is used, the maximum water flow rate is reduced

■ LD high pressure pumps (fixed speed or variable speed)

Single pumps

Sizes 602R - 1600R

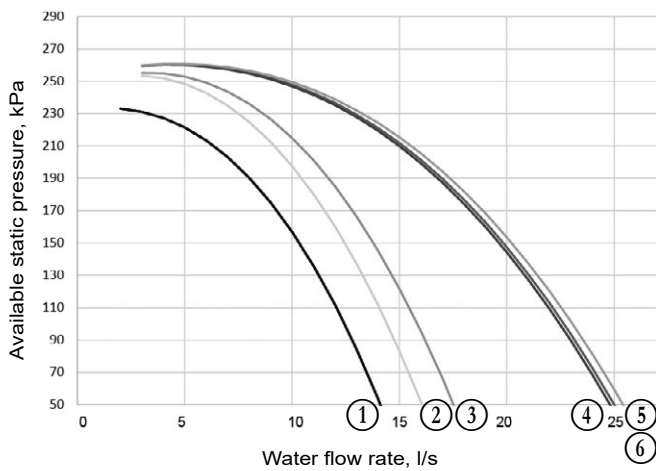

- ① LD 602R - 900R
- ② LD 1100R
- ③ LD 1200R
- ④ LD 1350R
- ⑤ LD 1400R
- ⑥ LD 1600R

Sizes 2200R - 3500R

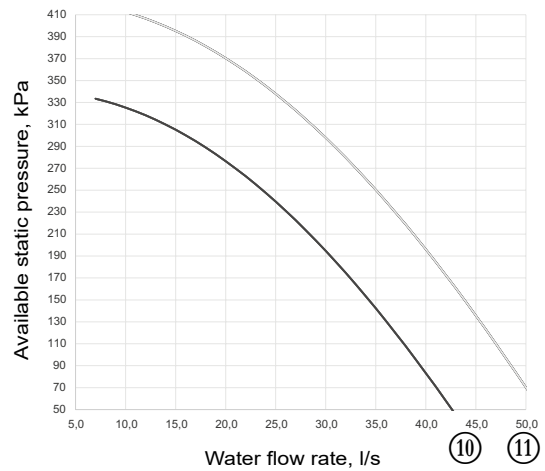

- ⑩ LD 2200R - 2650R
- ⑪ LD 2800R - 3500R

Sizes 1750R - 2000R

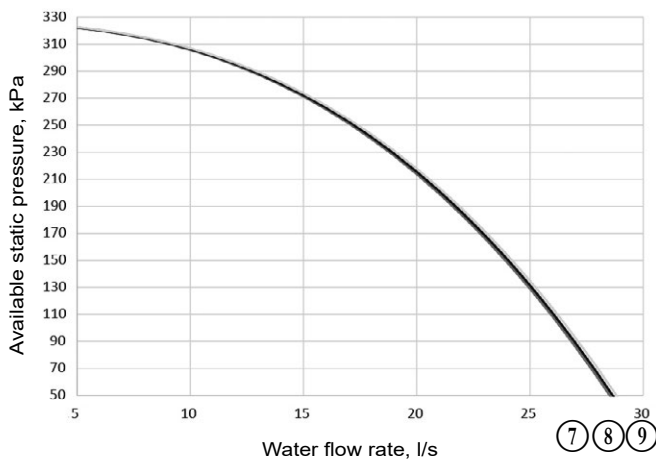

- ⑦ LD 1750R
- ⑧ LD 1800R
- ⑨ LD 2000R

HYDRAULIC SPECIFICATIONS

Dual pumps

Sizes 602R - 1600R

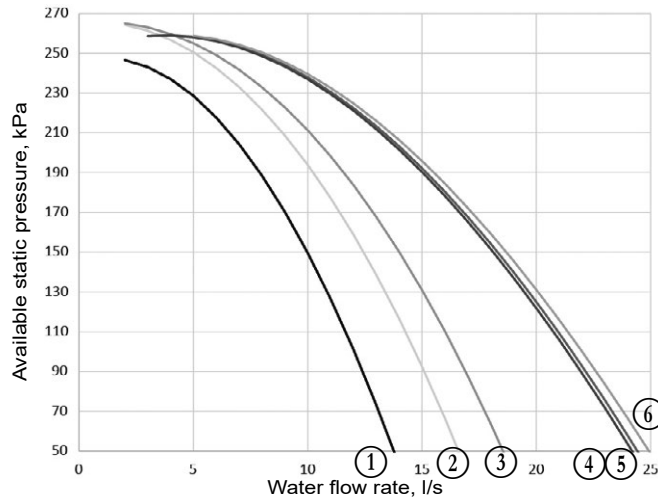

- ① LD 602R - 900R
- ② LD 1100R
- ③ LD 1200R
- ④ LD 1350R
- ⑤ LD 1400R
- ⑥ LD 1600R

Sizes 1750R - 2000R

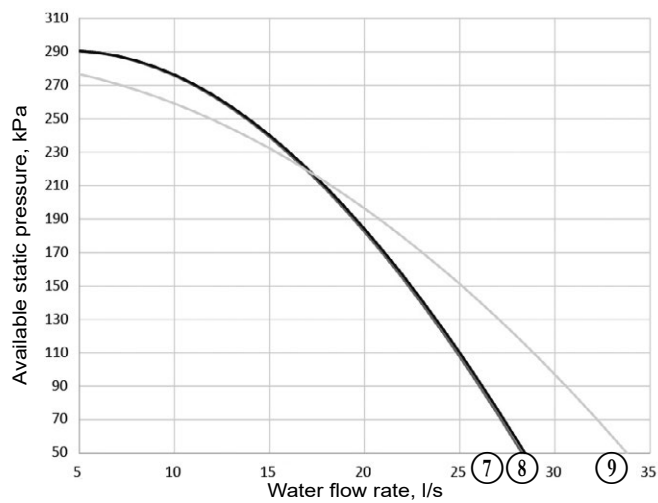

- ⑦ LD 1750R
- ⑧ LD 1800R
- ⑨ LD 2000R

Sizes 2200 - 3500R

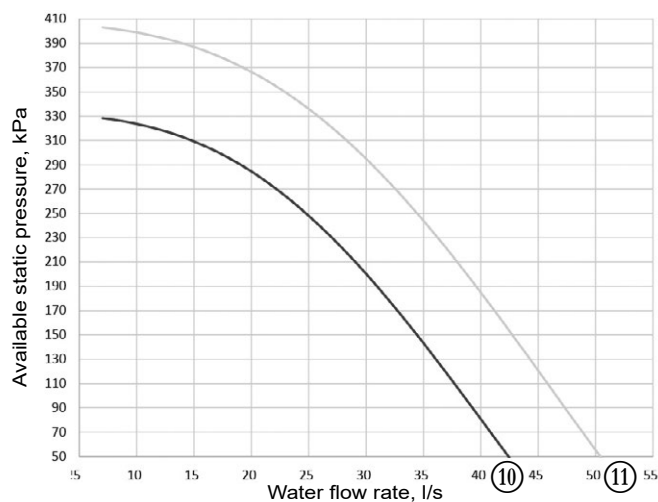

- ⑩ LD 2200R - 2650R
- ⑪ LD 2800R - 3500R

HYDRAULIC SPECIFICATIONS

■ Low pressure pumps (fixed speed)

Single pumps

Sizes 602R - 1400R

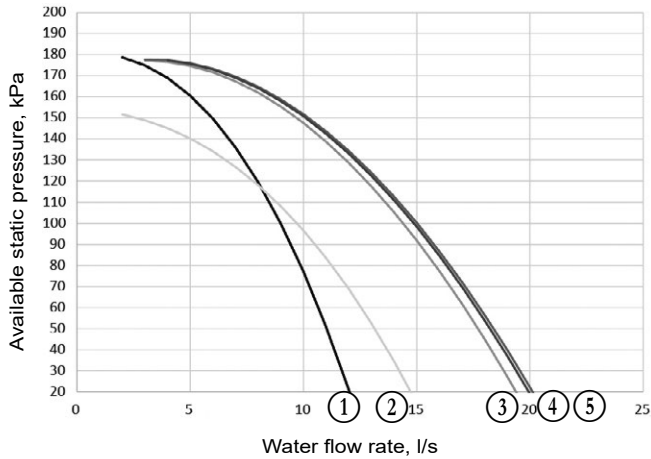

- ① LD 602R - 900R
- ② LD 1100R
- ③ LD 1200R
- ④ LD 1350R
- ⑤ LD 1400R

Sizes 1600R - 2000R

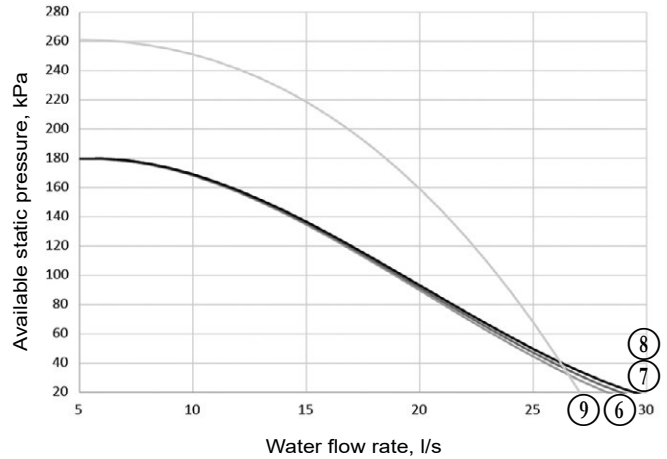

- ⑥ LD 1600R
- ⑦ LD 1750R
- ⑧ LD 1800R
- ⑨ LD 2000R

Dual pumps

Sizes 602R - 1600R

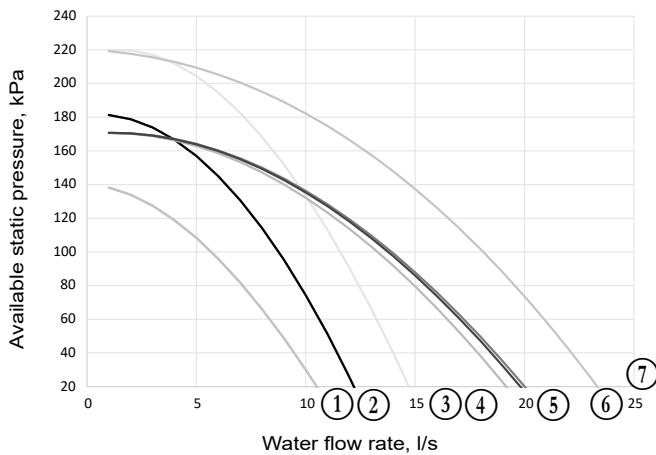

- ① LD 602R - 650R
- ② LD 750R - 900R
- ③ LD 1100R
- ④ LD 1200R
- ⑤ LD 1350R
- ⑥ LD 1400R
- ⑦ LD 1600R

Sizes 1750R - 2000R

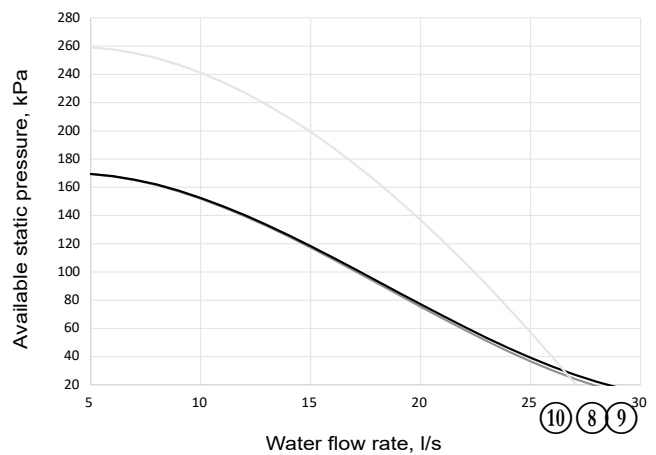

- ⑧ LD 1750R
- ⑨ LD 1800R
- ⑩ LD 2000R

HYDRAULIC SPECIFICATIONS

■ Available static system pressure

Data applicable for:

- Pure water at 20 °C
- Refer to the section "Exchanger water flow rate" for the minimum and maximum water flow rate values
- If a brine solution is used, the maximum water flow rate is reduced

■ ILD high pressure pumps (fixed speed or variable speed)

Single pumps

Sizes 602R - 1000R

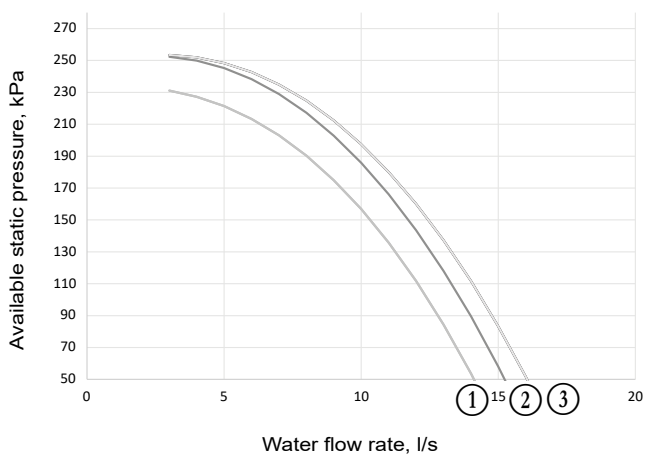

- ① ILD 602R - 700R
- ② ILD 800R
- ③ ILD 900R - 1000R

Sizes 1150R - 2000R

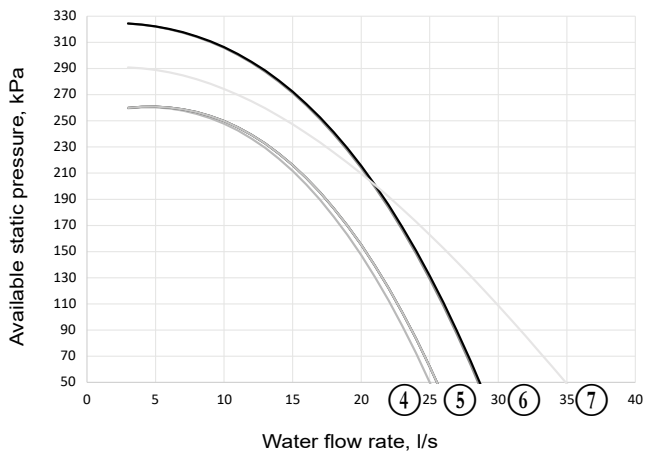

- ④ ILD 1150R
- ⑤ ILD 1250R - 1500R
- ⑥ ILD 1600R - 1750R
- ⑦ ILD 2000R

Sizes 2300R - 4000R

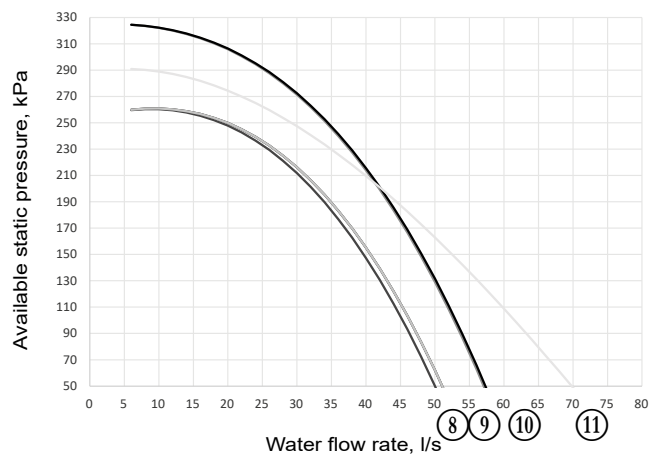

- ⑧ ILD 2300R
- ⑨ ILD 2500R - 3000R
- ⑩ ILD 3200R - 3500R
- ⑪ ILD 4000R

HYDRAULIC SPECIFICATIONS

Dual pumps

Sizes 602R - 1000R

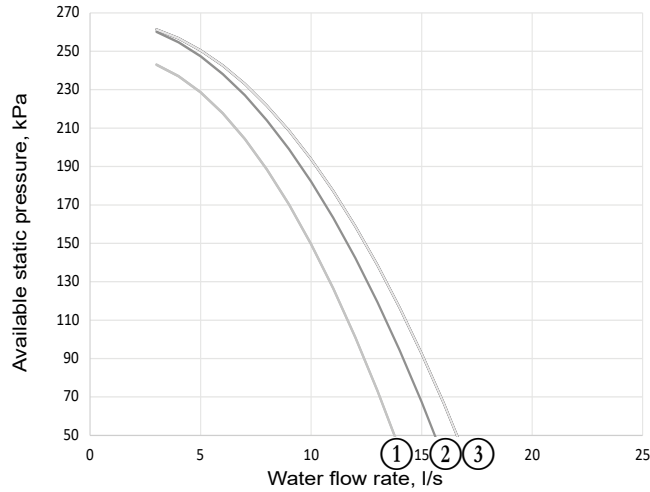

- ① ILD 602R - 700R
- ② ILD 800R
- ③ ILD 900R - 1000R

Sizes 1150R - 2000R

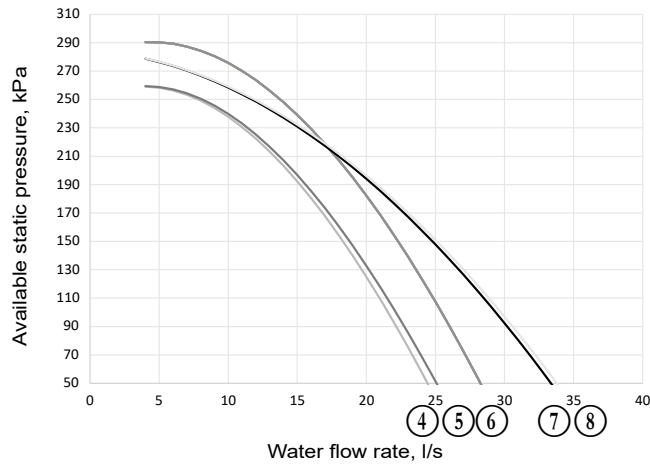

- ④ ILD 1150R
- ⑤ ILD 1250R
- ⑥ ILD 1400R
- ⑦ ILD 1500R - 1600R
- ⑧ ILD 1750R - 2000R

Sizes 2300R - 4000R

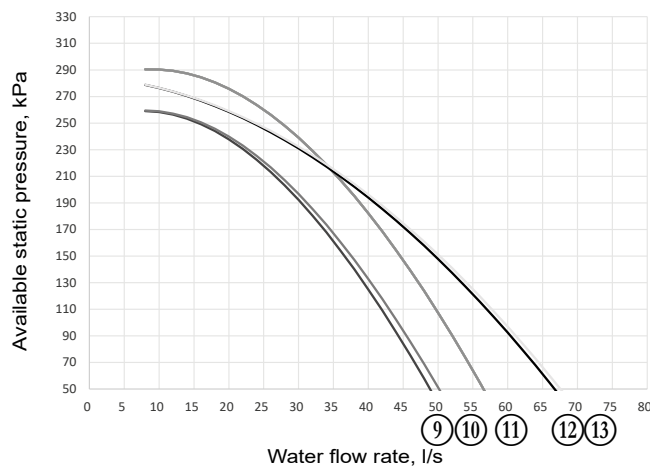

- ⑨ ILD 2300R
- ⑩ ILD 2500R
- ⑪ ILD 2800R
- ⑫ ILD 3000R - 3200R
- ⑬ ILD 3500R - 4000R

HYDRAULIC SPECIFICATIONS

■ ILD low-pressure pumps (fixed-speed)

Single pumps

Sizes 602R - 1000R

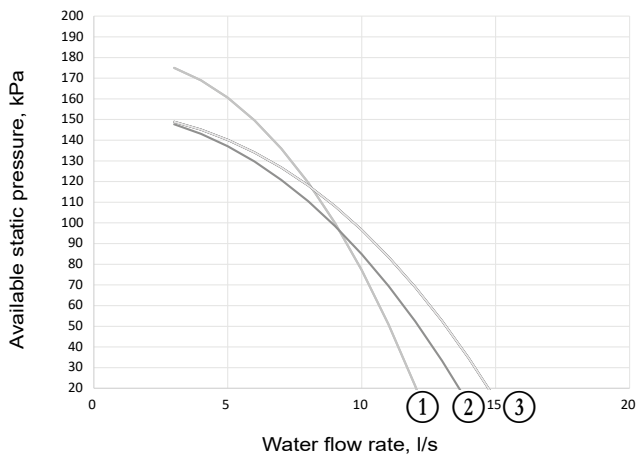

- ① ILD 602R - 700R
- ② ILD 800R
- ③ ILD 900R - 1000R

Sizes 1150R - 2000R

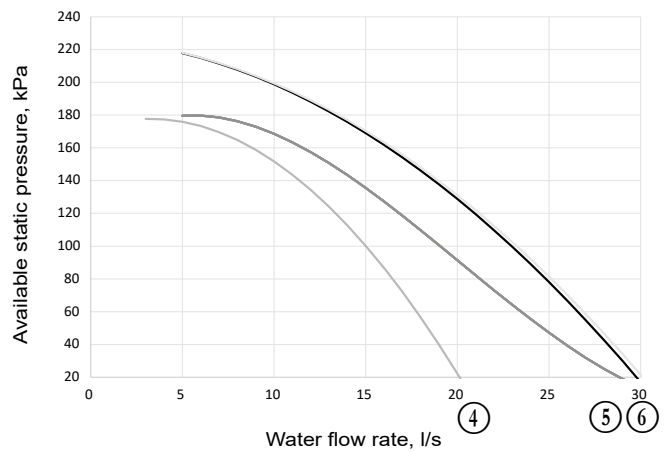

- ④ ILD 1150R
- ⑤ ILD 1250R - 1600R
- ⑥ ILD 1750R - 2000R

Dual pumps

Sizes 602R - 1000R

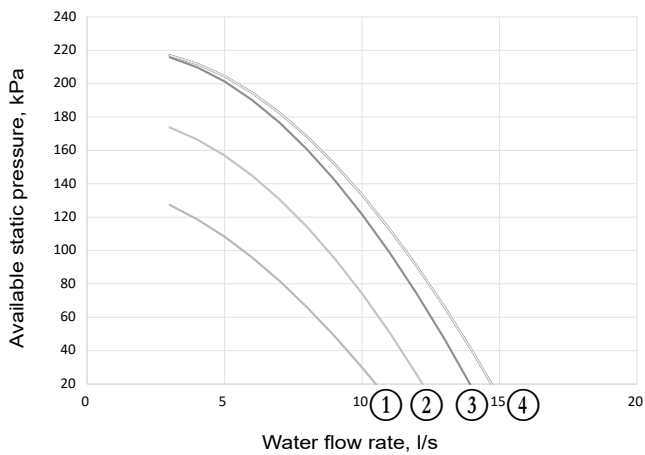

- ① ILD 602R
- ② ILD 700R
- ③ ILD 800R
- ④ ILD 900R - 1000R

Sizes 1150R - 2000R

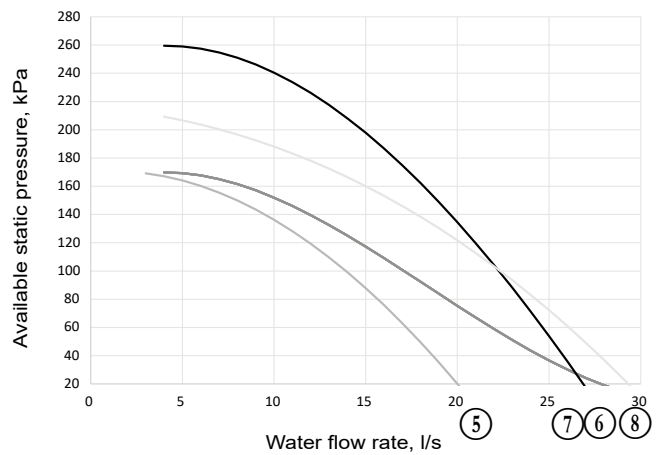

- ⑤ ILD 1150R
- ⑥ ILD 1250R - 1600R
- ⑦ ILD 1750R
- ⑧ ILD 2000R

DIMENSIONS

■ AQUACIAT^{POWER} LD 602R to 1100R/ILD 602R to 1000R Without buffer tank

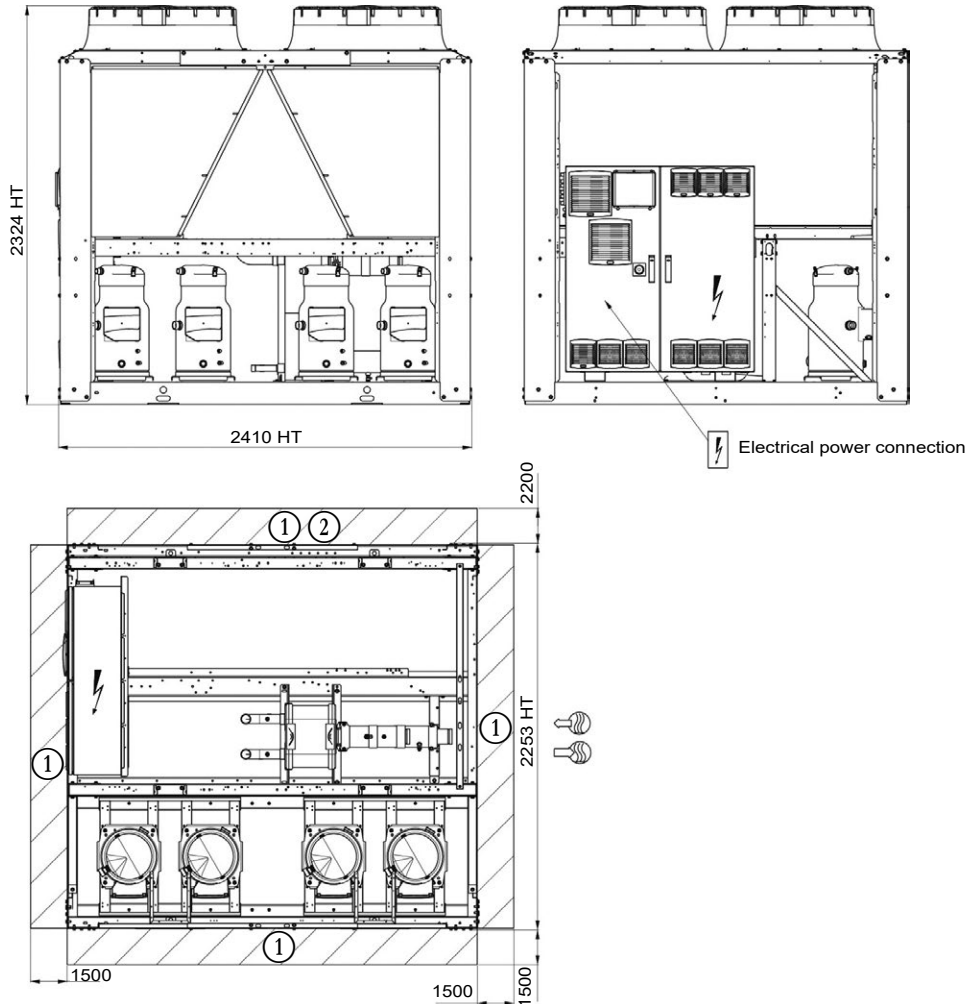

Key

All dimensions in mm

- ① Clearance required for maintenance and air flow
- ② Clearance recommended for coil removal
- Water inlet
- Water outlet
- Air outlet, do not obstruct
- Electrical cabinet

Notes:

Non-contractual drawings.

When designing a system, refer to the certified dimensional drawings provided with the unit or available on request.

Please refer to the certified dimensional drawings for the positioning of the fixing points, weight distribution points and centre of gravity coordinates.

DIMENSIONS

■ AQUACIAT^{POWER} LD 602R to 1100R/ILD 602R to 1000R With buffer tank

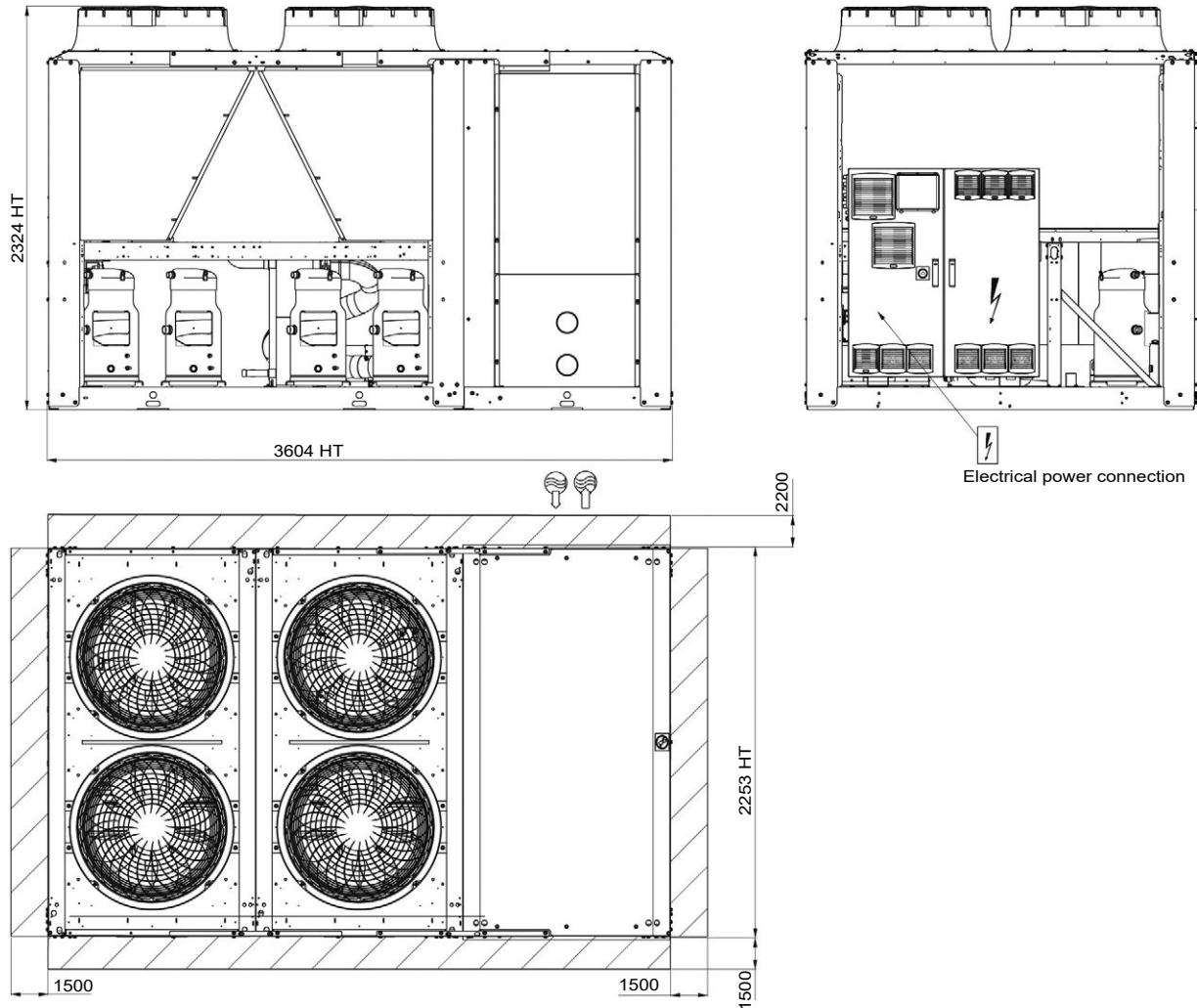

Key

All dimensions in mm

- ① Clearance required for maintenance and air flow
- ② Clearance recommended for coil removal
- Water inlet
- Water outlet
- Air outlet, do not obstruct
- Electrical cabinet

Notes:

Non-contractual drawings.

When designing a system, refer to the certified dimensional drawings provided with the unit or available on request.

Please refer to the certified dimensional drawings for the positioning of the fixing points, weight distribution points and centre of gravity coordinates.

DIMENSIONS

■ AQUACIAT^{POWER} LD 1200R to 1600R/ILD 1150R to 1500R Without buffer tank

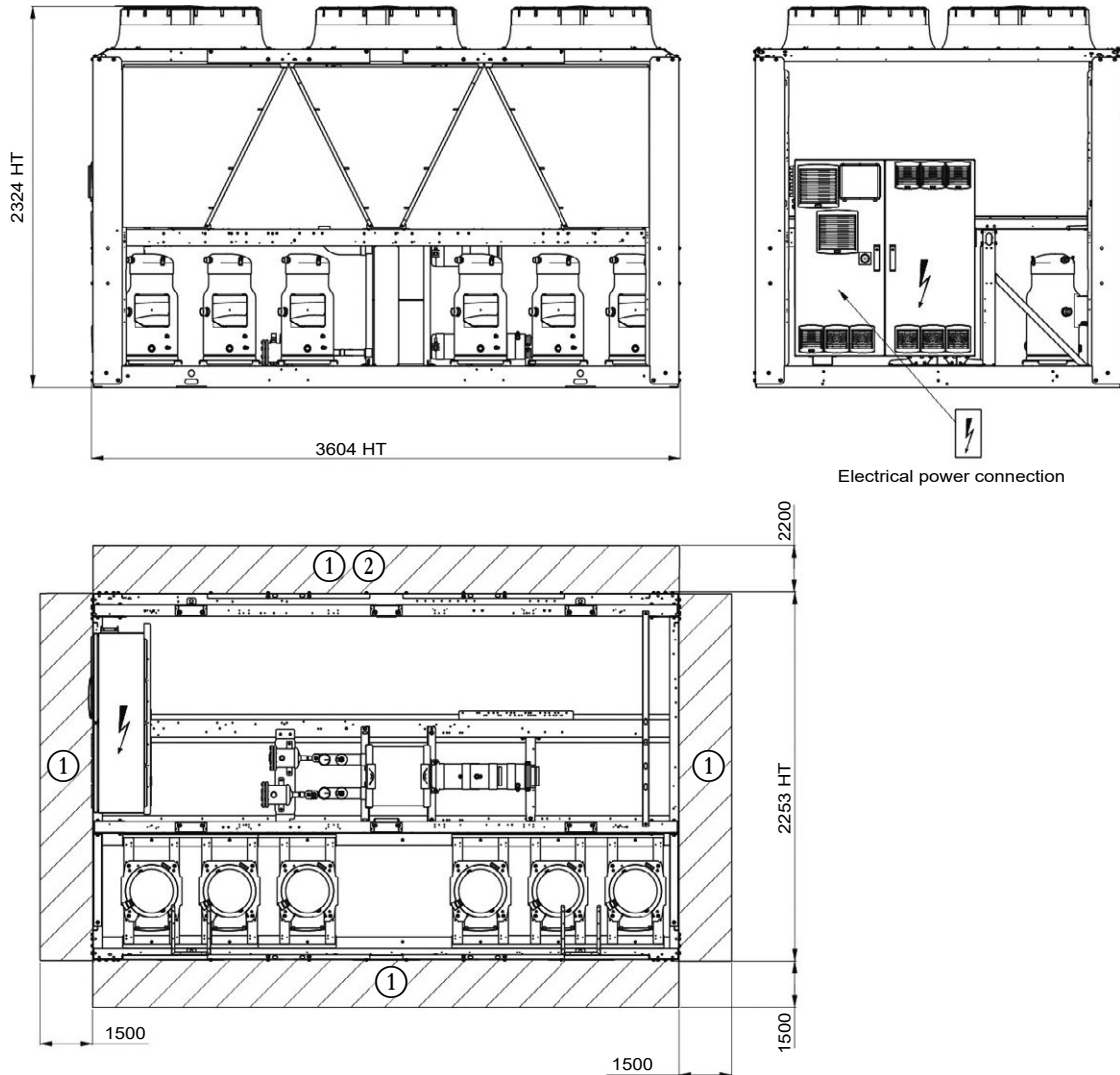

Electrical power connection

Key

All dimensions in mm

- ① Clearance required for maintenance and air flow
- ② Clearance recommended for coil removal
- Water inlet
- Water outlet
- Air outlet, do not obstruct
- Electrical cabinet

Notes:

Non-contractual drawings.

When designing a system, refer to the certified dimensional drawings provided with the unit or available on request.

Please refer to the certified dimensional drawings for the positioning of the fixing points, weight distribution points and centre of gravity coordinates.

DIMENSIONS

■ AQUACIAT^{POWER} LD 1200R to 1600R/ILD 1150R to 1500R With buffer tank

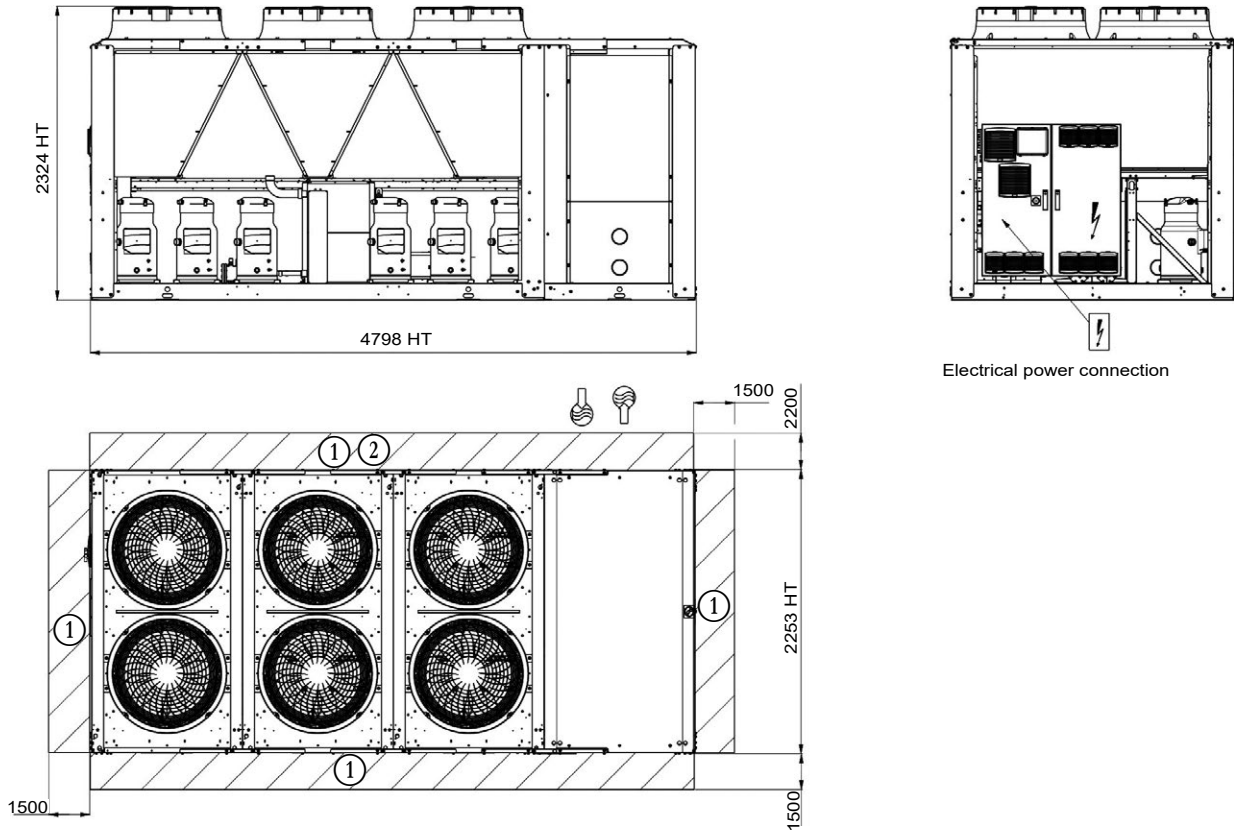

Key

All dimensions in mm

- ① Clearance required for maintenance and air flow
- ② Clearance recommended for coil removal
- Water inlet
- Water outlet
- Air outlet, do not obstruct
- Electrical cabinet

Notes:

Non-contractual drawings.

When designing a system, refer to the certified dimensional drawings provided with the unit or available on request.

Please refer to the certified dimensional drawings for the positioning of the fixing points, weight distribution points and centre of gravity coordinates.

DIMENSIONS

■ **AQUACIAT^{POWER} LD 1750R to 2000R/ILD 1600R to 2000R Without buffer tank**

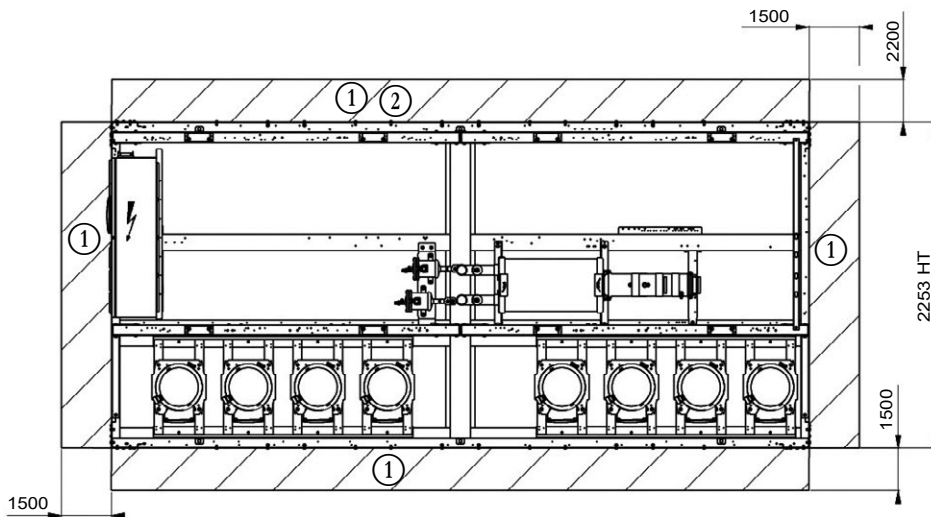
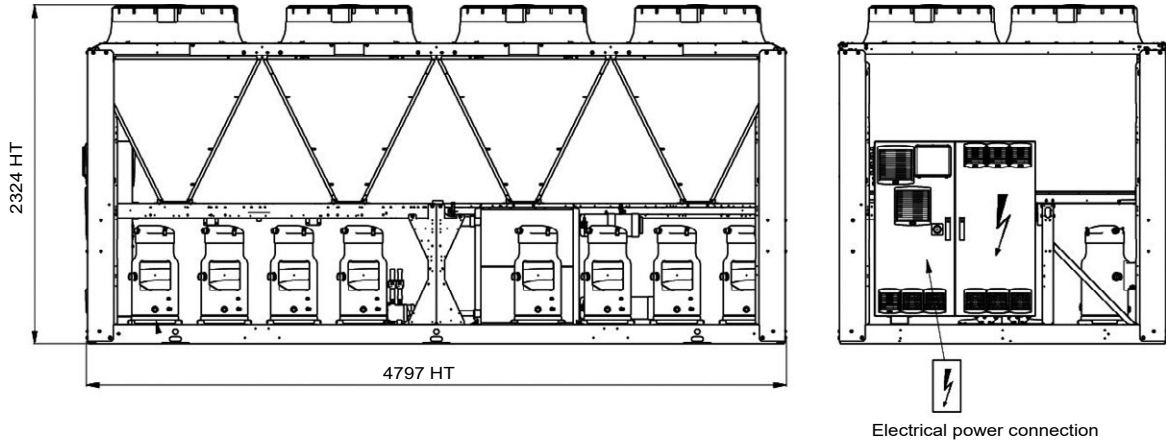

Key

All dimensions in mm

- ① Clearance required for maintenance and air flow
- ② Clearance recommended for coil removal
- Water inlet
- Water outlet
- Air outlet, do not obstruct
- Electrical cabinet

Notes:

Non-contractual drawings.

When designing a system, refer to the certified dimensional drawings provided with the unit or available on request.

Please refer to the certified dimensional drawings for the positioning of the fixing points, weight distribution points and centre of gravity coordinates.

DIMENSIONS

■ AQUACIAT^{POWER} LD 1750R to 2000R/ILD 1600R to 2000R With buffer tank

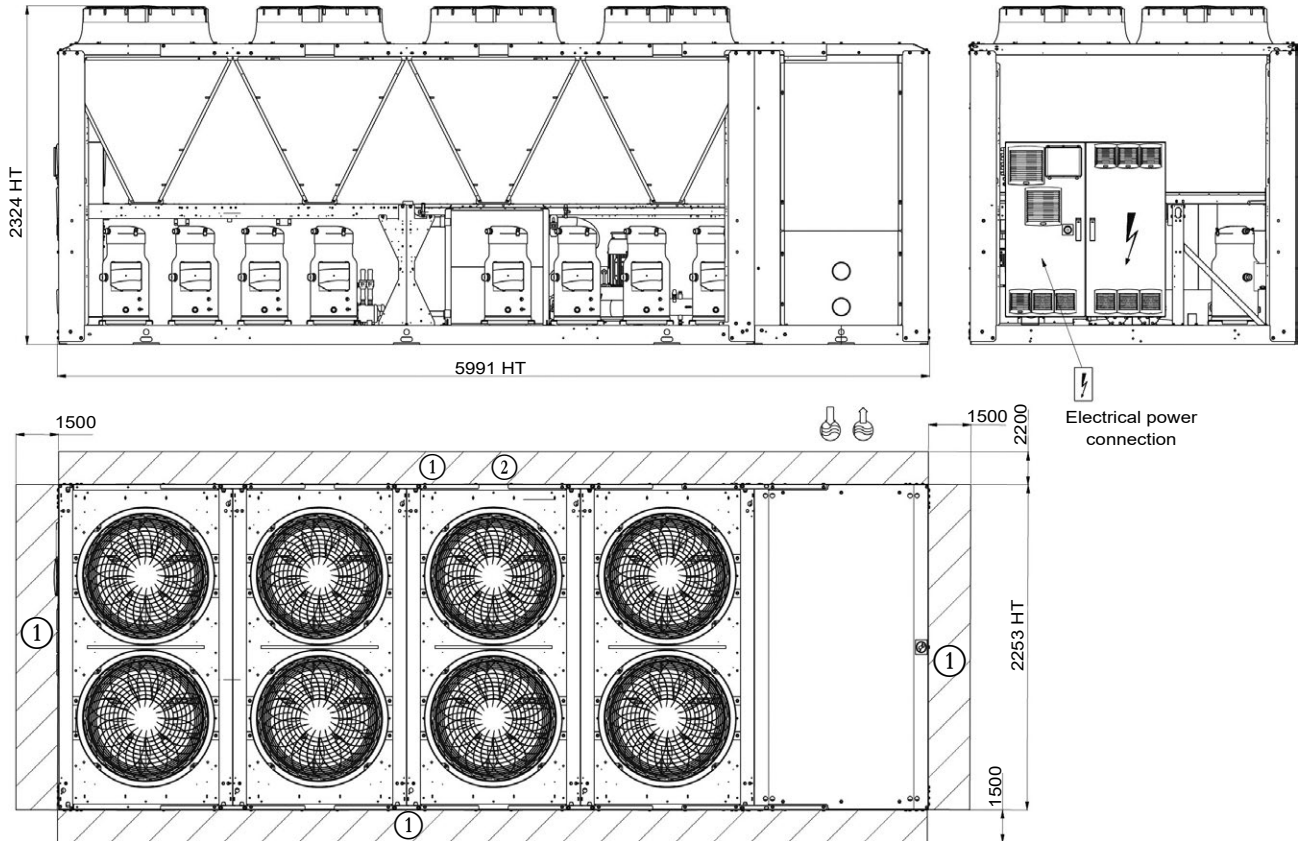

Key

All dimensions in mm

- ① Clearance required for maintenance and air flow
- ② Clearance recommended for coil removal
- Water inlet
- Water outlet
- Air outlet, do not obstruct
- Electrical cabinet

Notes:

Non-contractual drawings.

When designing a system, refer to the certified dimensional drawings provided with the unit or available on request.

Please refer to the certified dimensional drawings for the positioning of the fixing points, weight distribution points and centre of gravity coordinates.

DIMENSIONS

■ AQUACIAT^{POWER} LD 2200R to 2650R/Without buffer tank

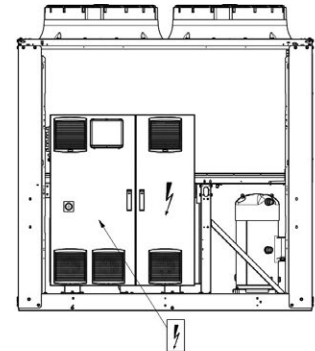
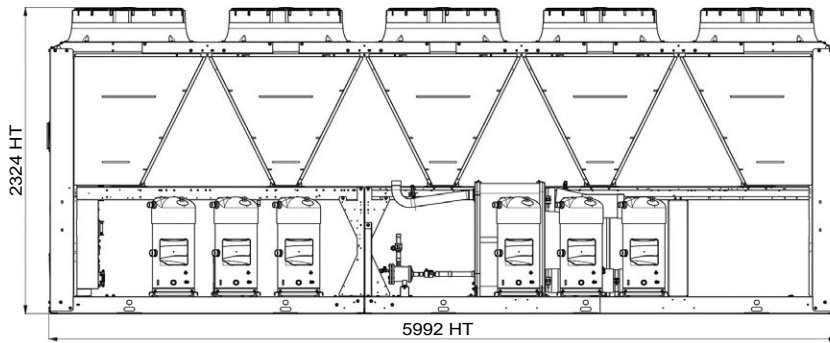

Main hydraulic connection

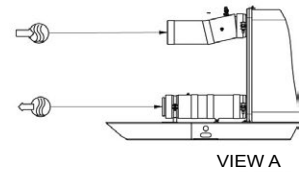
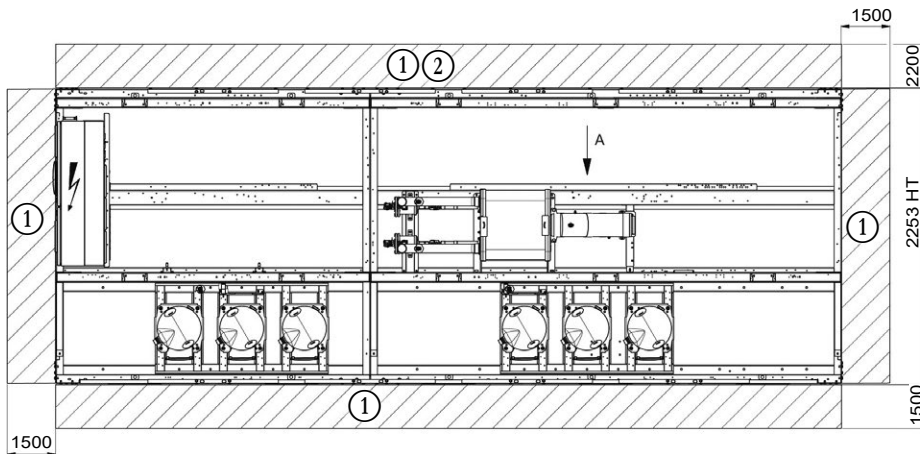

Key

All dimensions in mm

- ① Clearance required for maintenance and air flow
- ② Clearance recommended for coil removal
- Water inlet
- Water outlet
- Air outlet, do not obstruct
- Electrical cabinet

Notes:

Non-contractual drawings.

When designing a system, refer to the certified dimensional drawings provided with the unit or available on request.

Please refer to the certified dimensional drawings for the positioning of the fixing points, weight distribution points and centre of gravity coordinates.

DIMENSIONS

■ AQUACIATPOWER LD 2200R to 2650R/With buffer tank

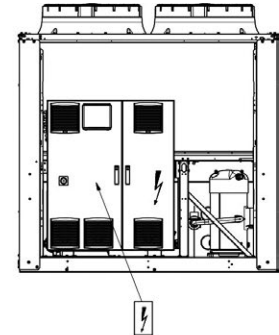
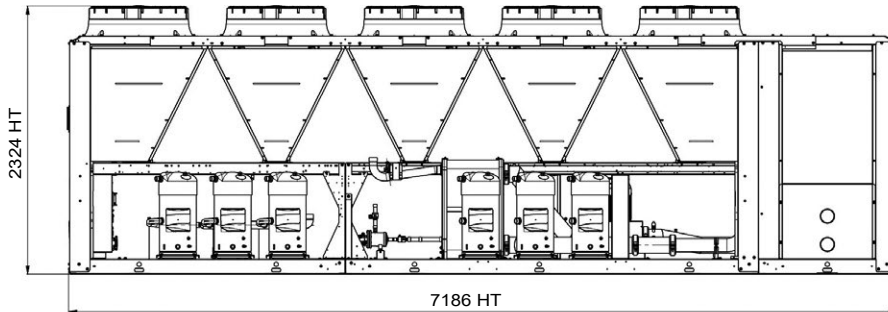

Electrical power connection

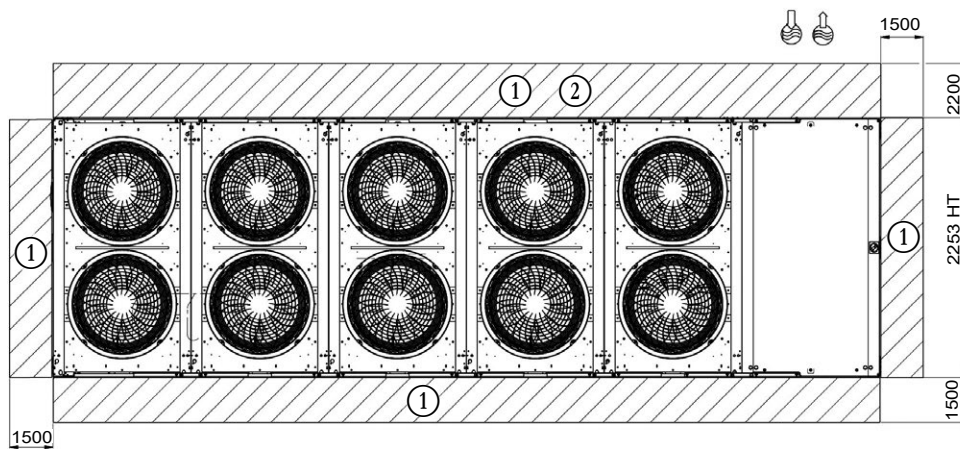

Key

All dimensions in mm

① Clearance required for maintenance and air flow

② Clearance recommended for coil removal

Water inlet

Water outlet

Air outlet, do not obstruct

Electrical cabinet

Notes:

Non-contractual drawings.

When designing a system, refer to the certified dimensional drawings provided with the unit or available on request.

Please refer to the certified dimensional drawings for the positioning of the fixing points, weight distribution points and centre of gravity coordinates.

DIMENSIONS

■ AQUACIAT^{POWER} LD 2800R to 3500R/Without buffer tank

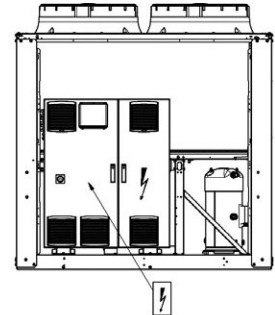
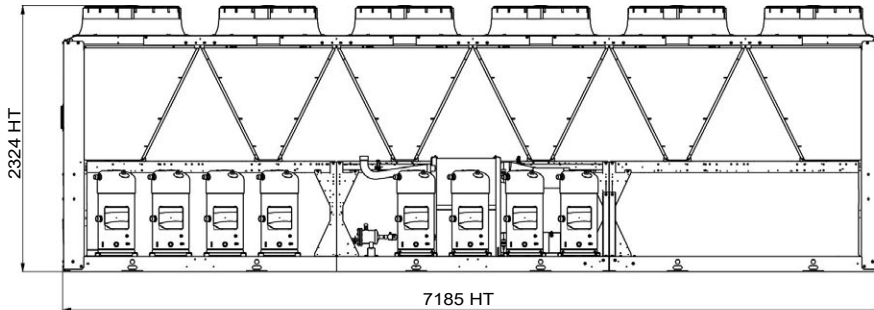

Electrical power connection

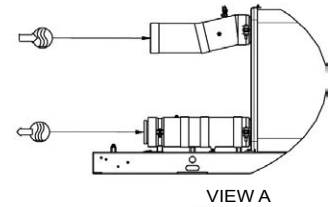
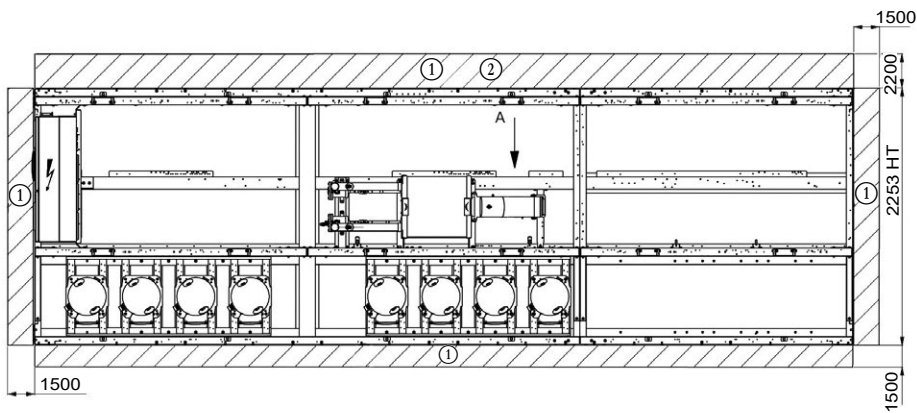

Key

All dimensions in mm

- ① Clearance required for maintenance and air flow
- ② Clearance recommended for coil removal
- Water inlet
- Water outlet
- Air outlet, do not obstruct
- Electrical cabinet

Notes:

Non-contractual drawings.

When designing a system, refer to the certified dimensional drawings provided with the unit or available on request.

Please refer to the certified dimensional drawings for the positioning of the fixing points, weight distribution points and centre of gravity coordinates.

DIMENSIONS

■ AQUACIAT^{POWER} LD 2800R to 3500R/With buffer tank

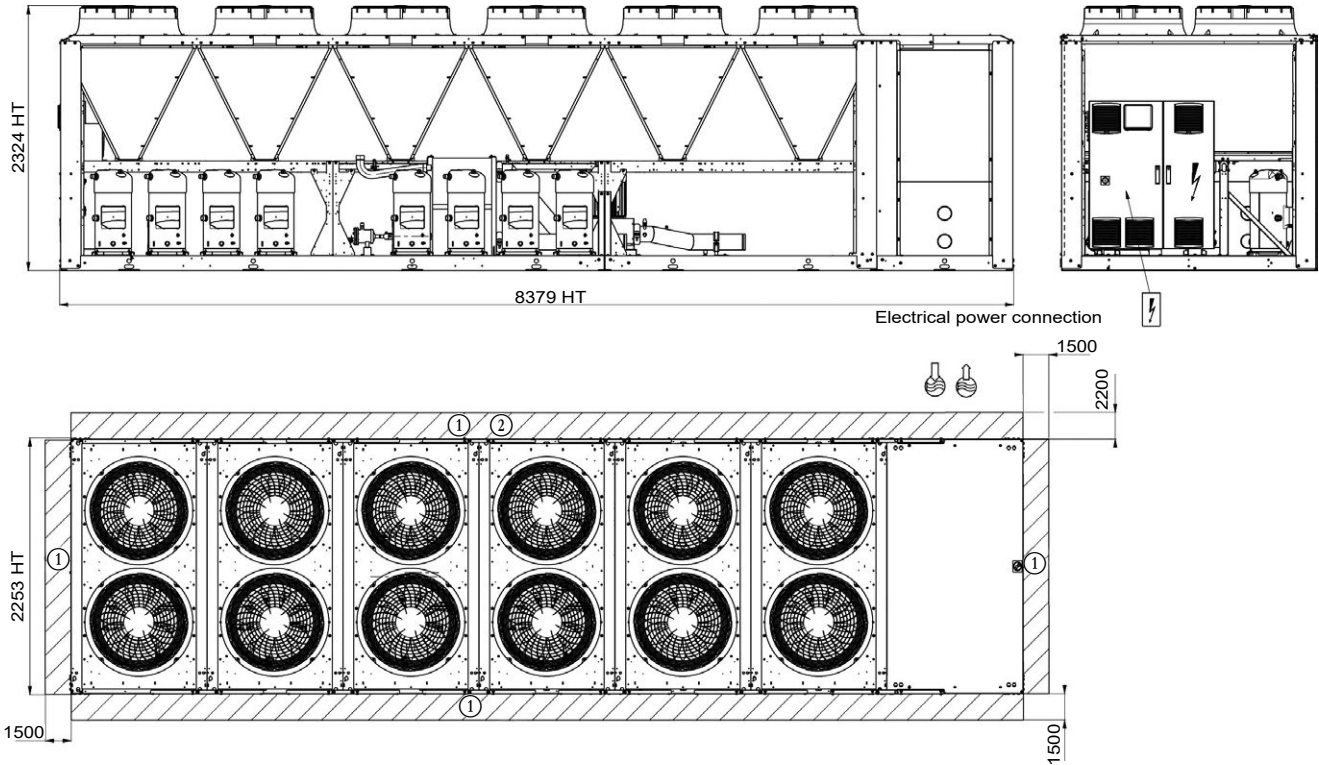

Key

All dimensions in mm

- ① Clearance required for maintenance and air flow
- ② Clearance recommended for coil removal
- Water inlet
- Water outlet
- Air outlet, do not obstruct
- Electrical cabinet

Notes:

Non-contractual drawings.

When designing a system, refer to the certified dimensional drawings provided with the unit or available on request.

Please refer to the certified dimensional drawings for the positioning of the fixing points, weight distribution points and centre of gravity coordinates.

DIMENSIONS

■ AQUACIATPOWER LD 2300R to 4000R/Without hydraulic module

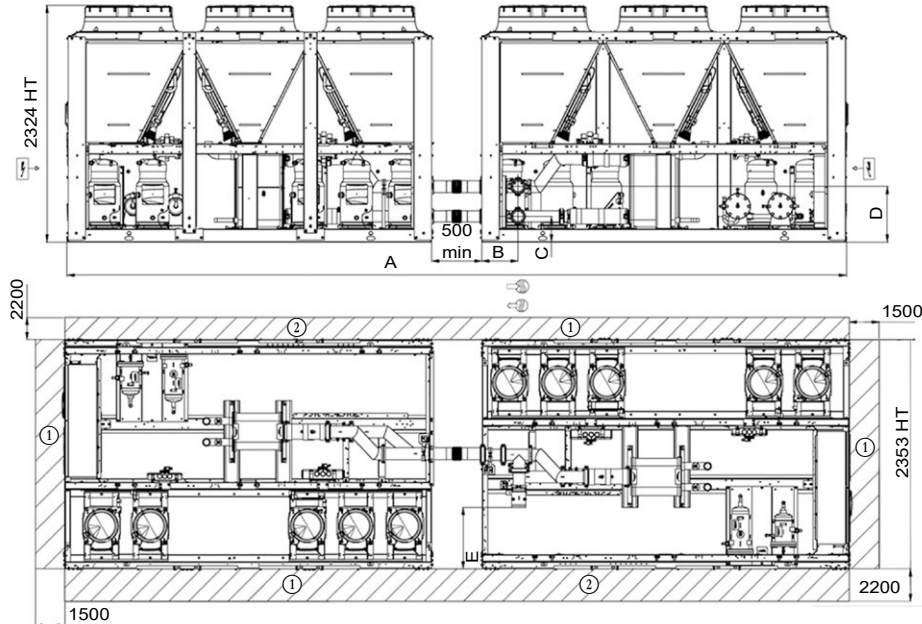

ILD	2300R to 3000R	3200R to 4000R
Length A (mm)	7680	10068
Length B (mm)	357	357
Length C (mm)	251	251
Length D (mm)	544	544
Length E (mm)	597	597
Victaulic (mm)	5"	5"

■ AQUACIATPOWER LD 2300R to 4000R/With hydraulic module

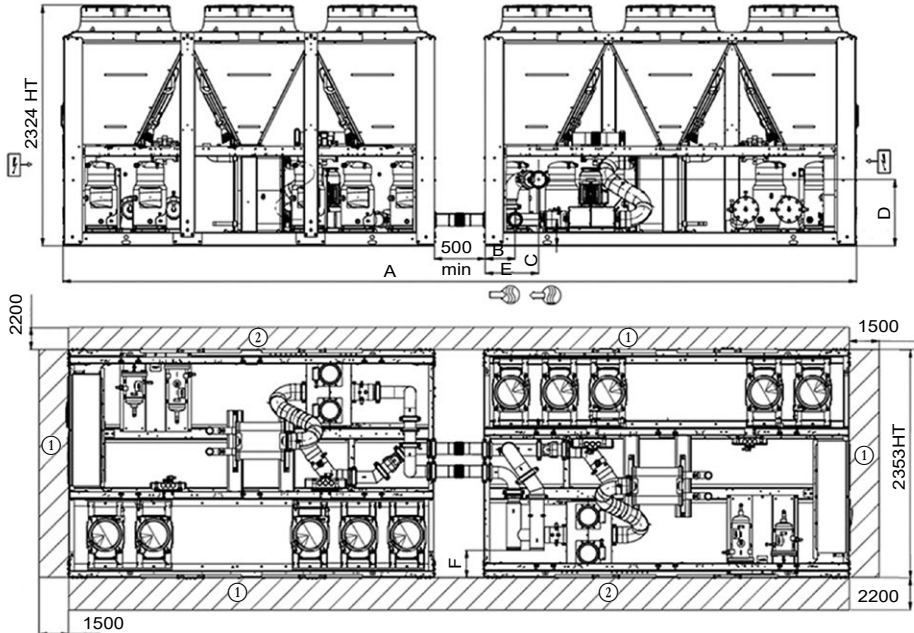

ILD	2300R to 3000R	3200R to 4000R
Length A (mm)	7680	10068
Length B (mm)	290	251
Length C (mm)	254	254
Length D (mm)	640	640
Length E (mm)	516	509
Length F (mm)	265	265
Victaulic (mm)	5"	5"

Key

All dimensions in mm

- ① Clearance required for maintenance and air flow
- ② Clearance recommended for coil removal

Water inlet

Water outlet

Air outlet, do not obstruct

Electrical cabinet

Notes:

Non-contractual drawings.

When designing a system, refer to the certified dimensional drawings provided with the unit or available on request.

Please refer to the certified dimensional drawings for the positioning of the fixing points, weight distribution points and centre of gravity coordinates.

INSTALLATION RECOMMENDATIONS

■ Water quality criteria to be respected

Warning: *It is essential that an 800-micron water filter be placed on the unit's water inlet during installation. The quality of the water used has a direct impact on the correct and compliant operation of the machine and its service life. This is particularly true if the water used clogs or corrodes components or promotes the growth of algae or micro-organisms. The water must be tested to determine whether it is suitable for the unit. It is also tested to determine whether chemical treatment is necessary and will suffice to make it of acceptable quality. This analysis should confirm whether or not the various machine components are compatible with the water they come into contact with on-site.*

WARNING: *failure to follow these instructions will result in the immediate voiding of the unit's warranty.*

■ Lifting and handling

The utmost safety precautions must be taken when lifting and handling the unit.

Always follow the lifting diagram on the unit and in the instruction manual.

Before attempting to lift the unit, make sure the path leading to its intended location is free from obstacles. Always keep the unit vertical when moving it. Never tip it or lie it on its side.

■ Choosing a location for the unit

AQUACIAT^{POWER} units are designed for outdoor installation. Precautions should be taken to protect the unit from freezing temperatures. Special attention should be paid to ensure sufficient free space (including at the top) to allow maintenance. The unit must be placed on a perfectly level, fireproof surface strong enough to support it when ready for operation. Noise pollution from auxiliary equipment such as pumps should be studied thoroughly.

Potential noise transmission routes should be studied, with assistance from an acoustical engineer if necessary, before installing the unit. It is strongly recommended that flexible couplings are placed over pipes and anti-vibration mounts are fitted underneath the unit (equipment available as an option) to reduce vibrations, and the noise this causes, as much as possible.

■ Fitting accessories supplied separately

A number of optional accessories may be delivered separately and installed on the unit on site.

You must follow the instructions in the manual.

■ Electrical connections

You must follow the instructions in the manual. All information concerning electrical connections is stated on the wiring diagrams provided with the unit. Always follow this information to the letter.

Electrical connections must be made in accordance with best current practices and applicable standards and regulations. Electrical cable connections to be made on-site:

- Electrical power supply to the unit
- Contacts available as standard enabling the machine to be controlled remotely (optional)

It should be noted that the unit's electrical system is not protected against lightning strikes.

Therefore devices to protect against transient voltage surges must be installed on the system and inside the power supply unit.

■ Pipe connections

You must follow the instructions in the manual. All pipes must be correctly aligned and slope towards the system's drain valve. Pipes must be installed to allow sufficient access to the panels for maintenance, and must be fitted with heat insulation.

Pipe fixings and brackets must be separate to avoid vibrations and ensure no pressure is placed on the unit. Water flow shut-off and control valves must be fitted when the unit is installed.

Pipe connections to be made on site:

- Water supply with pressure-reducing valve
- Evaporator, condenser and drain

Accessories essential to any hydraulic circuit must also be installed, such as:

- Water expansion tank
- Drain nozzles at pipe low points
- Exchanger shut-off valves equipped with filters
- Air vents at pipe high points
- Check the system's water capacity (install a buffer water tank if necessary)
- Flexible couplings on exchanger inlets and outlets

Warning:

- **Pressure in the hydraulic circuits below 4 bar for units equipped with the hydraulic module**
- **Place the expansion tank before the pump.**
- **Do not place any valves on the expansion tank.**
- **Make sure the water circulation pumps are placed directly at the exchanger inlets.**
- **Make sure the pressure of the water drawn in by the circulation pumps is greater than or equal to the required minimum NPSH, particularly if the hydraulic circuits are open.**
- **Test the water quality in accordance with the relevant technical specifications.**
- **Take the necessary precautions to protect the unit and hydraulic system from freezing temperatures (e.g. allow for the possibility of draining the unit). If glycol is added to prevent freezing, check its type and concentration before system start-up.**
- **Before making any final hydraulic connections, flush the pipes with clean water to remove any debris in the network.**

INSTALLATION RECOMMENDATIONS

■ System start-up

System start-up for these machines must be performed by CIAT or a CIAT-authorized firm.

You must follow the instructions in the manual.

List of system start-up checks (non-exhaustive):

- Correct positioning of unit
- Power supply protections
- Phases and direction of rotation
- Wiring connections on unit
- Direction of water flow in unit
- Cleanliness of hydraulic circuit
- Water flow rate at preset value
- Pressure in the refrigerating circuit
- Direction of rotation of compressors
- Water pressure drops and flow rates
- Operating readings

■ Maintenance operations

Specific preventive maintenance operations are required at regular intervals and should be performed by CIAT-approved contractors.

The operating parameters are read and noted on a "CHECK LIST" form to be returned to CIAT.

To do this, you must refer to and comply with the instruction manual.

You must take out a maintenance contract with a CIAT-approved refrigeration equipment specialist. Such a contract is required even during the warranty period.

CONTROL

USER-FRIENDLY INTERFACE CONSOLE

- User-friendly 4.3-inch touch screen.
- Information displayed in a choice of languages.
- Temperature and pressure readings.
- Operating and fault status diagnostics.
- Master/slave control of two machines in parallel.
- Fault memory management.
- Pump management.
- Time schedule.
- IP web server
- Programmable maintenance
- Preventive maintenance
- F-Gas maintenance
- E-mail alert
- Indication of energy supplied and consumed instantly (kW) and integrally (kWh)



ABOUND HVAC Performance REMOTE MACHINE SUPERVISION

2 years of services with:

- Monitoring of machine operation (operation overviews and curves, alarm logs).
- E-mail alerts for alarms (optional SMS alerts).
- Remote updates for ABOUND HVAC Performance.
- Access to a log of machine operation data.
- Remote advice on using ABOUND HVAC Performance.
- System start-up and operating readings.

ABOUND



PRODUCT FUNCTIONALITY

POTENTIAL-FREE (DRY) CONTACTS AVAILABLE AS STANDARD

Inputs:

- Automatic operation control
- Heating/cooling mode selection
- Selection of setpoints 1 / 2
- Power limitation.

Outputs:

- General fault reporting
- Operational status reporting

Additional inputs available as options:

- Setpoint adjustment by 4-20 mA signal
- Power limitation adjustable by 4-20 mA signal
- Second power limitation level
- End of storage signal
- User fault display
- Contact for refrigerant leak detector

Additional outputs available as options:

- Indication of the power level by 0-10 V signal
- Minor alert reporting
- Unit shut-down general fault reporting
- Desuperheater pump On/Off control
- On/off control for a boiler
- 4-stage on/off management for additional heaters

AVAILABLE OUTPUTS

- MODBUS-JBUS RTU (RS485) or TC/IP (standard) open protocol
- LONWORKS protocol (option)
- BTL certified BACNET IP protocol (option)

CIAT SYSTEM FUNCTIONALITY

Communication to the CIAT Energy pool controlled by TruVu Plan Sequencer (4 units) or PowerCTRL (8 units).

These CIAT plan managers include:

- Energy optimisation of refrigeration and heating using several generators,
- Manages free cooling capacity
- Uses heat recovery to supply
- Domestic hot water.
- PowerCTRL is fully customisable in order to meet the user's needs and the specific features of the water loop.

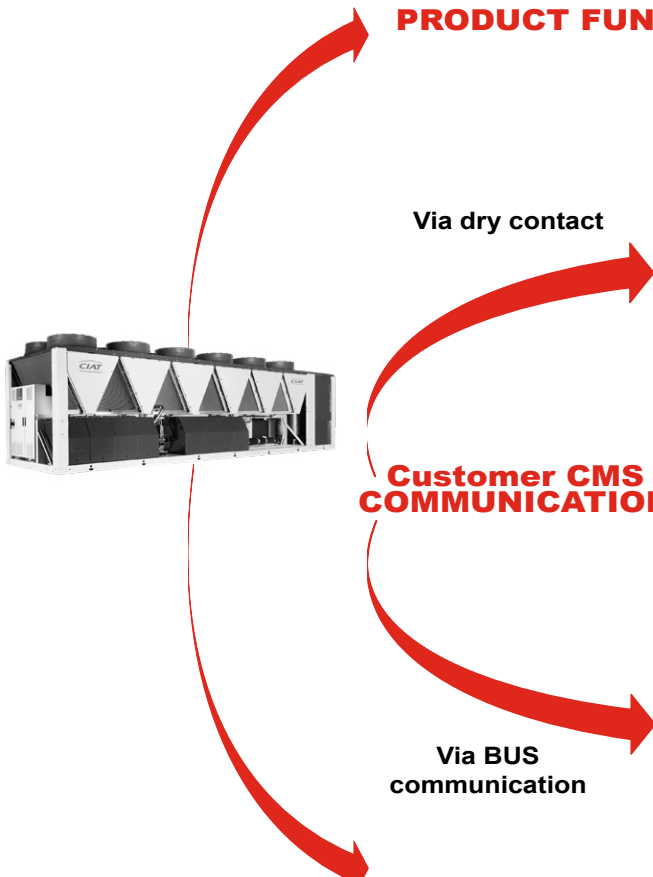

The quality management system of this product's assembly site has been certified in accordance with the requirements of the ISO 9001 standard (latest current version) after an assessment conducted by an authorized independent third party.

The environmental management system of this product's assembly site has been certified in accordance with the requirements of the ISO 14001 standard (latest current version) after an assessment conducted by an authorized independent third party.

The occupational health and safety management system of this product's assembly site has been certified in accordance with the requirements of the ISO 45001 standard (latest current version) after an assessment conducted by an authorized independent third party.

Please contact your sales representative for more information.

Order No.: NA23.769C, 12.2023 - Supersedes No.: NA23.769B, 07.2023.

Carrier, Montluel, France.

The manufacturer reserves the right to change the product specifications without notice.

The illustrations in this document are for information only and not part of any offer for sale or contract.

The manufacturer reserves the right to change the design at any time without notice.